

ATEQ D520
Version 1.32



www.ateq.com

REVISION OF THE D520 USER MANUAL

Due to continuing improvements, the information contained in this user manual, the features and design of this device are subject to be changed without prior notice.

<u>Edition/ Revision</u>	<u>Reference</u>	<u>Date</u> (week/year)	<u>Chapters updated</u>
First edition	UM-22100A-U	22/2003	-----
Second edition	UM-22100B-U	10/2004	All chapters. Evolution of the programme from the 1.00 to 1.10 version. Integration of two capillaries. Addition of the "Single CAL" and "No negative" functions, version "High precision".
Third edition	UM-22100C-U	41/2004	Evolution of the program version from the 1.10 to the 1.20. Add "High precision" function, electronic regulator instruction recover function and pressure filtering.
Fourth edition	UM-22100D-U	08/2005	Evolution to the 1.21 version: gas version (option).
Fifth edition	UM-22100E-U	38/2009	Evolutions to the 1.32 version, add the "Sequence" function, add bar code option and add flow regulation function.
Sixth edition	UM-22100F-U	47/2009	Preamble: add 1 l/h and 80 l/h capillary, correction of the principle scheme for the indirect measurement (recovery).
Seventh edition	UM-22100H-U	02/2012	Chapter 4: modification of the sequences management and up dating the bar code function. H indices to be the same as the French version.

Recommendations for leak testing instruments

Precautions for the test environment

- Keep the test area as clean as possible.

Precautions for the operators

- **ATEQ** recommends that the operators using the instruments should have a suitable qualification and training with respect to the work bench requirements.

General precautions

- Read the user manual before using the instrument,
- all electrical connections to the instrument must be equipped with a safety system (fuse, circuit breaker...) appropriate to its needs and complying with the standards,
- to avoid electromagnetic interference, the cable connections to the instrument should be less than two meters in length,
- it is essential that the electrical main is earthed,
- disconnect the electrical connections to the equipment before maintenance,
- cut the air supply for any kinds of operation on the pneumatic assembly,
- do not open the instrument when it is powered up,
- avoid water spillage near of the instrument,
- **ATEQ** is at your disposal for any further information concerning the use of the instrument under maximum safety conditions.



We would like to bring to your attention that ATEQ will not be held responsible for any accident connected to the improper use of the instrument, to the work bench or to the lack of compliance with safety rules.

ATEQ Company is free from any responsibility for any adjustment of its instrument which would not have been done by its own technicians.

The ATEQ cannot be held responsible if the instrument (program, mechanics or electronics) has been modified without prior written consent.

ATEQ, THE ASSURANCE OF A COMPETENT AFTER SALES SERVICE

■ THE ATEQ AFTER SALES SERVICE IS :

- a team of qualified technicians,
- a permanent telephone assistance,
- agencies close to you for faster reaction,
- a stock of spare parts available immediately,
- a car fleet for rapid intervention,
- a commitment to quality ...

■ THE OVERHAUL

ATEQ carries out the overhaul of your instruments at interesting prices.

The overhaul corresponds to the maintenance of the instrument (checking, cleaning, replacing of used parts) as part of preventive maintenance.

Preventive maintenance is the best way to guarantee reliability and efficiency. It allows the maintenance of a group of instruments in good operational order and prevent eventual break-downs.

■ MAINTENANCE KITS

The ATEQ After Sales Service proposes, two kits destined for the preventive maintenance of the pneumatic circuits of instruments.

■ CALIBRATION

This may be carried out on site or in our offices.

ATEQ is attached to the COFRAC and delivers a certificate following a calibration.

■ TRAINING COURSES

In the framework of partnership with our customers, ATEQ offers two types of training in order to optimise the usage and knowledge of our instruments. They are aimed at different levels of technician:

- method / control training,
- maintenance / upkeep training.

■ A TARGETED TECHNICAL DOCUMENTATION

A number of technical documents are at your disposal to allow you to intervene rapidly in the event minor breakdowns:

- problem sheets describing and offering solutions to the main pneumatic and electronic problems,
- several maintenance manuals.

■ A QUALITY GUARANTEE

The instruments are guaranteed for parts and labour in our offices:

- 2 years for leak detection equipment,
- 1 year for electrical tests to norms instruments,
- 1 year for the accessories.

Our After Sales Service is capable of rapidly answering all your needs and queries.

We strongly recommend to send the instrument back to ATEQ once a year for re-calibration

PREFACE

Dear Customer,

You have just purchased an **ATEQ** instrument, we thank you for the trust you have placed on our brand. This instrument has been designed to ensure a long and unparalleled life expectancy, and we are convinced that it will give you complete satisfaction during many long years of operation.

In order to maximise the life expectancy and reliability of your **ATEQ** instrument, we recommend that you install this instrument on a secured workbench and advise you to consult this manual in order to familiarise yourself with the functions and capabilities of the instrument.

Our **ATEQ** After Sales Service centre can give you recommendations based on your specific operation requirements.

ATEQ

TABLE OF CONTENTS

PREAMBLE	5
1. DEFINITION OF THE ATEQ D520	5
2. CHARACTERISTICS OF THE MEASUREMENT	6
2.1. Pressure drop measurement.....	6
2.2. Test pressure measurement	6
2.3. Mechanical pressure regulation	6
3. THE DIFFERENT MEASUREMENT PRINCIPLES	7
3.1. Direct measurement.....	7
3.2. Indirect measurement (or recovery mode).....	8
4. PRESSURE, TEMPERATURE & VISCOSITY EFFECT ON THE MEASUREMENT	9
4.1. Pressure variation	9
4.2. Viscosity and temperature variation	9
5. CALIBRATION.....	10
5.1. Factory calibration	10
5.2. Manual calibration	10
6. PRINCIPLE OF A CYCLE	11
7. PRESENTATION OF THE SYMBOLS	12
Chapter 1	INSTALLATION OF THE INSTRUMENT
1. PRESENTATION OF THE ATEQ D520	15
2. INSTALLATION OF THE INSTRUMENT	16
2.1. Presentation of the connectors on the case of the D520	16
2.2. Connector details	17
Chapter 2	USER INTERFACES
1. PRESENTATION OF THE FRONT PANEL OF THE D520	27
2. PRESENTATION OF THE KEYBOARD KEYS	28
2.1. Navigation keys.....	28
2.2. Cycle keys	29
3. KEY LOCK.....	29
4. REGULATOR.....	30
5. INFRA-RED INTERFACE	30
6. 4 LINE LCD DISPLAY	30
7. QUICK CONNECTOR.....	30
8. FUNCTIONNALITY OF THE INDICATORS	31
Chapter 3	STARTUP AND ADJUSTMENTS
1. POWERING UP THE ATEQ D520	33
2. CREATION OF A TEST PROGRAM.....	34
2.1. Choice of the program number	34
2.2. Selection of the test type.....	35
2.3. Adjustment of the parameters	36
3. COPYING A TEST PROGRAM	40
4. DELETING A PROGRAM OR THE NAME OF A PROGRAM.....	42
5. LAUNCHING OF A CYCLE	43
5.1. Choice of the program number to be launched.....	43
5.2. Setting the test pressure	44
6. STARTING A MEASUREMENT CYCLE.....	45
7. STOPPING A CYCLE	45

Chapter 4	FUNCTIONS OF THE INSTRUMENT
1. MENU STRUCTURE.....	47
1.1. Main menu.....	47
1.2. "FUNCTIONS" menu when activated.....	52
2. CONFIGURATION MENU	55
2.1. Extended menus	55
2.2. Automatic save.....	72
2.3. Program sequences	73
2.4. Ready status	76
2.5. Reference cal	76
2.6. Bar Graph.....	76
2.7. Hour.....	77
2.8. Regulator learning	77
2.9. RS232	78
2.10. RS485	81
2.11. Modbus.....	81
2.12. Security	81
2.13. Lighting the screen.....	82
2.14. Bar code option	83
2.15. I/O configuration.....	86
2.16. Remote control.....	87
3. SPECIAL CYCLES MENU.....	88
3.1. Special cycles available	88
3.2. Regulator.....	89
3.3. Calculation of the automatic thresholds	90
3.4. Infinite fill	91
3.5. Piezo reset (auto zero).....	92
3.6. Manual calibration	93
3.7. ATR learning	96
4. SERVICE MENU	97
4.1. Servicing of the parameters	97
4.2. Servicing of the sensors.....	98
5. RESULTS MENU	99
6. LANGUAGE MENU	99
7. STAND-BY MENU	99
7.1. Standby using the menu	100

Chapter 5	ACCESSORIES
1. ACCESSORIES SUPPLIED WITH THE INSTRUMENT	101
1.1. Power supply.....	101
2. OPTIONAL ACCESSORIES.....	102
2.1. Flow master leaks	102
2.2. Needle valve and leak flow calibrator	103
2.3. Automatic connectors with expandable joints	104
2.4. Filtration kit.....	104
2.5. Remote controls	105
2.6. Remote front panel RC5	106
2.7. Intelligent remote control.....	108
2.8. External cutting valve	110

Chapter 6	ERROR MESSAGES
ERROR MESSAGES	111

Chapter 7	OPERATIONAL PROBLEMS
1. PHENOMENON NOTED.....	113
1.1. Condition of the machine's seals	113
1.2. Damaged instrument seals	113
1.3. Bumper pad.....	113
1.4. Pneumatic Link.....	113
1.5. Environment	114
1.6. Calibration	114
1.7. Concerns about reliability of the instrument's circuits	114
Appendices	ATEQ D520
1. TECHNICAL CHARACTERISTICS OF THE D520	115
2. DIMENSIONS OF THE D520.....	116
3. CONVERSION TABLE	117
4. PARAMETERS SAVED	118
5. VALVE CODES USED IN YOUR APPLICATION	119
6. PERSONAL NOTES	120
Index	121

PREAMBLE

1. DEFINITION OF THE ATEQ D520

The **ATEQ D520** is a flow meter which measures a drop in pressure with a differential sensor (transducer) which is placed at the extremities of a calibrated flow tube.

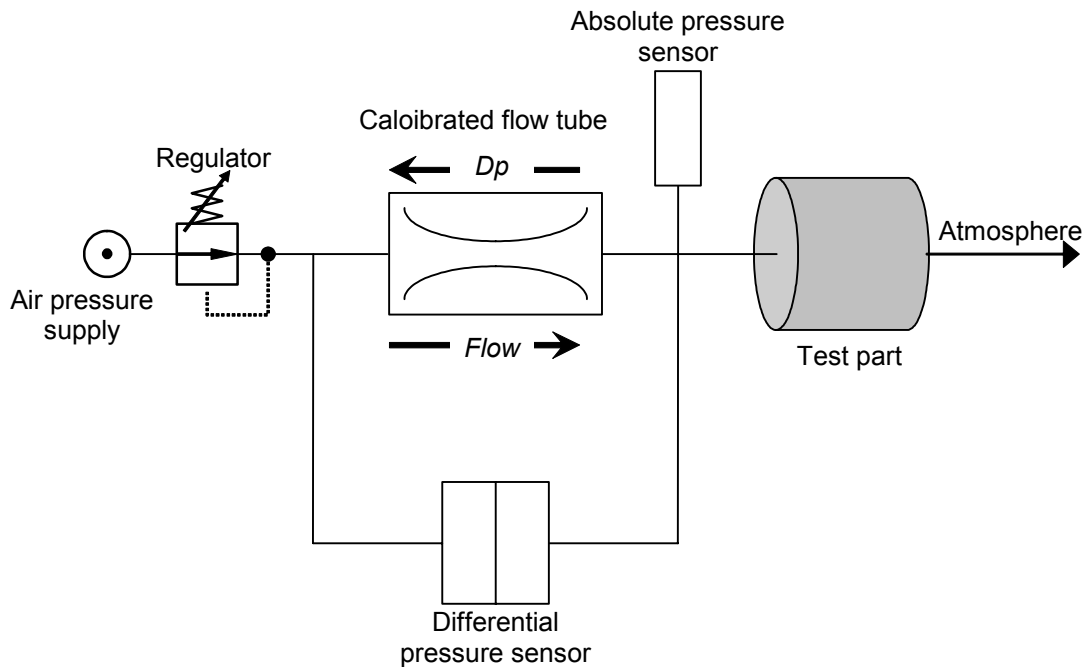

When fluid (gas) moves through a calibrated flow tube (laminar flow), a drop in pressure occurs, the value of which is proportional to flow.

$$\Delta P = 8\mu LQ/\pi R^4$$

μ : viscosity of the fluid

L: length of the calibrated flow tube

R: radius of the calibrated flow tube

Q: flow

ΔP : drop in pressure in the calibrated flow tube

2. CHARACTERISTICS OF THE MEASUREMENT

2.1. PRESSURE DROP MEASUREMENT

RANGE L/H	ACCURACY	MAXIMUM RESOLUTION L/H
1	+/- (2,5% of the flow + 0,001 l/h)	0,001
5	+/- (2,5% of the flow + 0,005 l/h)	0,001
30	+/- (2,5% of the flow + 0,03 l/h)	0,01
80	+/- (2,5% of the flow + 0,08 l/h)	0,01
150	+/- (2,5% of the flow + 0,150 l/h)	0,1
500	+/- (2,5% of the flow + 0,5 l/h)	0,1
1500	+/- (2,5% of the flow + 1,5 l/h)	1
4000	+/- (2,5% of the flow + 4 l/h)	1
10000	+/- (2,5% of the flow + 10 l/h)	1

(20° / 1013 mbar)

2.2. TEST PRESSURE MEASUREMENT

RANGE	ACCURACY	MAXIMUM RESOLUTION
PE = 7.5 kPa (PE < 75 mbar)	+/- (1,5% of the pressure + 0,2 hPa)	0,1 % PE
PE < 30 kPa (PE < 0,3 bar)	+/- (1,5% of the pressure + 1 hPa)	
30 kPa ≤ PE ≤ 100 kPa (0,3 bar ≤ PE ≤ 1 bar)	+/- (1,5% of the pressure + 3 hPa)	
100 kPa < PE ≤ 500 kPa (1 bar < PE ≤ 5 bar)	+/- (1,5% of the pressure + 7.5 hPa)	

2.3. MECHANICAL PRESSURE REGULATION

- 600 kPa to -10 kPa / 800 Pa to 6 kPa / 500 Pa to 14 kPa / 6 kPa to 100 kPa / 5 kPa to 210 kPa / 10 kPa to 350 kPa.

3. THE DIFFERENT MEASUREMENT PRINCIPLES

There exists two measurement principles, they are: direct measurement and the indirect measurement (also known as with recovery or under bell).

The instrument can work in depressurisation (optional) both in direct and indirect measurement.

3.1. DIRECT MEASUREMENT

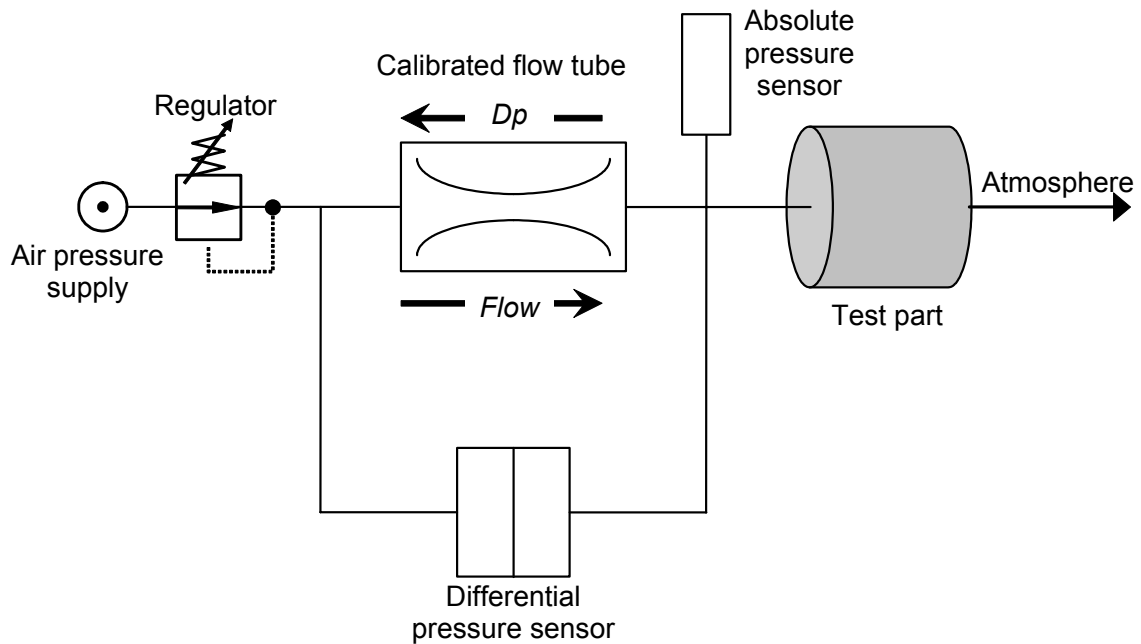

As shown in the diagram above the test pressure is applied directly to the test part input after having flowed through the calibrated flow tube.

Once the test part is filled, the ATEQ D520 measures the drop in pressure at the extremities of the calibrated flow tube with a differential sensor.

3.2. INDIRECT MEASUREMENT (OR RECOVERY MODE)

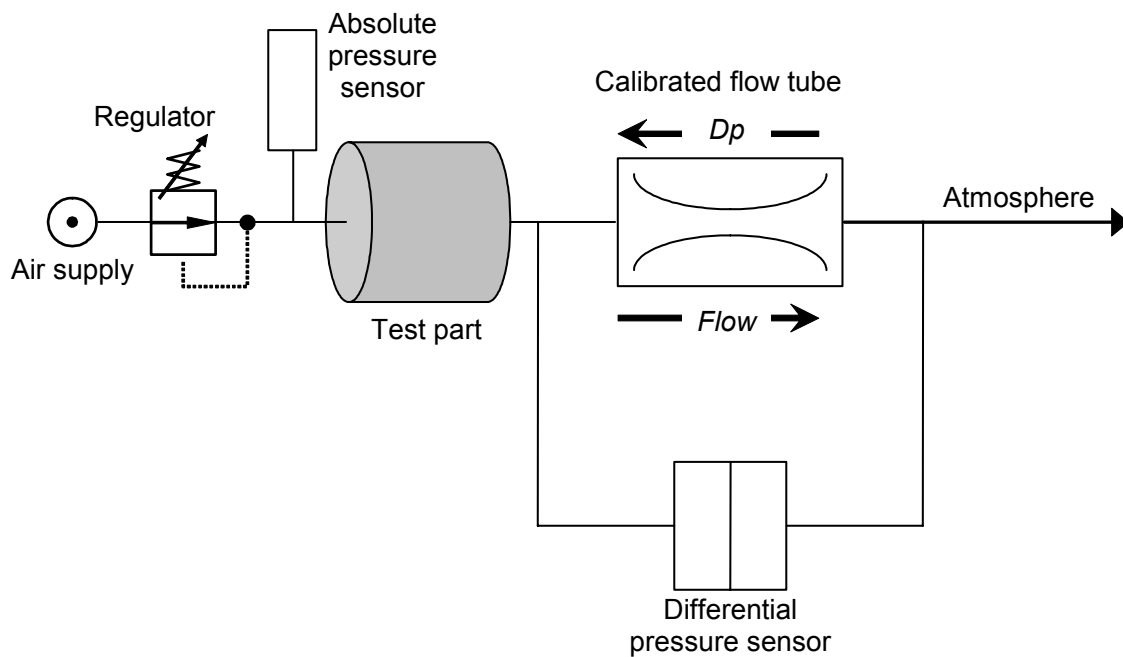

The calibrated flow tube is placed following the output of the test part. The output of the calibrated flow tube is to the atmosphere.

Depending on the part type, it may be possible to use a bell (ex: shower head where it is impossible to recover the flow other than through the use of a bell). This method can only be used if the recovery of the flow is easy.

The indirect measurement allows a considerable gain in time as the flow which arrives in the calibrated flow tube is already stabilised.

4. PRESSURE, TEMPERATURE & VISCOSITY EFFECT ON THE MEASUREMENT

4.1. PRESSURE VARIATION

As shown in the direct measurement diagram, the test part is in series in the test circuit, the test pressure set by the regulator is not entirely restored at the input of the test part due to pressure losses caused by the calibrated flow tube. Additionally the output pressure of the regulator changes depending on the flows.

The results are always expressed as a function of the test pressure. That is why a silicium sensor constantly monitors the real test pressure applied to the part. Depending on the pressure value read the **ATEQ D520** applies a correction factor which allows a constant compensation for the pressure drops in the test circuit.

Note that the further the test part is from the cell, the higher the pressure drop is. This should be avoided (possibility of pressure measurement on the part).

4.2. VISCOSITY AND TEMPERATURE VARIATION

The viscosity of a gas is directly linked to its temperature. The higher the temperature is, the greater the viscosity. The law of "Poiseuille" shows that when the viscosity increases, the pressure drop increases.

These two parameters, temperature and viscosity have an influence on the accuracy of the measurement. A correction is applied depending on the real temperature of the gas flowing through the system.

Variations in the temperature of the parts during the test and in relation to each other should be avoided by the "High precision" mode (optional):

An automatic acquisition cycle on a known master value is realised before each test cycle, it allows calculating the test part value with the current atmospheric conditions.

5. CALIBRATION

There exist 2 different types of calibration.

5.1. FACTORY CALIBRATION

The factory calibration is set in the instrument.

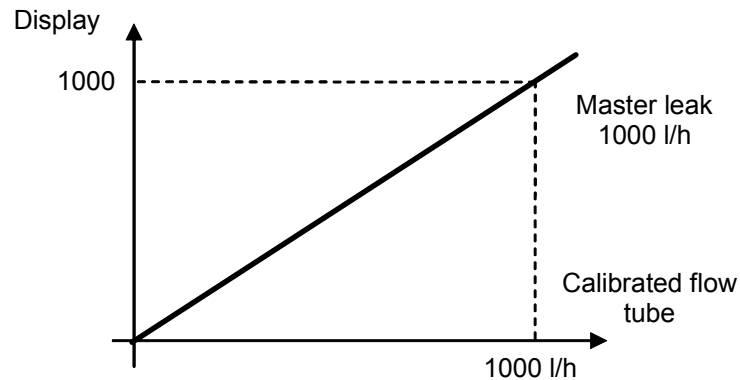

Note: this calibration does not take into account tube lengths, seal jig restrictions, ...

5.2. MANUAL CALIBRATION

It is possible that the unit the instrument is delivered in or some external elements (seals, pipes...) result in the factory calibration being unsatisfactory.

In this case a manual calibration taking into account the previously stated elements, can be carried out by the operator. For this calibration, the calibrated master leak should be used in the same conditions as the parts to be measured (diameter, length of the pipes).

6. PRINCIPLE OF A CYCLE

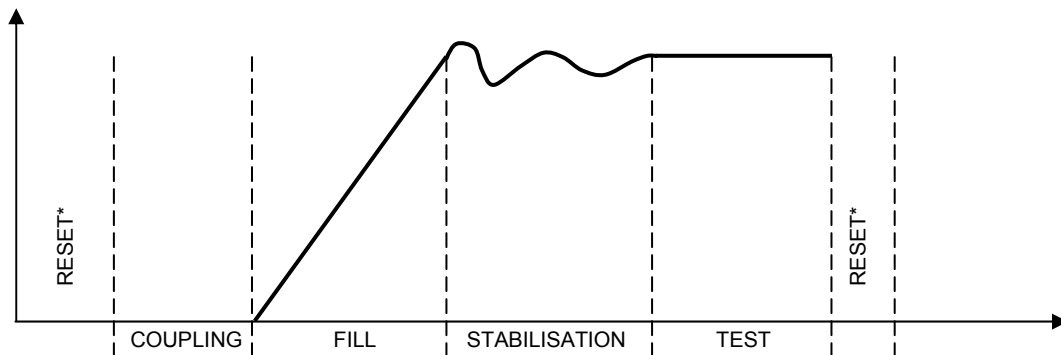





The measurement cycle is made of 4 phases:

	1	2	3	4	5	1'	
Start	(Reset)*	Coupling	Fill	Stabilisation	Test	(Reset)*	Cycle end

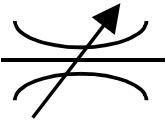
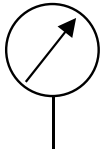
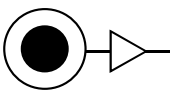
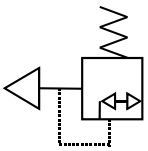
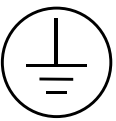
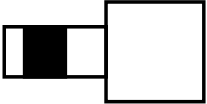
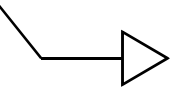
Start	Start of the cycle.
(Reset)*	Reset of the pressure sensor to correct the eventual drifts, this phase can be placed at the start or at the end of a cycle depending on the requirement of the operator. Parameter to be set.
The coupling time	Time during which the sealing jig of the parts is put in place before the part is filled. The instrument can be fitted with the automatic connector option (this option adds a valve). This valve which is piloted throughout the cycle time allows a control of the jig setup.
The fill time	This is the time during which the part is pressurised until the compensation flow is obtained.
The stabilisation time	This is the time during which the flow value stabilises.
The test time	The differential pressure sensor measures the pressure difference on the extremities of the calibrated flow tube. The signal is treated by the electronics which display the result and indicate whether a part is good or bad.
(Reset)*	Pressure sensor reset to correct eventual drifts. This phase can be placed at the start of the cycle or at the end of the cycle depending on the requirement of the operator. Parameter to be set.
End of Cycle	The instrument stops the measurement and sends an end of cycle signal.

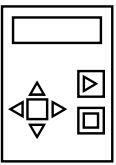
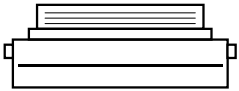
7. PRESENTATION OF THE SYMBOLS

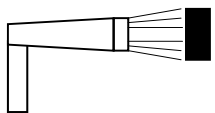
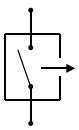
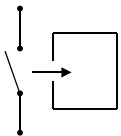
Symbol	Name	Function
	Adjust leak connector	Pneumatic connector for the plugging of a calibrated leak (ruby kind) or an adjustable leak.
	Pressure connector	Pneumatic connector for the plugging of a manometer for an external checking of the pressure.
	Pressure supply	of the air supply from the 6 bar network.
	Test circuit supply	Pneumatic connector (according to option) for the plugging of a supplementary pneumatic supply, used in case of test pressure greater than 8 bar.
	Ground connector	Connector for the electric plugging to the ground.
	Automatic connector	Pneumatic connector for the driving of an external logic or pneumatic components (pneumatic sealing connector).
	Connector	Connector for pneumatic output.
	Connector	Connector for pneumatic input.
	Warning!	Read and respect the instructions of the user manual, before plugging and using the instrument.
	Remote control	Connector for a remote control.
	Printer	Connector for printer plugging.

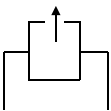
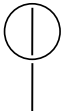
Symbol	Name	Function
	Bar code reader	Connector for bar code reader plugging.
	Output	Dry contact output.
	Input	Dry contact input.
	Infrared link	Infrared link, at this place there's the receiver and transmitter of the infrared link.
	Analogue output	Analogue output.
	Analogue input	Analogue input for the temperature sensor.

Chapter 1

INSTALLATION OF THE INSTRUMENT

1. PRESENTATION OF THE ATEQ D520

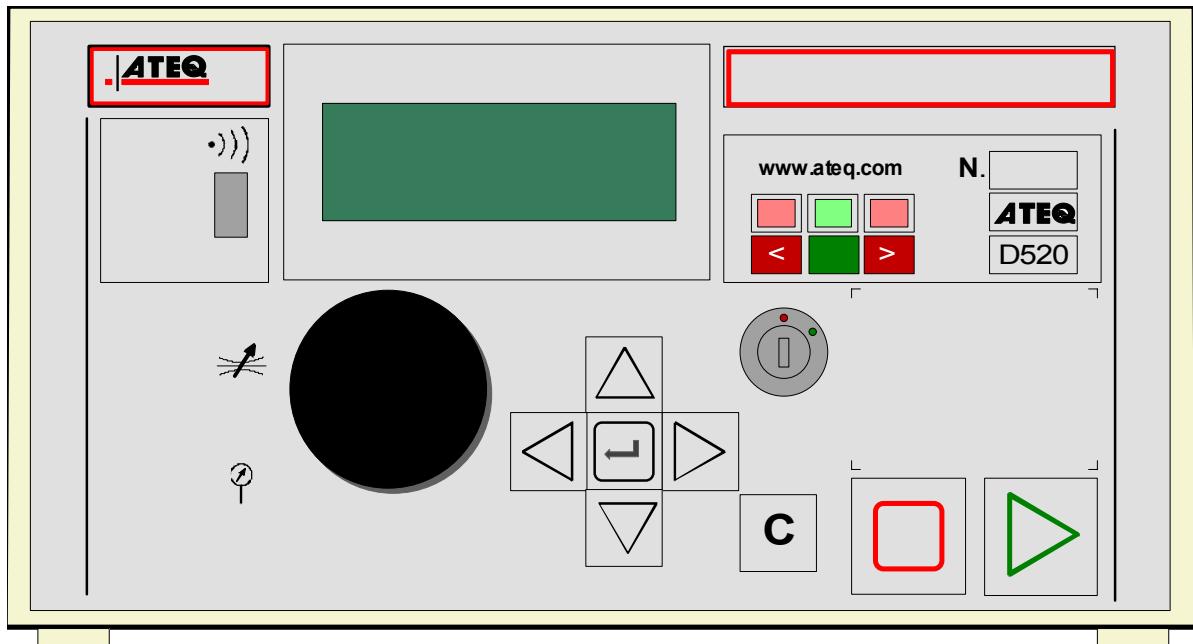

The **ATEQ D520** is presented in a painted and formed metal case which rests on four rubber feet. The upper cover is linked to the structure with 2 screws.

The format of the case has been reduced to allow easy insertion of the instrument.

The instrument is delivered with an external 24 V DC power supply.

2. INSTALLATION OF THE INSTRUMENT

2.1. PRESENTATION OF THE CONNECTORS ON THE CASE OF THE D520

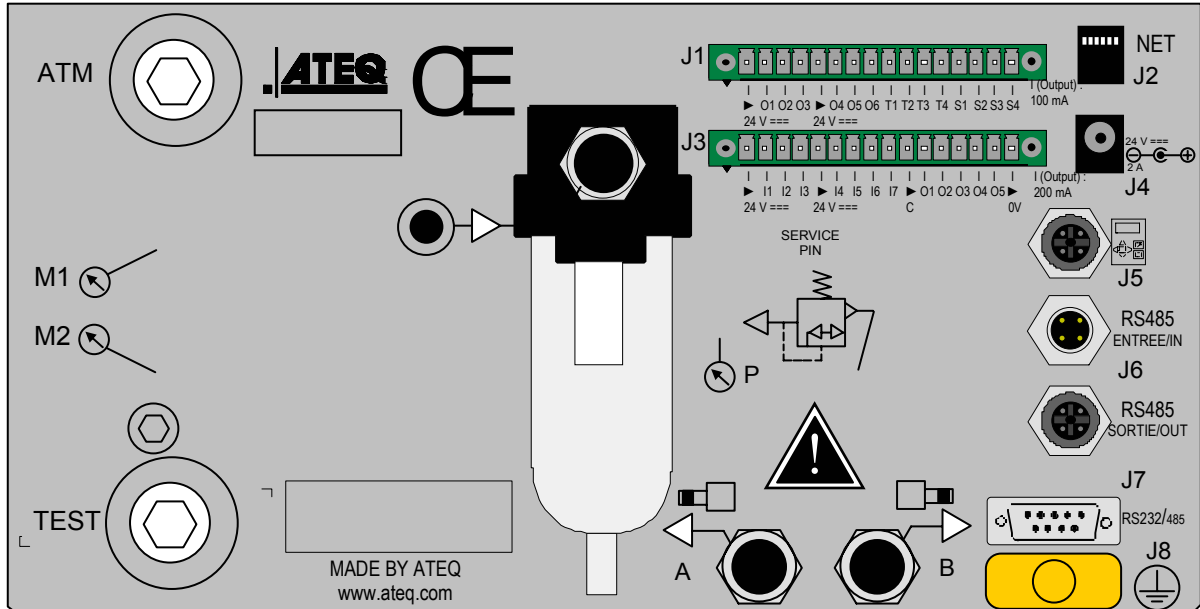

2.2. CONNECTOR DETAILS

2.2.1. Electrical connectors

The **ATEQ D520** operates under a power of 24V DC with either :

- ✓ the transformer delivered with the instrument,
- ✓ or through the network cable when the instrument is a slave.

2.2.1. 1) J1 connector (Output codes / Analogue outputs / Temperature sensors)

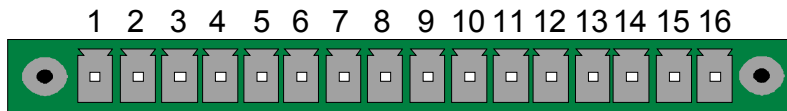

Pin 1	COMMON (outputs 1, 2, 3) + 24 V DC	OUTPUT CODES 24V DC 100mA Max outputs
Pin 2	Output n°1, open collector	
Pin 3	Output n°2, open collector	
Pin 4	Output n°3, open collector	
Pin 5	COMMON (outputs 4, 5, 6) + 24 V DC	
Pin 6	Output n°4, open collector	
Pin 7	Output n°5, open collector	TEMPERATURE SENSOR
Pin 8	Output n°6, open collector	
Pin 9	12V DC Sensor power supply (2 mA max)	
Pin 10	0V Sensor power supply	ANALOGUE OUTPUTS
Pin 11	Sensor input n°1	
Pin 12	Sensor input n°2	
Pin 13	Analogue output n°1	
Pin 14	COMMUN (analogue output 1)	
Pin 15	Analogue output n°2	
Pin 16	COMMUN (analogue output 2)	

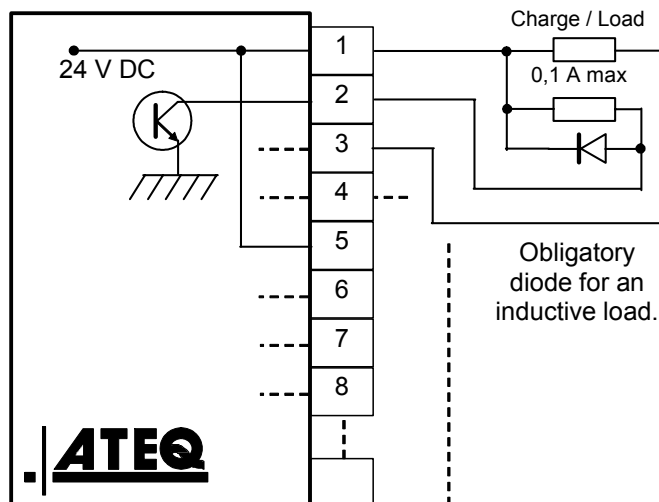

2.2.1. 2) J2 connector

Telephone network socket. Not used.



2.2.1. 3) J3 connector (Inputs/Outputs All or Nothing)

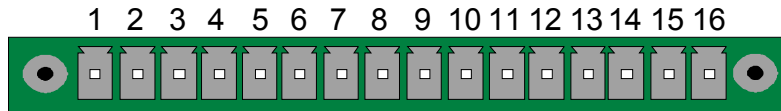

Pin 1	RESET input (input 1)	INPUTS (Activation by 24 V DC)
Pin 2	Common (+ 24 V)	
Pin 3	START input (input 2)	
Pin 4	Common (+ 24 V)	
Pin 5	Input 3 (program selection)	
Pin 6	Input 4 (program selection)	
Pin 7	Input 5 (program selection)	
Pin 8	Input 6 (program selection)	
Pin 9	Input 7 (programmable input)	
Pin 10	Common floating outputs	DRY CONTACT OUTPUTS 60V AC / DC Max 200mA Max
Pin 11	Good part output	
Pin 12	High bad part output	
Pin 13	Low bad part output	
Pin 14	Warning output	
Pin 15	End of cycle output	
Pin 16	0 V	

2.2.1. 4) Activation of a program on the J3 connector inputs

To activate a program on the J3 connector inputs, it is necessary to select pins 5 to 8 (one or more at a time). Binary weighting $n + 1$.

Combinations of the pins to be activated to select the programs

Program number	Pin 5 (input 3)	Pin 6 (input 4)	Pin 7 (input 5)	Pin 8 (input 6)
1	0	0	0	0
2	1	0	0	0
3	0	1	0	0
4	1	1	0	0
5	0	0	1	0
6	1	0	1	0
7	0	1	1	0
8	1	1	1	0
9	0	0	0	1
10	1	0	0	1
11	0	1	0	1
12	1	1	0	1
13	0	0	1	1
14	1	0	1	1
15	0	1	1	1
16	1	1	1	1

**2.2.1. 5) J3 connector (Inputs/Outputs All or Nothing)
programmable input**

Input 7 can be programmed in the **CONFIGURATION/INPUT 7** menu.

The functions programmable on this input are all the special cycles, which are :

- ✓ Program selection,
- ✓ Regulator adjustment request,
- ✓ Infinite fill request,
- ✓ Piezo reset request,
- ✓ Manual differential reset request,
- ✓ Calibration learning request,
- ✓ Calibration check request,
- ✓ ATR learning request,
- ✓ Reference adjustment request.

Some possibilities only appear if the function is used.

2.2.1. 6) J3 connector (Inputs/Outputs AON) diagram

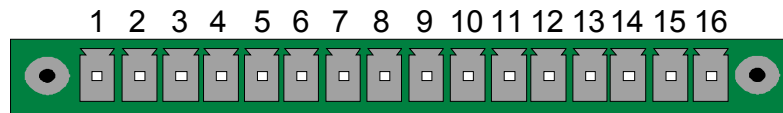

a) PLC in NPN mode connection

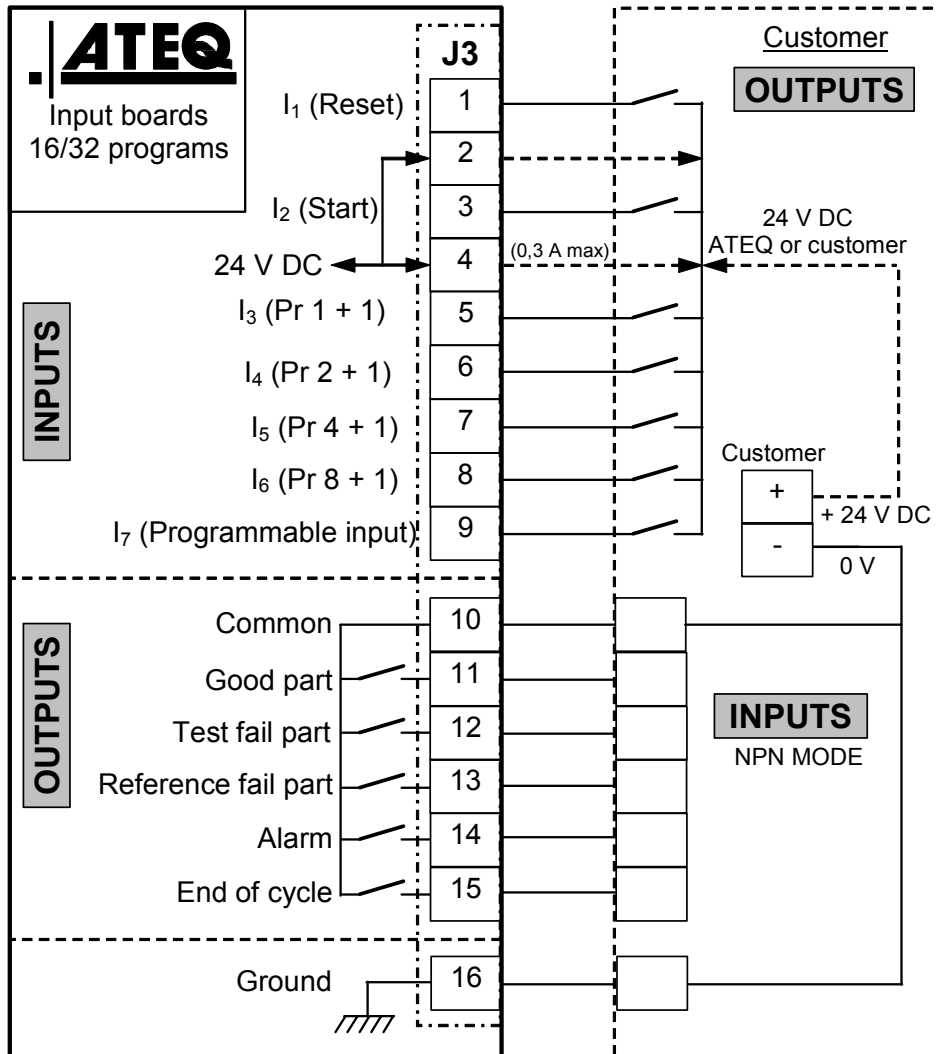

Note: The 24V power supply must be provided by the internal power supply of the ATEQ instrument (0,3A maximum) **OR** through an external power supply provided by the customer.

In the case of customer external supply, the ATEQ instrument can be supply by the 2 and 4 pins on the J3 connector too.

b) PLC in PNP mode connection

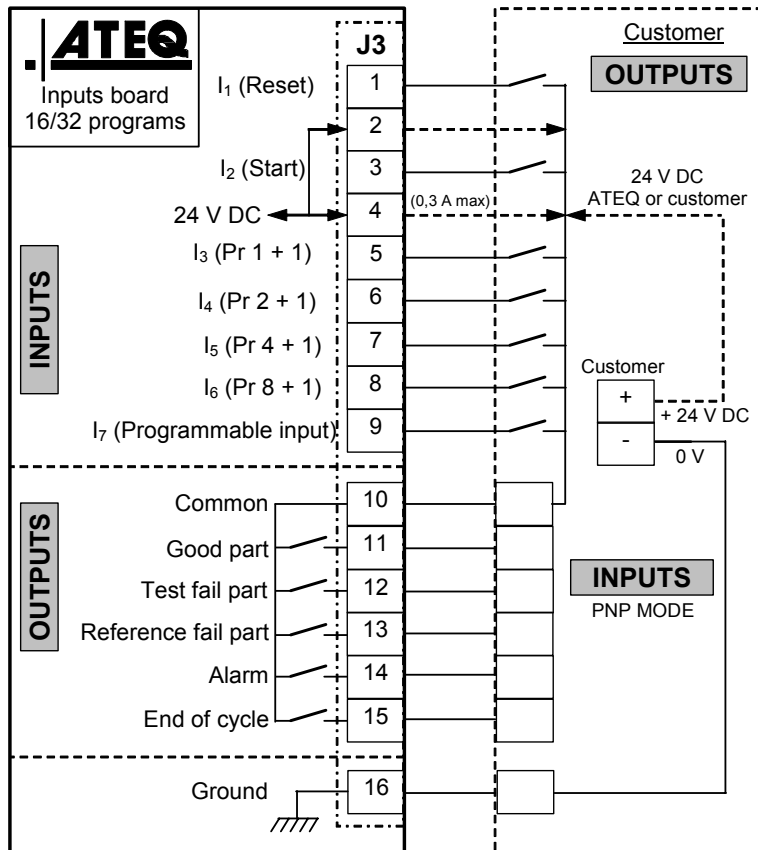

Note: The 24V power supply must be provided by the internal power supply of the ATEQ instrument (0,3A maximum) **OR** through an external power supply provided by the customer.

In the case of customer external supply, the ATEQ instrument can be supply by the 2 and 4 pins on the J3 connector too.

c) Lights connection

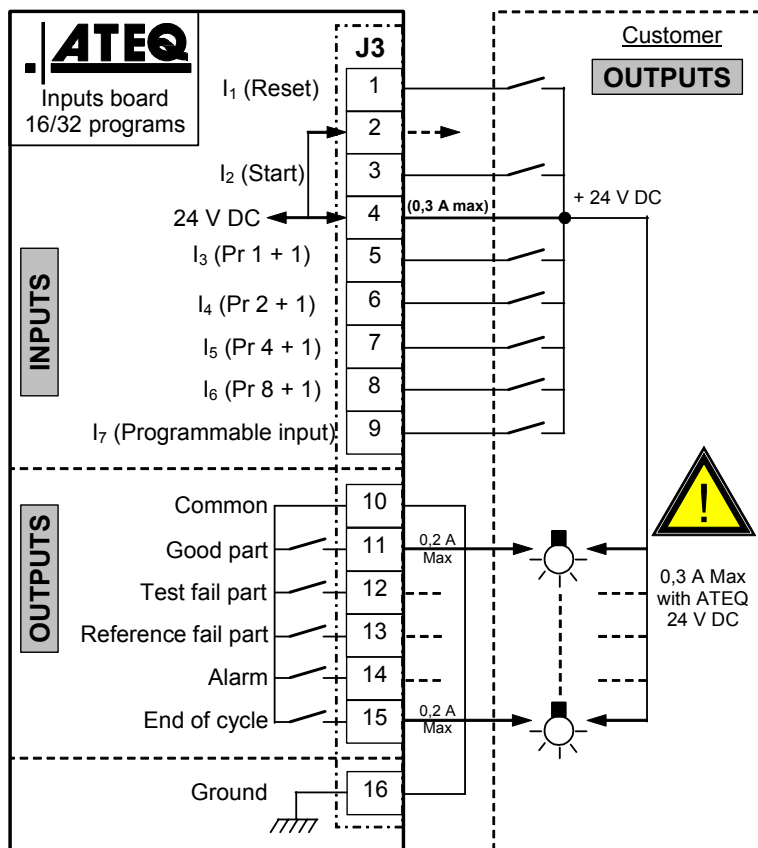

Note: The 24V power supply must be provided by the internal power supply of the ATEQ instrument (0,3A maximum) **OR** through an external power supply provided by the customer.

In the case of customer external supply, the ATEQ instrument can be supply by the 2 and 4 pins on the J3 connector too.

2.2.1. 7) J4 connector



Allows the connection of the power supply.

The instrument can be powered directly through the relay board J3 connector on one of the 24 V DC pins.

2.2.1. 8) J5 remote control connector (RS232)

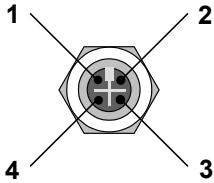

Allows the connection of an intelligent remote control. (Female Lumberg type connector). Optional.

PIN 1	Network (TXD)	PIN 3	Network (RXD)
PIN 2	Power + 24V	PIN 4	Ground 0V

2.2.1. 9) J6 input connector (RS485)

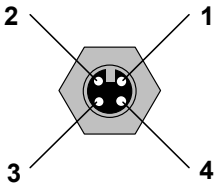

ATEQ only network.

Allows the connection to other **ATEQ** instruments. (Male Lumberg type connector).

PIN 1	Network (D+)	PIN 3	Network (D-)
PIN 2	Power + 24 V	PIN 4	Ground 0V

2.2.1. 10) J7 output connector (RS485)

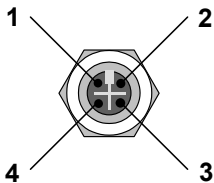

ATEQ only network.

Allows the connection to other **ATEQ** instruments. (Female Lumberg type connector).

PIN 1	Network (D+)	PIN 3	Network (D-)
PIN 2	Power +24V	PIN 4	Ground 0V

2.2.1. 11) J8 connector (RS232)

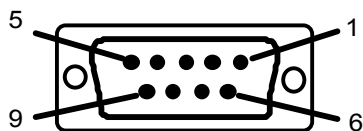

Allows the connection of a printer, a bar code reader, a PC, a memory module.

PIN 1	Not connected	PIN 6	+ 5 V DC 200 mA max
PIN 2	RXD Reception of the data	PIN 7	RTS request to send
PIN 3	TXD Sending of the data	PIN 8	CTS clear to send
PIN 4	Not connected	PIN 9	Not connected
PIN 5	Ground		

2.2.1. 12) Examples of RS232 cables

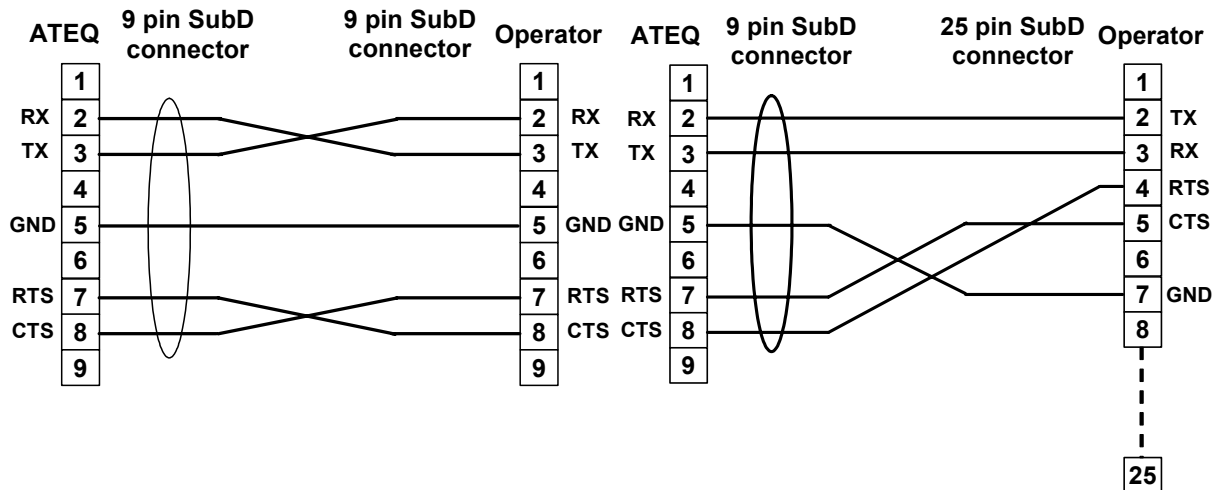

2.2.2. Pneumatic connectors

For the **ATEQ D520**, the automatic connectors can be installed on the front panel or on the rear panel depending on the option chosen.

These pneumatic outputs can take on different functionalities depending on the configuration requested following the purchase of the instrument (stamping, cut off, dump, second test output, etc.).

"Automatic connector A" output	"Automatic connector B" output
Automatic connector A	Automatic connector B
Automatic connector A	Stamping
Automatic connector A	Cut off
Stamping	External dump

2.2.2. 1) Automatic connector A



Allows the pneumatic management of a sealing jig.

2.2.2. 2) Automatic connector B



Allows the pneumatic management of a second sealing jig.

2.2.2. 3) Take pressure socket (option)

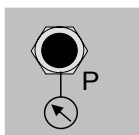

This optional connector allows to plug the absolute pressure sensor the nearest as possible to the part to be controlled. Connector dimensions: 2.7/4 tube.

2.2.2. 4) Test pneumatic inputs / outputs

These outputs allow the connection of the parts.

Direct flow measurement mode output:

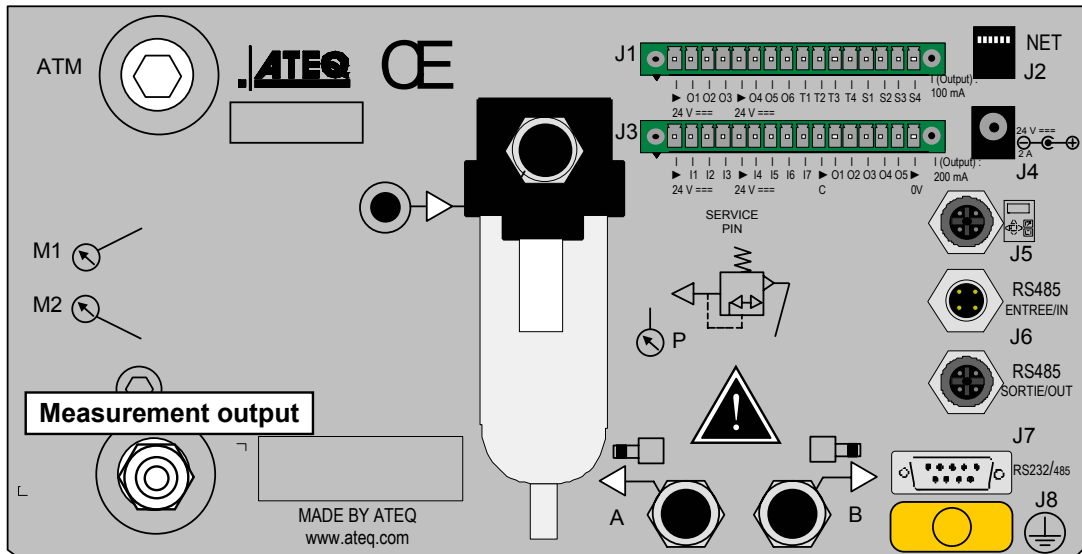

Indirect flow measurement mode output:

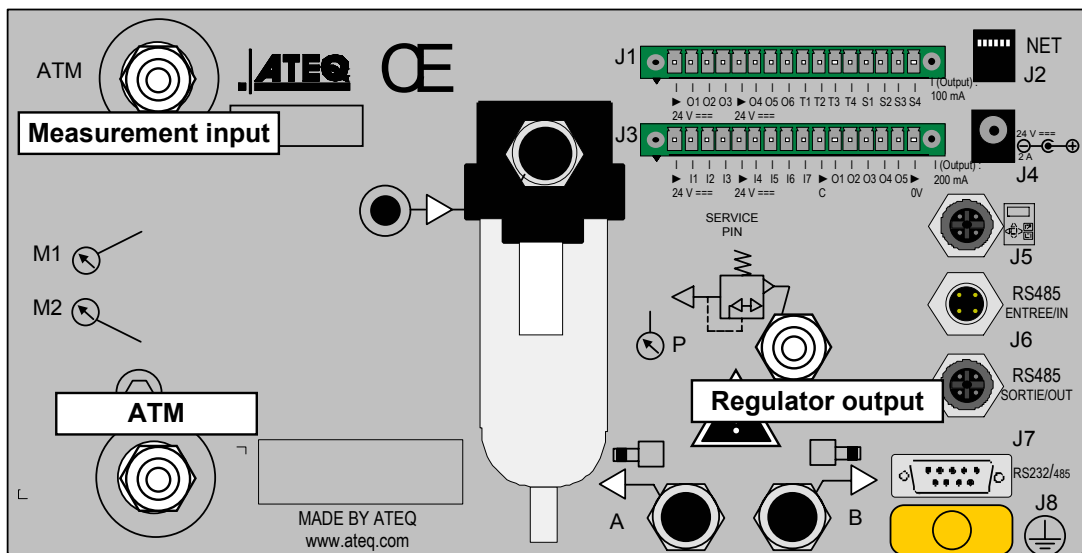

2.2.2. 5) "Gas" option

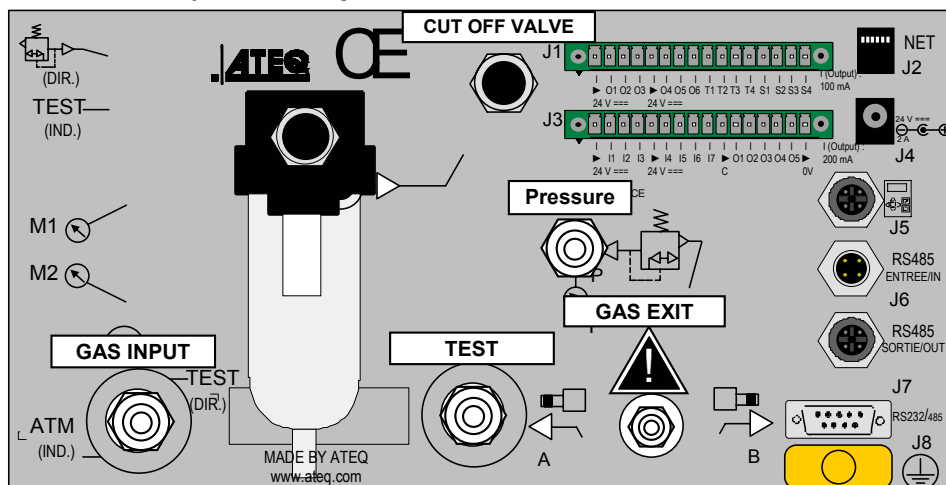

2.2.2. 6) Pneumatic air supply

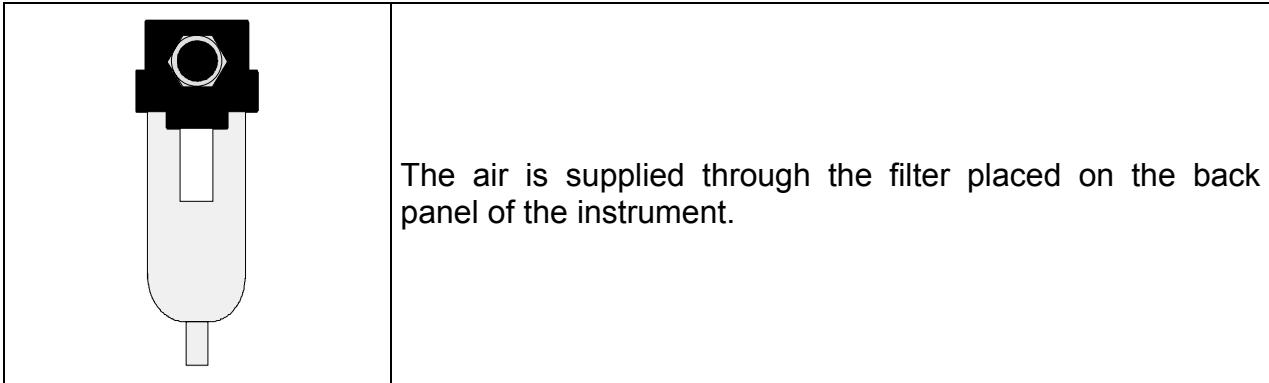

The air supply must absolutely be clean and dry. The presence of dusts, oil or impurities, causes a risk of improper operation of the instrument despite the filter supplied.

When the instrument operates in vacuum the entry of debris into the instrument must be avoided. For this purpose it is highly recommended that an appropriate leak proof filter is fitted between the test part and the instrument. This filter can be supplied by **ATEQ**.

The presence of impurities, oil or humidity in the air may cause a deterioration for which the guarantee will not be valid.

According to the ISO 8573-1 norm concerning the quality levels of compressed air for measurement instruments in industrial environments:

ATEQ recommends:

- | | | |
|--------------------------------|---------|-------------------------------------|
| • Grain size and concentration | CLASS 1 | (0,1 µm and 0,1 mg/m ³) |
| • Dew point under pressure | CLASS 2 | (- 40° of dew) |
| • Maximal concentration in oil | CLASS 1 | (0,01 mg/m ³) |

ATEQ recommends the installation:

- Of an air drier allowing the obtaining of a dry air with a dew point at less than - 40°,
- Of a 25 microns and 1/100 of a micron double filter.

Optimisation of the operation:

The air supply pressure must be between 400 kPa and 800 kPa (4 and 8 bar) to ensure a perfect operation of the pneumatic distributors.

In the event of the use of a mechanical regulator, it is necessary to have an air pressure supply which is at least 100 kPa (1 bar) over the test pressure with a minimum of 400 kPa (4 bar).

In the event of the use of an electronic regulator, the input pressure must be at least 10 % over the full scale value of the electronic regulator + 100 kPa (+ 1 bar).



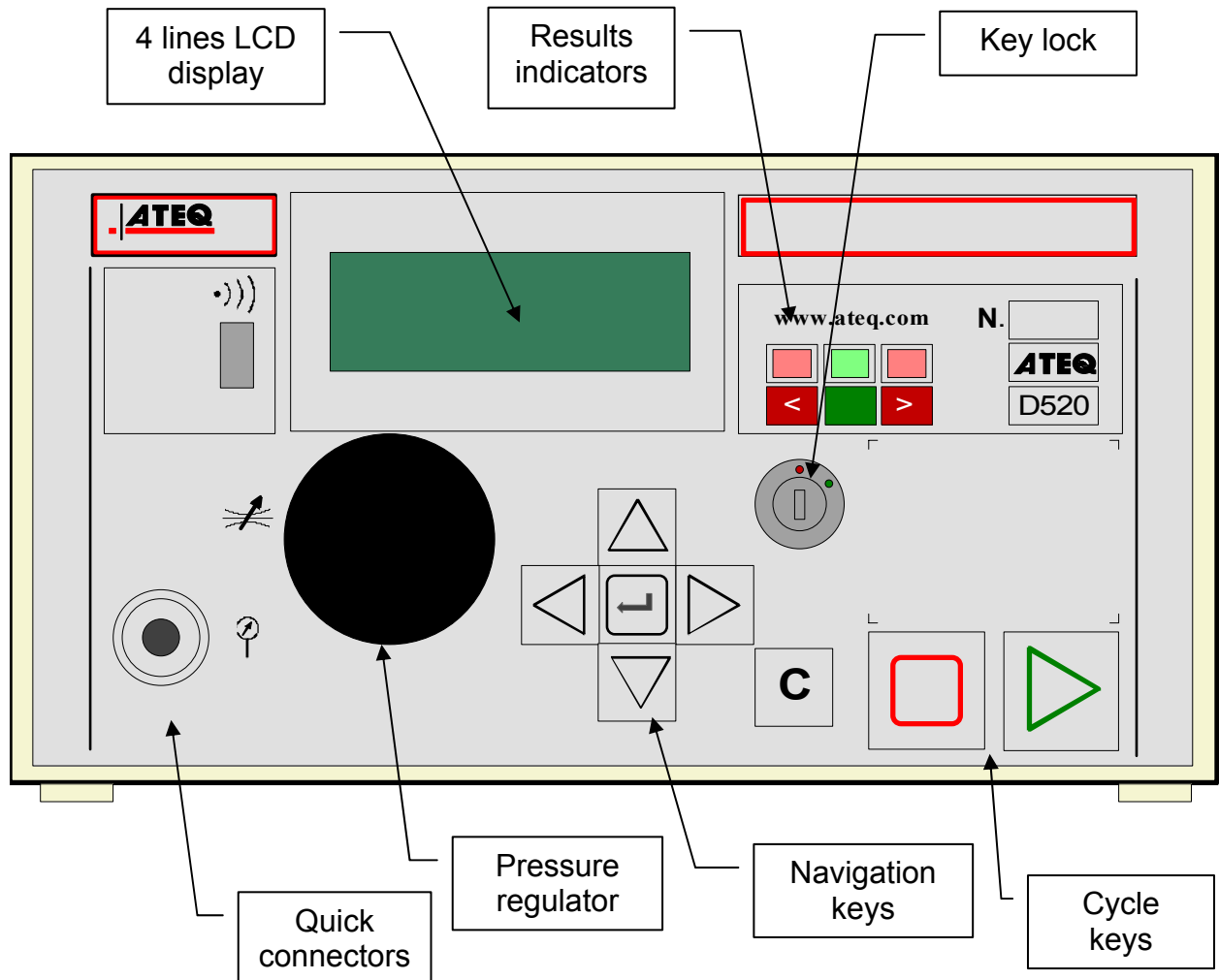

Chapter 2 USER INTERFACES

1. PRESENTATION OF THE FRONT PANEL OF THE D520

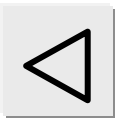

2. PRESENTATION OF THE KEYBOARD KEYS

2.1. NAVIGATION KEYS

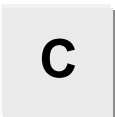
KEY	FUNCTION
	Move up or increase of the numerical values
	Move down or decrease of the numerical values
	Not used
	Not used
	ENTER key Enter the Parameter edition menu Validation of a parameter
	« C » for CANCEL Return to the previous menu or function Escape a parameter without modifying it

2.2. CYCLE KEYS

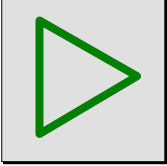
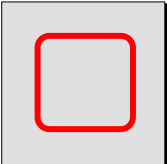
KEY	FUNCTION
	<p>START key Launching a measurement cycle</p>
	<p>Reset key (Reset to 0) Stopping of the measurement cycle in progress</p>

3. KEY LOCK

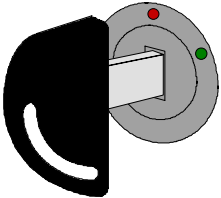
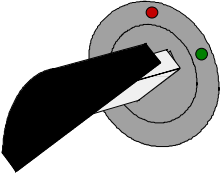
POSITION	FUNCTION
	<p>LOCK position. The access to the adjustable parameters is not possible.</p>
	<p>ACCESS position. Access to the adjustable parameters.</p>

Note: whatever the position of the key-lock is (**LOCKED** or **ACCESS**), it is possible to start and stop test cycles.

4. REGULATOR

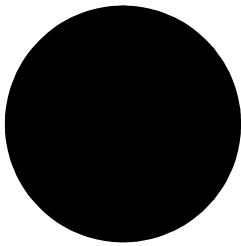

Allows the adjustment of the test pressure.

5. INFRA-RED INTERFACE

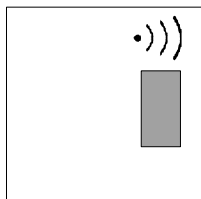

Not functional.

6. 4 LINE LCD DISPLAY

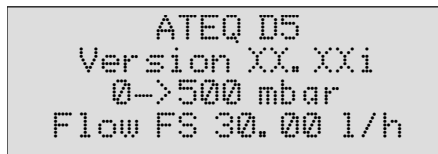

Allows the display of the measurements and adjustable parameters. In the example to the left, XX.XXi represents the program version of the instrument.

7. QUICK CONNECTOR

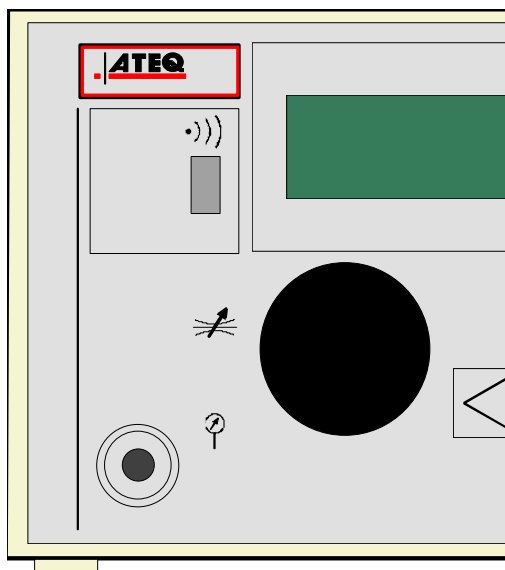

A quick connector may be mounted on the front panel of the instrument. It allows the easy checking of the pressure. It is used for the regulator circuit. It allows the checking of the test pressure displayed by the instrument with a precision manometer or the **ATEQ Leak/Flow calibrator**.

8. FUNCTIONNALITY OF THE INDICATORS

The  symbol represents a lit indicator.

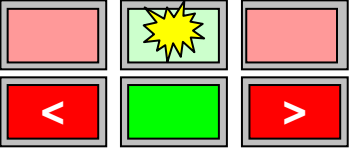
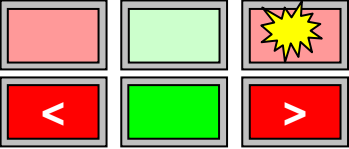
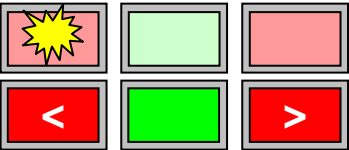
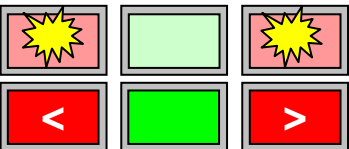
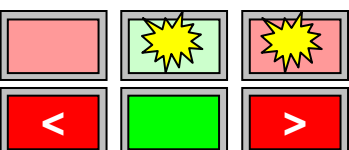
<p>Pass part indicator.</p>	
<p>Fail large flow indicator (flow too big).</p>	
<p>Fail low flow indicator (flow too weak).</p>	
<p>Warning.</p>	
<p>Standby, (intermittent flashing).</p>	
<p>Recoverable parts (indicator constantly lit).</p>	

Chapter 3

STARTUP AND ADJUSTMENTS**1. POWERING UP THE ATEQ D520**

Supply the instrument with 24 V DC. When switched on the instrument :		
displays the version and the sensor full scales ...		<pre> ATEQ D5 Version XX.XXi 0-> 2 bar Flow FS 5 L/h </pre>
...then displays the main menu.		<pre> RUN/Pr: 001 PRESS = 0.000 bar READY </pre>

2. CREATION OF A TEST PROGRAM

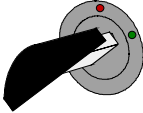
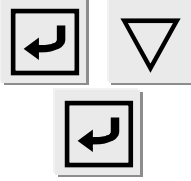

<p>To be able to modify the parameters, place the key in the ACCESS position.</p>		<pre> RUN/Pr : 001 PRESS = 0.000 bar READY </pre>
<p>To access the main menu, press on the ENTER key. From the main menu, place the cursor in front of the PARAMETERS menu. Confirm with the ENTER key.</p>		<pre> MAIN MENU RUN PROG. : --- PARAMETERS SPE CYCLE: Disabled </pre>
<p>The PARAMETERS menu allows the management of test programs.</p> <ul style="list-style-type: none"> ☞ If the different programs to be created have different parameters, it is necessary to create them one by one. ☞ If these programs have identical parameters, a base program can be created and the Copy – Paste function used to duplicate this program as many times as necessary. 		<pre> PARAMETERS Copy-Paste Pr : 01 ----- Pr : 02 ----- </pre>

2.1. CHOICE OF THE PROGRAM NUMBER

<p>Position the cursor in front of the chosen program number. Confirm with the ENTER key.</p>		<pre> PARAMETERS Copy-Paste PARAMETERS Pr : 01 ----- Pr : 02 ----- </pre>
--	---	---

2.2. SELECTION OF THE TEST TYPE

Two test types are available.

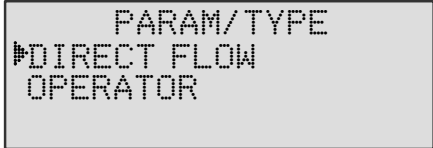
<p>The PARAMETERS menu gives access to two possible test types: Indirect or direct flow test (FLOW. CYCLE) and an operator test (OPERATOR) non functional; refer to the following paragraph for explanations. Place the cursor in front of the required test type and confirm with the ENTER key.</p>	 	 <pre> PARAM/TYPE DIRECT FLOW OPERATOR </pre>
---	---	---

2.2.1. Flow test (direct or indirect)

When a fluid (gas) passes through a calibrated flow tube (laminar flow), a pressure drop takes place, the value of which is proportional to the flow.

2.2.2. Test with reference



This kind of test is an option. It's named "Rich" or "High Precision". It's allows shifting the pneumatic circuit to a master (reference program), this is to make a learning before measuring on the test part (flow program).

The master characteristics are to be informed in the (single) "reference" program. See the "reference" function in the chapter 4.

Procedure for test with reference:

- Program the reference cycle.
- Program the flow test cycles with the same parameters as the reference one.
- Activate the reference function in the flow cycle.







2.2.3. Operator mode test

This test type allows the operator to carry out actions (or checks) on the part undergoing a test then to confirm them with the **"START"**  key if the test is considered to be good, or on the **"RESET"**  key if the test is considered to be bad.

2.3. ADJUSTMENT OF THE PARAMETERS

Once the test type is chosen, the cycle parameters must be adjusted.

The procedure to follow to adjust all the test parameters is identical. Example with the Coupling time A.

<p>First, place the cursor in front of the chosen parameter with the navigation keys (here, wait time A).</p>		<pre>PARAM/Pr001 TYPE : DIRECT FLOW COUPL. A : 00.00 s FILL : 00.00 s</pre>
<p>Next, confirm with the ENTER key. The cursor moves to the right hand side of the screen.</p>		<pre>PARAM/Pr001 TYPE : DIRECT FLOW COUPL. A : 00.00 s FILL : 00.00 s</pre>
<p>Modify the value with the navigation keys.</p>		<pre>PARAM/Pr001 TYPE : DIRECT FLOW COUPL. A : 00.03 s FILL : 00.00 s</pre>
<p>Once the value is modified, confirm with the ENTER key.</p>		<pre>PARAM/Pr001 TYPE : DIRECT FLOW COUPL. A : 03.00 s FILL : 00.00 s</pre>
<p>To move to the next parameter, use the navigation keys.</p>		<pre>PARAM/Pr001 TYPE : DIRECT FLOW COUPL. A : 03.00 s FILL : 00.00 s</pre>
<p>To exit the menu, use the CANCEL key.</p>		<pre>PARAMETERS Copy-Paste Pr: 001 FLOW Pr: 002 FLOW</pre>

2.3.1. Coupling time

The coupling (also known as wait) times A and B are cycle start parameters.

When there is no automatic connector, the coupling time A is a part of the cycle.

In the event of an instrument with automatic connector the coupling time A allows the activation of a first connector as soon as the cycle starts and to delay the pressurisation of the test part. The coupling time B allows the activation of a second automatic connector. These coupling times ensure a better stabilisation of the seals placed on the test part.

☞ Adjust this parameter according to the method described in § 2.3.

2.3.2. Fill time

This is the time taken to pressurise and initialise the flow in the test part.

☞ Adjust this parameter according to the method described in § 2.3.

2.3.3. Stabilisation time

This time allows the stabilisation of the flow in the part. If the stabilisation time is too short, parasite flow variations can cause inaccurate readings.

It is therefore recommended to start with a long stabilisation time and to progressively reduce it until a stable reading of flow can be made.

☞ Adjust this parameter according to the method described in § 2.3.

2.3.4. Test time

The test time can be a set value or infinite. During all this time the instrument indicates if the flow in the part measured is between the minimum and maximum reject values.



When the test time is infinite, the fill pressure monitoring is inoperative. It is therefore necessary to be careful not to apply an excessive pressure to the part being tested.

☞ Adjust this parameter according to the method described in § 2.3.

2.3.5. Pressure unit

The different units are: bar, mbar, PSI, Pa, kPa, MPa.

☞ Adjust this parameter according to the method described in § 2.3.

2.3.6. Max fill

This function allows the setting of a maximum fill pressure which sets off an alarm if it is exceeded.

☞ Adjust this parameter according to the method described in § 2.3.

2.3.7. Min fill

This function allows the setting of a minimum fill pressure threshold which sets of an alarm if the pressure is not reached. This function is not active when an infinite test time is set.

☞ Adjust this parameter according to the method described in § 2.3.

2.3.8. Reject unit

The reject units available depending on the system chosen by the operator are:

SI System: ml/h, l/h, ml/s, ml/min.

USA System: in³/h, ft³/h, in³/min, in³/h, ft³/h, in³/min.

Personalised system: no units, as chosen by the operator (CAL) only a unit name is required, then the input of the maximum authorised drift. A learning cycle is then necessary; it is carried out through the "**CAL learning**" special cycle.

☞ Adjust this parameter according to the method described in § 2.3.

2.3.9. Maximum reject

This parameter allows the definition of the upper limit of the authorised flow range in the test part, above this limit the part is considered as bad.

☞ Adjust this parameter according to the method described in § 2.3.

2.3.10. Minimum reject

This parameter allows the definition of the lower limit of the authorised flow range in the test part, under this limit the part is considered as bad.

☞ Adjust this parameter according to the method described in § 2.3.

2.3.11. Range (second capillary option)

The second capillary is an option on the D520 instrument, it allows having two flow measurement ranges so that to have best adapt of the measurement extend of the capillary in function of the part to be controlled.

When this option exists in the instrument, the "Range" parameter appears in the parameters menu, so you have to choose the capillary (the range), then the best measurement range adapted to the part to be controlled.

The choice of the range is function of the capillaries installed in the instrument: the available ranges are: 5 l/h, 30 l/h, 150 l/h, 500 l/h, 1500 l/h, 4000 l/h and 10000 l/h.

☞ Adjust this parameter according to the method described in § 2.3.







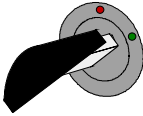

2.3.12. Functions

The **FUNCTION** menu allows access to additional parameters which must first be activated in the **CONFIGURATION** menu, then in **EXTENDED MENUS**.

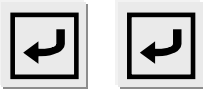
If no additional parameters have been activated in the **EXTENDED MENUS**, the **FUNCTION** menu is empty.



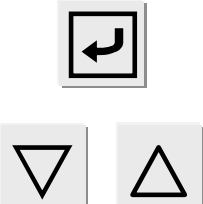



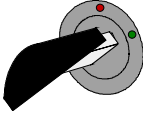

To activate these parameters, refer to chapter 4 § 2.

3. COPYING A TEST PROGRAM

<p>To be able to modify the parameters, place the key in the ACCESS position.</p>		
<p>From the main menu, place the cursor in front of the PARAMETERS heading.</p>		<pre> MAIN MENU RUN PROG. : 001 PARAMETERS SPE CYCLE: Disabled </pre>
<p>Validate with the ENTER key. The cursor will place itself in front of the Copy-Paste function. Confirm this function again with the ENTER key.</p>		<pre> PARAMETERS Copy-Paste Pr : 001 VALVE 1 Pr : 002 VALVE 2 </pre>
<p>Next, validate the COPY function.</p>		<pre> PARAM/Copy-Paste COPY : Pr --- PASTE : Pr --- </pre>
<p>Display the number of the program to be copied by using the navigation arrows. (Here, program n°1).</p>		<pre> PARAM/Copy-Paste COPY : Pr 001 PASTE : Pr --- </pre>
<p>Confirm with the ENTER key.</p>		<pre> PARAM/Copy-Paste COPY : Pr 001 PASTE : Pr --- </pre>
<p>Place the cursor in front of Paste.</p>		<pre> PARAM/Copy-Paste COPY : Pr 001 PASTE : Pr --- </pre>
<p>Confirm with the ENTER key. Attribute a number to this new program by using the navigation keys (for example n°3).</p>		<pre> PARAM/Copy-Paste COPY : Pr 001 PASTE : Pr 003 </pre>
<p>Confirm with the ENTER key. The display confirms the copy of the program.</p>		<pre> COPY IN PROGRESS... </pre>





<p>From this moment, the parameters for program 1 are duplicated into program 3. In this example, program n°3 is therefore an exact copy of program n°1.</p>		<pre> PARAM/Copy-Paste COPY : Pr 001 PARAMETERS #PASTE : Pr 003 </pre>
<p>Press twice on CANCEL to return to the main menu.</p>	<p>C C</p>	<pre> MAIN MENU RUN PROG : 001 PARAMETERS #PARAMETERS SPE CYCLE : Disabled </pre>

4. DELETING A PROGRAM OR THE NAME OF A PROGRAM

<p>To be able to modify the parameters, turn the key to the ACCESS position.</p>		
<p>Position the cursor in front of PARAMETERS. Confirm with the ENTER key.</p>		<pre> MAIN MENU RUN PROG. : 001 PARAMETERS SPE CYCLE: Disabled </pre>
<p>Place the cursor in front of the program number to be deleted or the name of the program to be deleted.</p>		<pre> PARAMETERS Copy-Paste Pr: 001 VALVE 1 Pr: 002 VALVE 2 </pre>
<p>Confirm a first time to enter the program.</p>		<pre> PARAM/Pr001 TEST : PRESS. CYCLE COUPL. A : 00.0 s INIT.PRES: 0000 </pre>
<p>Confirm a second time to gain access to the delete menu. Two possibilities are available: delete the name of the program or delete the whole program.</p>		<pre> M/Pr001/TEST TYPE Delete name Delete program </pre>
<p>1°) Confirm a third time. The name of the program is deleted.</p>		<pre> PARAMETERS Copy-Paste Pr: 001 ----- Pr: 002 VALVE 2 </pre>
<p>2°) Place the cursor in front of delete program.</p>		<pre> M/Pr001/TEST TYPE Delete name Delete program </pre>
<p>Confirm with ENTER. The program is deleted. Note: if the "Delete a program" operation is done first, then the program name is also deleted.</p>		<pre> PARAM/Pr001 TEST : PRESS. CYCLE COUPL. A : 00.0 s INIT.PRES: 0000 </pre>







5. LAUNCHING OF A CYCLE

5.1. CHOICE OF THE PROGRAM NUMBER TO BE LAUNCHED

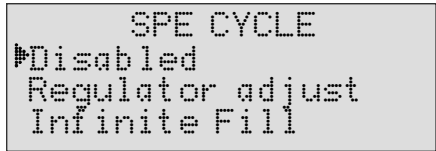
<p>Position the key in the ACCESS position.</p>		
<p>Starting from the main menu, place the cursor in front of the RUN PROG. function.</p>		<pre> MAIN MENU ▶RUN PROG.: 001 PARAMETERS SPE CYCLE : Disabled </pre>
<p>Confirm with the ENTER key.</p>		<pre> MAIN MENU ▶RUN PROG.: 001 PARAMETERS SPE CYCLE : Disabled </pre>
<p>Display the number of the program required by scrolling through the numbers with the navigation keys.</p>		<pre> MAIN MENU RUN PROG. : 004 ◀ PARAMETERS SPE CYCLE : Disabled </pre>
<p>Confirm your choice with the ENTER key.</p>		<pre> MAIN MENU ▶RUN PROG. : 004 PARAMETERS SPE CYCLE : Disabled </pre>

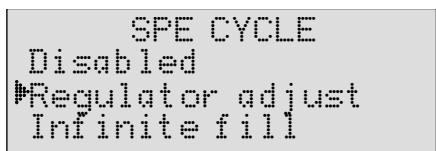
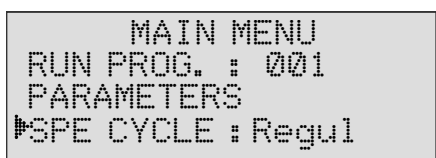
5.2. SETTING THE TEST PRESSURE

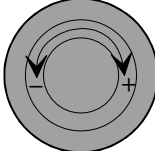
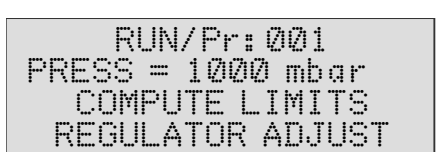
5.2.1. Manual setting with a mechanical regulator

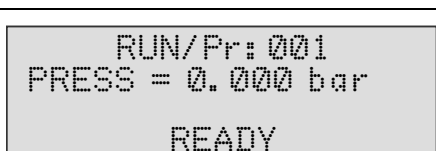
Position the cursor in front of the SPE CYCLE function and confirm with the ENTER key.		
Next, position the cursor in front of Regulator adjust and confirm with the ENTER key.		
The display confirms that the special cycle has been selected.		
Press the START key to launch a special cycle.		
Set the test pressure by using the regulator.		
Once the pressure is set, press the RESET key to stop the special cycle.		

5.2.2. Setting an instruction with an electronic regulator

5.2.2. 1) Pressure adjustment

When the instrument is equipped with an electronic regulator, the test pressure value is that which is displayed as the fill instruction. There is no special cycle to be carried out.

To input a fill instruction, refer to the previous paragraph.

Reminder: the input pressure with an instrument fitted with an electronic regulator must be at least superior by 100 kPa (1 bar) of the test pressure.

6. STARTING A MEASUREMENT CYCLE

<p>Press the START key to start a measurement cycle.</p>		<pre> RUN/Pr: 004 PRESS =0.500 bar READY </pre>
<p>The cycle phases are displayed on the LCD window:</p> <p>COUPL., FILL, STAB, TEST.</p>		<pre> RUN/Pr: 004 PRESS =1.00 bar STABILISATION </pre>

7. STOPPING A CYCLE

<p>Press the RESET key to stop the measurement. The display "READY" indicates that the instrument is ready to perform a new measurement test.</p>		<pre> RUN/Pr: 004 PRESS =0.500 bar READY </pre>
---	--	--

Chapter 4

FUNCTIONS OF THE INSTRUMENT

1. MENU STRUCTURE

1.1. MAIN MENU

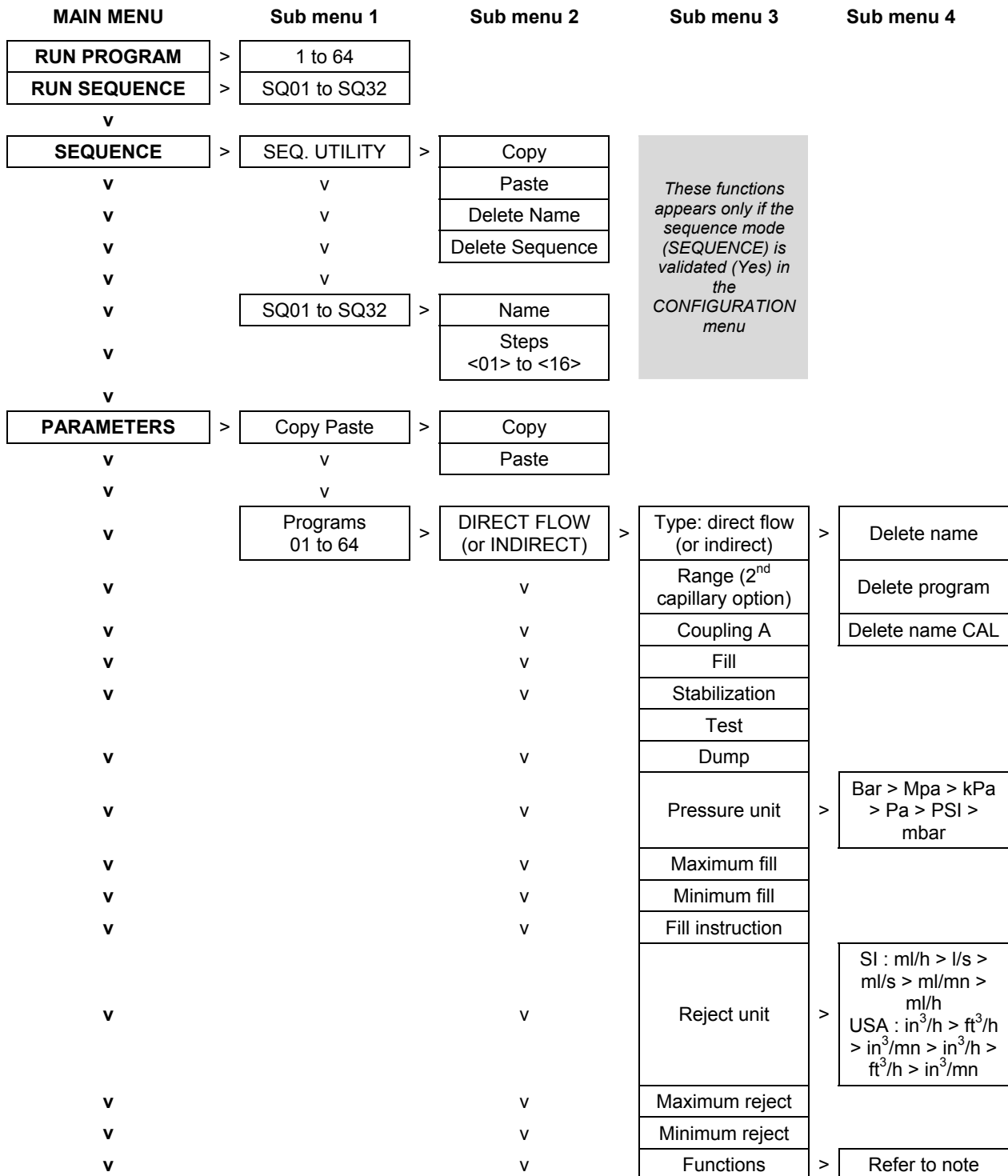

Chapter 4 – Functions of the instrument

v		REFERENCE	>	Type : reference	>	Delete name
v		v		Coupling A		Delete program
v		v		Fill		
v		v		Stabilization		
v		v		Test		
v		v		Dump		
v		v		Pressure unit	>	Bar > MPa > kPa > Pa > PSI > mbar
v		v		Maximum fill		
v		v		Minimum fill		
v		v		Fill instruction		
v		v		Reference flow		
v		v		Reference unit	>	SI : ml/h > l/s > ml/s > ml/mn > ml/h USA : in3/h > ft3/h > in3/mn > in3/h > ft3/h > in3/mn
v		v		Reference pressure		
v		v		Reference atmospheric pressure		
v		v		Reference temperature		
v		v		Reference drift		
v		v		Functions	>	Refer to note
v		v		OPERATOR	>	Type: operator
v				Coupling A		Delete name
v				Test		Delete program
v				Functions	>	Refer to note
v		SPECIAL CYCLES	>	Disabled		
v		v		Electronic regulator learning		
v		v		Regulator adjustment		
v		v		Infinite fill		
v		v		CAL learning		
v		v		CAL check		
v		v		ATR learning		
v		v		Atmospheric conditions		
v		v		Reference calibration		
v		v		Piezo auto zero		
v		CONFIGURATION	>	Extended menus	>	Name
v		v		v		Cycling

Chapter 4 – Functions of the instrument

v		v	
v	v	v	Reference
v	v	v	Automatic mode
v	v	v	Units
v	v	v	Filter
v	v	v	Standard conditions
v	v	v	Pressure correction
v	v	v	Pressure auto zero
v	v	v	Offset
v	v	v	ATR1
v	v	v	ATR2
v	v	v	Peak hold
v	v	v	Recovery thresholds
v	v	v	P1 – P2
v	v	v	P1 –P2 correction
v	v	v	Fill type
v	v	v	Automatic connector
v	v	v	Valve codes
v	v	v	Stamping
v	v	v	Mini valve
v	v	v	No negative
v	v	v	Cycle end
v	v	v	Gas (option)
v	v	v	
v	v	v	Automatic save > Yes/no
v	v	v	
v	v	v	Sequence > Yes/no
v	v	v	
v	v	v	Ready status > Yes/no > Blow > Reference > test > stop
v	v	v	
v	v	v	Electronic Regulator > Instruction > zero
v	v	v	
v	v	v	Bar graph > yes / no > 30 % > 50 % > 70 % >
v	v	v	
v	v	v	Cal reference > Yes/no
v	v	v	
v	v	v	Regulator learning > yes / no > Frequency
v	v	v	Number of cycles
v	v	v	
v	v	v	Output configuration > Cut
v	v	v	reference
v	v	v	External 3

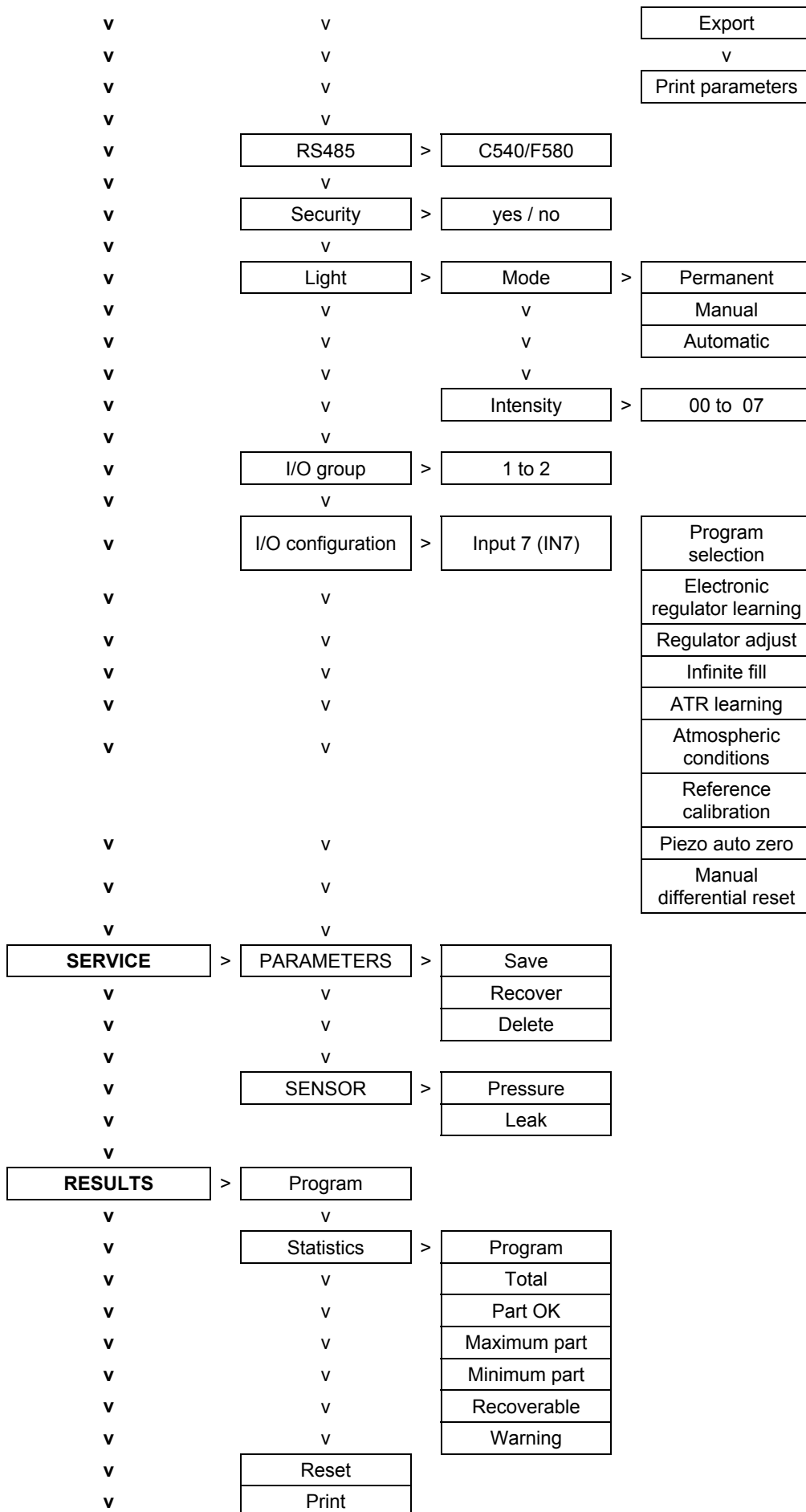

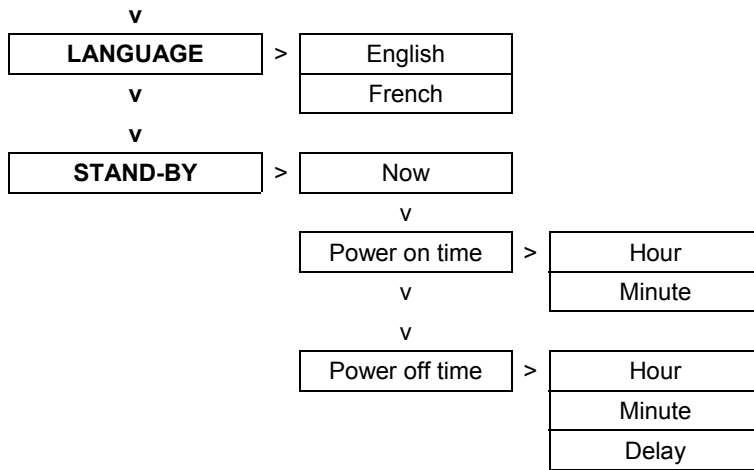

1.2. "FUNCTIONS" MENU WHEN ACTIVATED

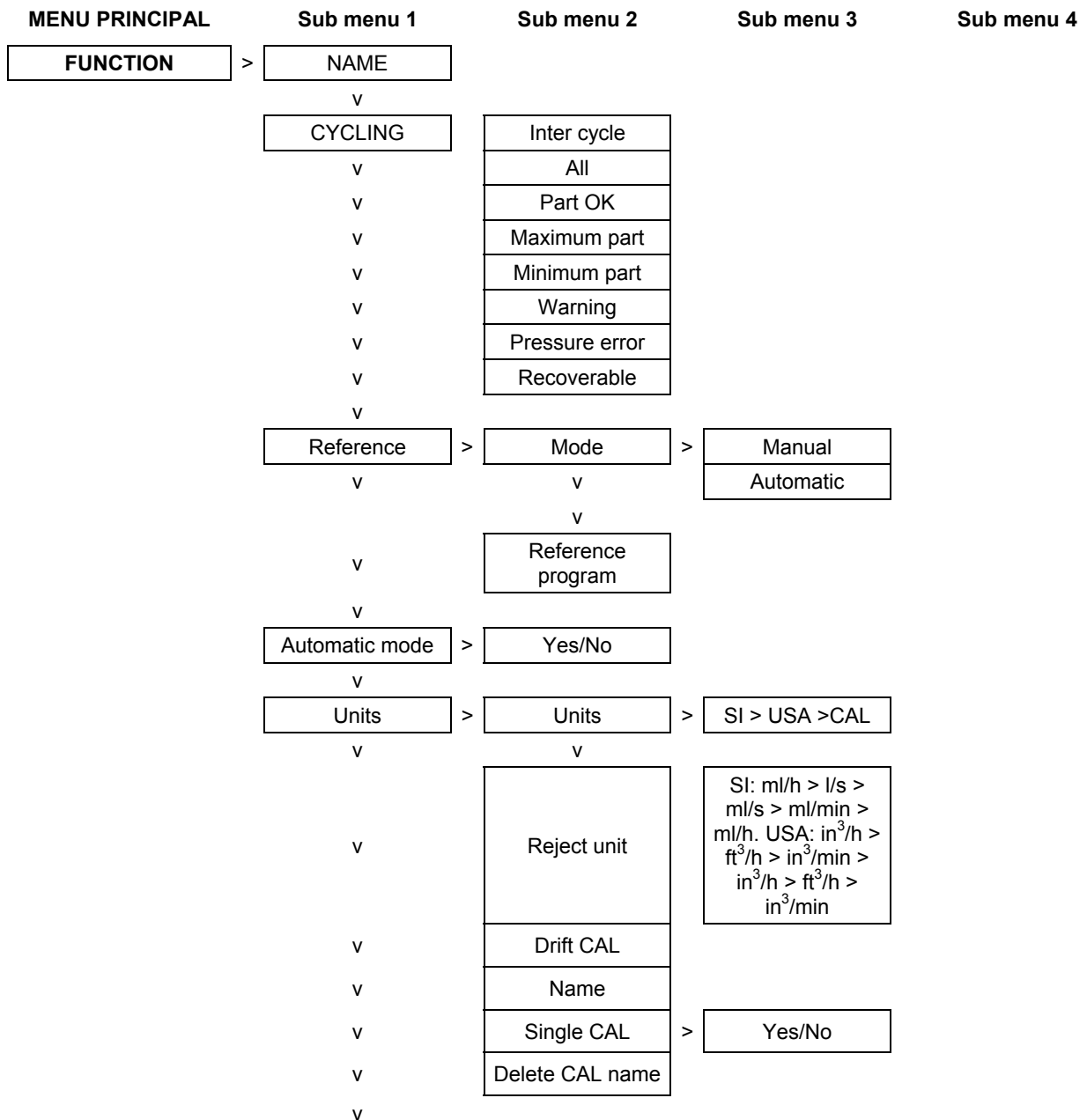

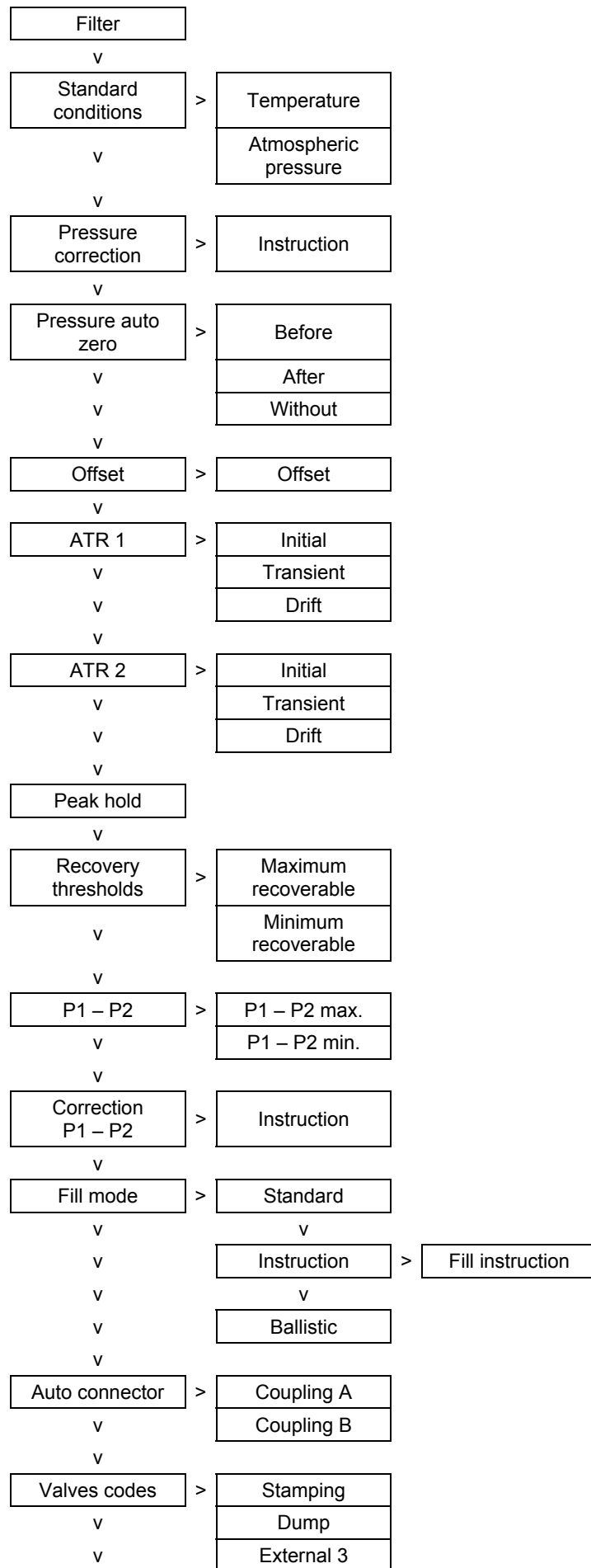

Chapter 4 – Functions of the instrument









v		External 4	
v		External 5	
v		External 6	
v		Stamping	
v		Dump	
v			
Stamping	>	Maintain	
v		all	
v		Part OK	
v		Maximum part	
v		Minimum part	
v		Warning	
v		Pressure error	
v			
Mini valve	>	Differential auto zero	
v			
No negative	>	Yes/No	
v			
Cycle end	>	Automatic reset	
		Dump + Reset	
		Fill	
Gas (option)	>	User gas	>
		v	Viscosity
		v	% / degree C
		v	Full scale flow
		G110	>
		v	Viscosity
		v	% / degree C
		v	Full scale flow
		Propane	>
		v	Viscosity
		v	% / degree C
		v	Full scale flow
		Butane	>
		v	Viscosity
		v	% / degree C
		v	Full scale flow
		Natural gas	>
		v	Viscosity
		v	% / degree C
		v	Full scale flow
		Nitrogen	>
		v	Viscosity
		v	% / degree C
		v	Full scale flow

2. CONFIGURATION MENU

2.1. EXTENDED MENUS

The extended menus give access to additional functions. If these functions are activated, they can be found under the **FUNCTIONS** menu when a program is created. If no additional function is activated, the **FUNCTIONS** menu is empty when a new program is created.

2.1.1. Activation of the additional functions

<p>In the main menu, place the cursor in front of the CONFIGURATION label.</p>		<pre> MAIN MENU CYCLE SPE: Disabled CONFIGURATION SERVICE </pre>
<p>Confirm using the ENTER key.</p>		<pre> CONFIGURATION EXTENDED MENUS BARGRAPH : Yes OUTPUTS CONF. </pre>
<p>Next, confirm the EXTENDED MENUS function with the ENTER key. The list of additional functions is displayed.</p>		<pre> CONFIG/EXTENDED MENU NAME : No CYCLING : No AUTO CONNECT : No </pre>
<p>To activate a function (e.g. the NAME function), validate it with the ENTER key. Next, choose YES with the navigation keys then confirm again with the ENTER key. Restart the operation if necessary to activate other functions.</p>	   	<pre> CONFIG/EXTENDED MENU NAME : Yes CYCLING : No AUTO CONNECT : No </pre>
<p>Once all the chosen functions have been activated, press twice on the CANCEL key to return to the main menu.</p>	 	<pre> MAIN MENU SPE CYCLE: Disabled CONFIGURATION RESULTS </pre>

2.1.2. Adjustment of the additional functions

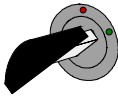
- ✓ Place the key in the **ACCESS**  position.
- ✓ Create a new program (refer to chapter 3 paragraph 2 "Creation of a test program").
- ✓ In the parameters list of this new program, validate the **FUNCTIONS** parameter (refer to chapter 3 paragraph 2.3 "Adjustment of the parameters").



Only the functions activated according to the method described in the previous paragraph will appear in the FUNCTIONS parameter.

2.1.3. List of additional functions

2.1.3. 1) Name

This function allows the personalization of a program, for example to identify it by the name of the test part.

☞ Select the option and adjust settings if necessary.

2.1.3. 2) Cycling

This function enables several tests to be carried out by the instrument one after the other.

The instrument offers 8 chaining criteria. When this function is activated it is possible to carry out a special "Step by Step" cycle as part of the initialization, which chains cycles without conditions.

Associated parameters to adjust: INTER-CYCLE (wait time between two cycles).
Chaining conditions: ALL (under all conditions), part good, rise error, drop error, warning, pressure error.

☞ Select the option and adjust settings if necessary.

2.1.3. 3) Reference

The validation of the "Reference" function in a flow cycle program is associating to this cycle the "Reference" cycle. During this "Reference" cycle, the measurement circuit is shifting to a circuit equipped by a master jet or a master part with known characteristics.

This proceeding is correcting the possible atmospheric conditions variations.

The activation of the "Reference" phase can be done by following two ways:

- Manually, the instrument shift to the reference circuit with the operator request, or automatic. Selection by the front panel or the inputs/outputs of the concerned program.
- Automatically the instrument shift to the reference circuit before each test cycle.

It must also configure the reference program with the master parameters.

- Calibration pressure.
- Master flow.
- Atmospheric pressure of the calibration.
- Calibration temperature.
- Drift.

The drift is calculated between the first and the last master jet measurement (reference cycle realization). If it's higher than the programmed level, a error message appears. Only a manual acquit can be possible ("Drift acquit" special cycle).

☞ Select the option and adjust settings if necessary.

2.1.3. 4) Automatic mode

This function launches the test cycle automatically, it therefore avoids the need for a pressing of the cycle start by the operator. The cycling of this test is on its own part.

The automatic function allows launching a test cycle as the part to be tested to the measurement circuit connection. The start cycle is made when the test pressure is between the minimum and the maximum levels.



In the case of use of the personalized measurements units (CAL) it's imperative to make a learning cycle before starting a test cycle. The learning error can generate an instrument blocking mode.

☞ Select the option and adjust settings if necessary.

2.1.3. 5) Units

This function allows the operator to choose the units system required: SI, international metric unit system, USA, Anglo-Saxon international units system (inches, feet) and CAL, the operator personalized unit system (this system requires the carrying out of a learning cycle).

☞ Select the option and adjust settings if necessary.

2.1.3. 6) Filtering

This function ensures the slowing or the acceleration the sampling speed, by carrying out an average over the measurement time set, making the reading of the measurement more user friendly.

☞ Select the option and adjust settings if necessary.

2.1.3. 7) Standard conditions

The "Standard conditions" function allows the returning of the results measured by the instrument to defined atmospheric conditions.

The measurements depend on the ambient temperature and atmospheric pressure. When the function is activated, the instrument recalculates the flow results according to the atmospheric conditions inputted. Therefore the results of the measurements will not take into account the ambient variations.

To confirm this function, an asterisk is displayed after "**FLOW**".

☞ Select the option and adjust settings if necessary.

2.1.3. 8) Pressure correction

The "pressure correction" function allows the conversion of the results by the instrument to a defined pressure instruction.

When the function is activated, the instrument recalculates the flow results depending on the instruction pressure. The measurement results will therefore no take into account pressure variations.

☞ Select the option and adjust settings if necessary.

2.1.3. 9) Pressure reset

The reset cycle in an ATEQ D520 instrument is carried out for each test cycle. This function allows the positioning of the auto zero (reset) in the test cycle. The positioning can be done BEFORE (just after the cycle start order and before the test cycle and before the test cycle), AFTER (just after the test time) or WITHOUT (no pressure auto zero).

☞ Select the option and adjust settings if necessary.

2.1.3. 10) Offset

This function allows the subtraction of the value set in the parameters from the value actually measured by the instrument. Example: if the measurement of the flow is of 14 litres a minute and the value of the offset set is of 5, then the instrument will display a flow value of 9 litres per minute ($9 = 14 - 5$).

☞ Select the option and adjust settings if necessary.

2.1.3. 11) ATR (Transient attenuation)

An ATR cycle enables time to be gained over a traditional cycle by enabling the stabilization time to be reduced and absorbing the transient pressure. The transient pressure is an unexpected drop in pressure caused by a stabilization time which is too short. The ATR may require a "**learning cycle**" to enable the transient pressure to be measured.

a) ATR1

The value of the transient is unknown. A special learning cycle must be carried out.

Associated parameters to be set: Initial (Initial value of the transient), Transit (actual and non modifiable value of the transient), Tolerance (Drift tolerance on acquisition of the transient, % of the reject level).

☞ Select the option and adjust settings if necessary.

Associated parameters to be adjusted: Max RECOV, Min RECOV.

If in multi measurement instrument configuration the parts are recoverable, the good part (POK) and bad part (PNOK) outputs are activated simultaneously.

☞ Select the option and adjust settings if necessary.

2.1.3. 14) P1 – P2 Function

This function allows the taking away of the pressure measurement of piezo sensor 2 (if installed depending on options) from that of piezo sensor 1.

```
CYCLE/Pr: 001
PRESS   : 18.9 mbar
FLOW    : 97.7 ml/s
P1-P2   : 18.9 mbar
```

☞ Select the option and adjust settings if necessary.

2.1.3. 15) P1 – P2 Correction

This function can on the basis of the P1 – P2 result (refer to the paragraph above) allow a correction to be made on the flow result of P1 - P2. Function similar to the function "pressure correction" paragraph 2.1.3.8.

☞ Select the option and adjust settings if necessary.

2.1.3. 16) Fill mode

This function gives the choice of three types of fill operation.

a) Standard

With a mechanical regulator

Adjust the value of the fill pressure manually by using the regulator handle during a "regulator adjust" special cycle.

With an electronic regulator

The fill pressure is adjusted automatically on the value chosen when the test program is created.

b) Instruction

The operator adjusts an instruction value for the fill pressure and opens the regulator. When the instruction pressure is reached the fill is stopped.

Associated parameters to be adjusted: **I. FILL** (Instruction fill).

c) Ballistic

This type of fill allows a fluctuation of the air pressure (filling of highly deformable parts) and enables an exceeding of the maximum fill threshold without stopping the cycle and delivering an error message. Never the less, to move into stabilization, the test pressure must be between the thresholds at the end of the fill.

2.1.3. 17) Automatic connector

The automatic connector is a pneumatic command allowing the control of an external logic (pneumatic seal jig). This command is carried out as soon as the cycle is started and stopped at the end of the cycle (refer to paragraph 2.1.3.22) "Cycle end").

If several programs are cycled the automatic connectors are activated with the set times in the first program and are deactivated with the time set for the last program in the cycle.

They remain active during all the cycles between the first and the last program in the chain.

The various coupling times are respected by the intermediate programs.

Associated parameters to be adjusted: COUPLING A, COUPLING B.

☞ Select the option and adjust settings if necessary.

2.1.3. 18) Valve codes

The instrument has 8 electrical programmable outputs (24V DC / 100 mA maximum) of which 4 may be reserved through the presence of the stamping (valve code 1 internal and external) and external dump (valve code 2 internal and external). These outputs (one or more) may be assigned to program numbers. They are generally used to select the valves in a sequence of cycles. The desired outputs can be activated for each program (see Chapter 1 paragraph 2.2.1.1.).

Associated parameters to be set: External 1, External 2, External 3, External 4, External 5, External 6, Internal 1, Internal 2.

☞ Select the option and adjust settings if necessary.

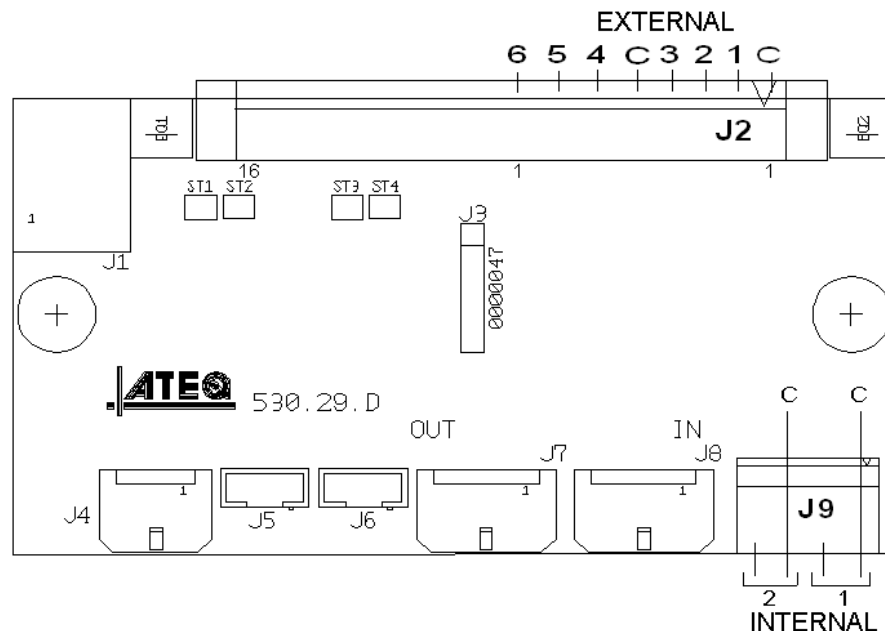

2.1.3. 19) 24V Auxiliary outputs

On the instrument main board there are four programmable electrical outputs (24V DC / 100 mA maximum, outputs).

Unlike the **valve code** outputs, the **auxiliary outputs** reserved for a pneumatic function are identified by the name of the function: stamping, automatic connector, etc. When they are free and available for the operator to use they are called: auxiliary and the position number.

Associated parameters to be adjusted: Auxiliary 1, Auxiliary 2, Auxiliary 3, Auxiliary 4.

☞ Select the option and enter settings if necessary.

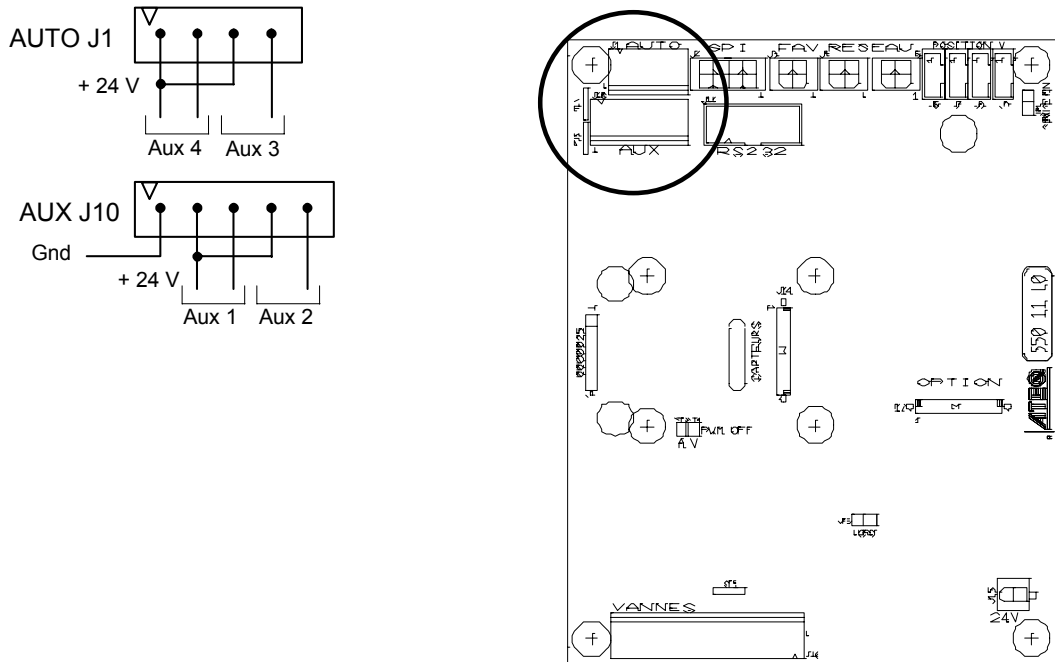

2.1.3. 20) Mini valve

This function is dedicated to applications for small volume parts (below 10 cm³), and has a base time of 0.01 s instead of 0.1 s.

Programming for the **ATEQ D520** mini valve is identical to that for the standard **ATEQ D520**.

Associated parameters to be set: A-Z Diff (Differential Auto-zero). This time can be reduced as long as the values obtained are stable and repeatable.

☞ Select the option and adjust settings if necessary.

2.1.3. 21) No negative

The **"No negative"** function allows to reset the display of the measurement when the flow goes to the negative, in this case, the display of the flow comes to 0 (zero).

This function is useful in the case of we don't want to give the information of a negative flow to the operator (display) or to a PLC connected to the instrument.

☞ Select the option and adjust settings if necessary.

2.1.3. 22) Stamping function

This option is used to activate a pneumatic output which marks the part (for example using a pneumatic cylinder).

Parameters can be set for the conditions and duration of marking.





This option requires two electrical outputs:

- ✓ an internal one for the internal cabling on the pneumatic output,
- ✓ an external one for "customer" cabling

One of the pneumatic outputs on the automatic connectors is used.

The output is activated at the end of test time for the programmed hold time.

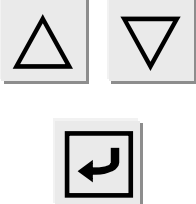
Use the following procedure to use the inking function.

<p>First, in the CONFIGURATION menu, confirm the STAMPING function.</p>		<pre> CONF/EXTENDED MENU FILL MODE : Yes AUTO CONNECT : Yes STAMPING : Yes </pre>
<p>In the program's PARAMETERS/FUNCTIONS menu, confirm the STAMPING function.</p>		<pre> PARAM/Pr001/FUNCTION AUTO CONNECT : No STAMPING : Yes MINI-VALVE : Yes </pre>
<p>Set the inking hold value (can be set between 0 and 650 seconds).</p>		<pre> Pr001/FUNCT/STAMPING MAINTAIN : 00.5 s ALL : No OK : Yes </pre>
<p>Then select the inking conditions from those offered.</p>		<pre> Pr001/FONCT/STAMPING MAINTAIN : 00.5 s ALL : Non OK : Owi </pre>



When the instrument possesses this option, the internal and external valve codes 1 are no longer available.

2.1.3. 23) Cycle end

This function allows the choosing of a different cycle end depending on the configuration of the instrument (connection to a PLC or robot...).

a) Relay sequencing depending the End of Cycle

In order to interface the **ATEQ D520** with its environment (PLC, PC ...), the timing charts below give the sequence for the electrical outputs (relay board on J8 connector) and pneumatics (automatic connectors) according to the commands entered on the front panel or on the J8 connector (START, RESET).

Legend	
A	Coupling time for automatic connector A
B	Coupling time for automatic connector B
AZ	Piezo auto-zero time.
F	Fill time
S	Stabilization time
#	Undetermined time between the end of the programmed test time and the pressing of the RESET  key
T	Test time
D	Dump time
START	Press on the start  key on the front panel or on pins 2-3 of the J3 connector.
RESET	Press on the reset  key on the front panel or on pins 1-2 of the J3 connector.
Automatic connector	Active (high level): the pneumatic output is active (air exiting) Inactive (low level): the pneumatic output is inactive (absence of air)
POK or PNOK	Good part or bad part relay on the J3 connector.
EoC	End of Cycle relay on the J3 connector
t mini	Minimum time for the taking into account of an input, 500 ms on the J8 connector of a central module and 50 ms on the J3 connector of an instrument.

 **Actual times are not those displayed but those on the print-out.**

b) "Automatic RESET" cycle end

If the part is OK, at the beginning of the test time, the good part relay is activated until the following test cycle. After the dump time, the end of cycle relay is activated (or after the coupling time B if it is present).

If the part is fail, the fail part relay is activated as soon as the test is completed. The instrument sends a cycle end signal. A new cycle can then be launched.

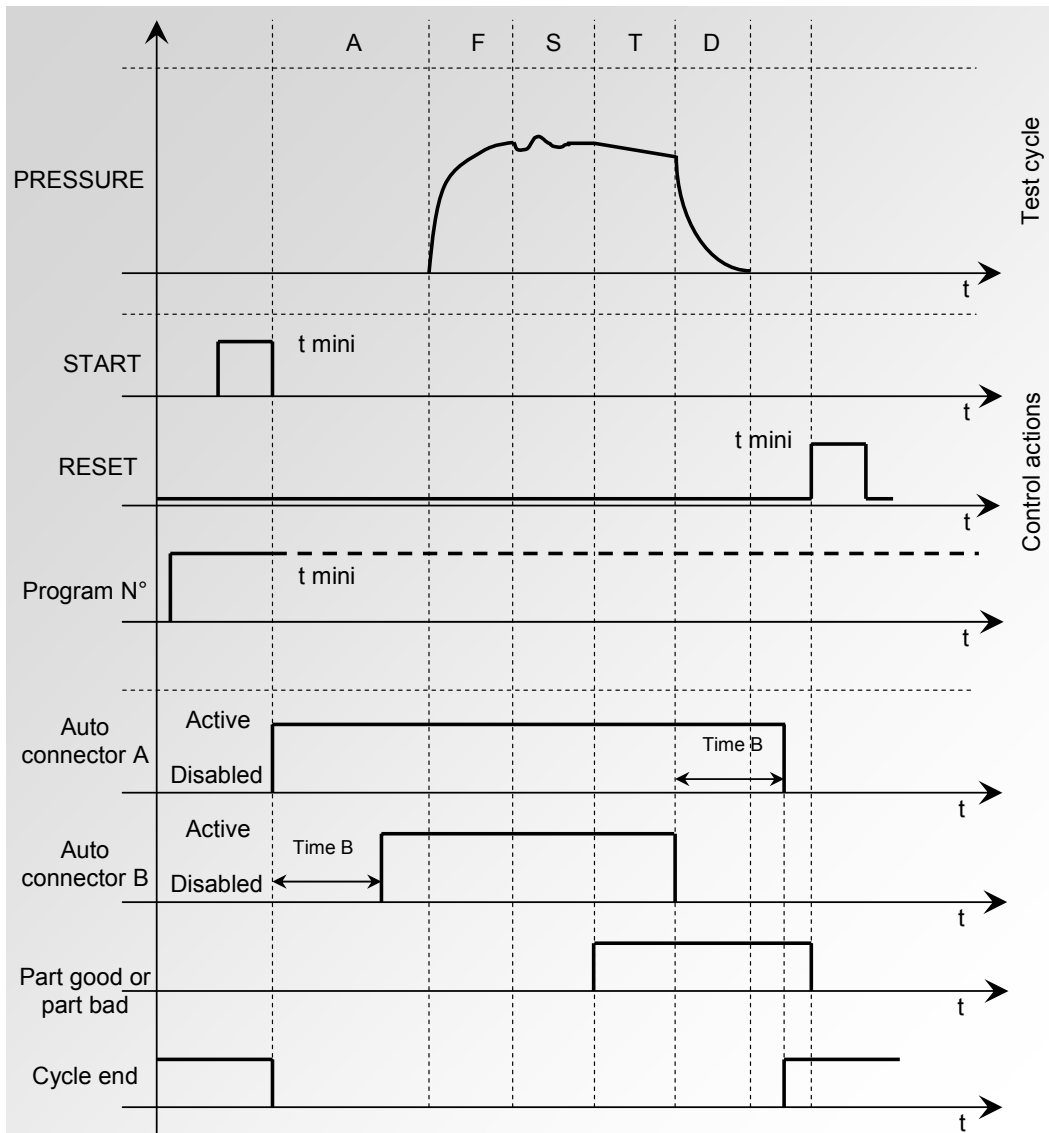

The active program is the one selected before starting up. It remains active even if the program inputs on the connector are no longer activated. This selection can only be modified during the inter cycle period.

To return to program 1, when a cycle is not in progress, press any of the program selection inputs.

c) Stopping the cycle with the RESET key

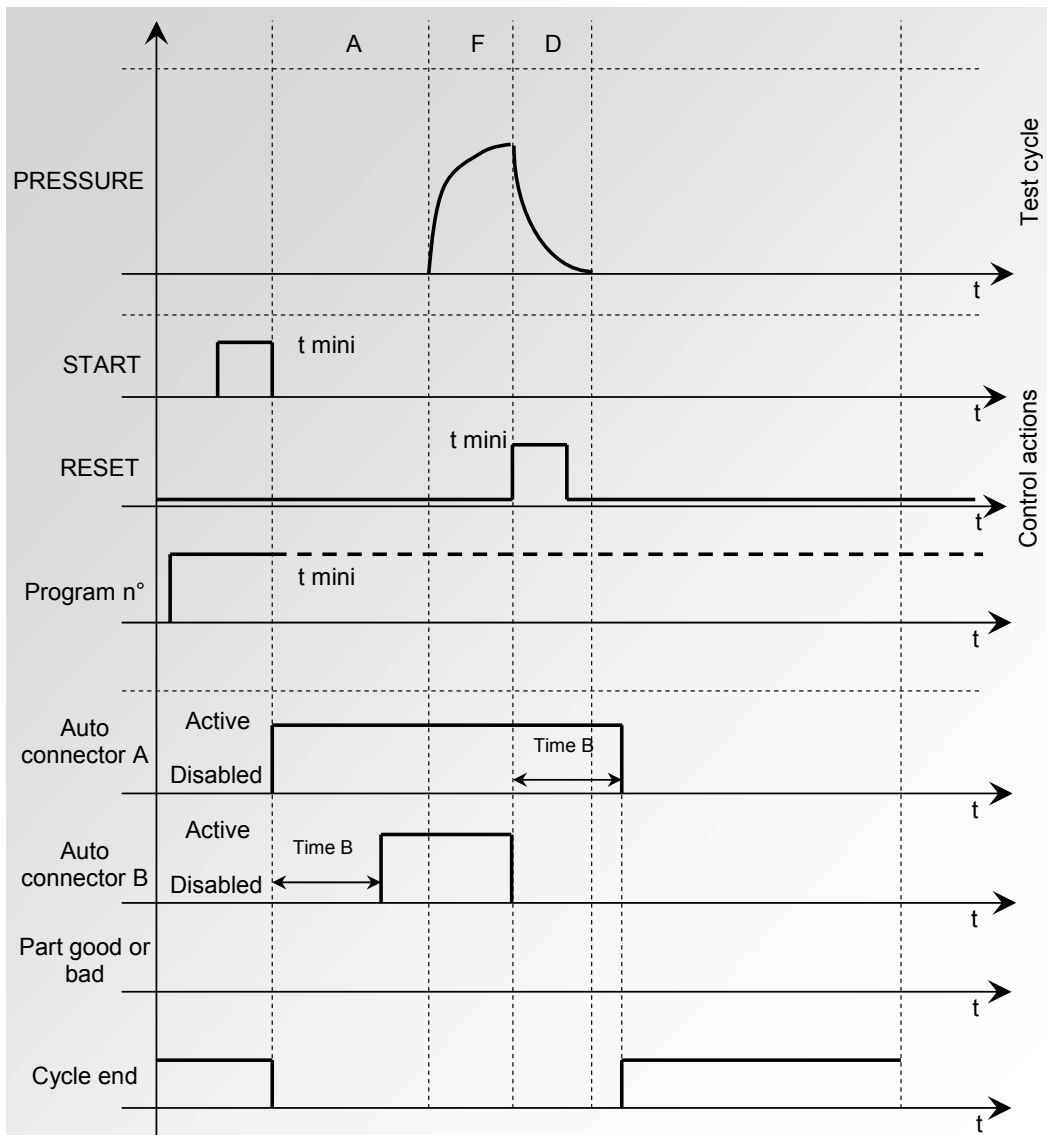

The active program is the one selected before starting up. It remains active even if the program inputs on the connector are no longer activated. This selection can only be modified during the inter cycle period.

To return to program 1, when a cycle is not in progress, press any of the program selection inputs.

d) End of cycle and "Dump + Reset" (automatic dump)

If the part is OK, at the beginning of the test time, the pass part relay is activated and stays activated until the start of the next cycle.

At the end of the dump time, the end of cycle relay is activated (or after the coupling time B if it is present).

If the part is fail, at the beginning of the test time, the fail part relay is activated until the end of the cycle, the dump phase is carried out. The end of the cycle is obtained by pressing on the **Reset** key or by activating the Reset input.

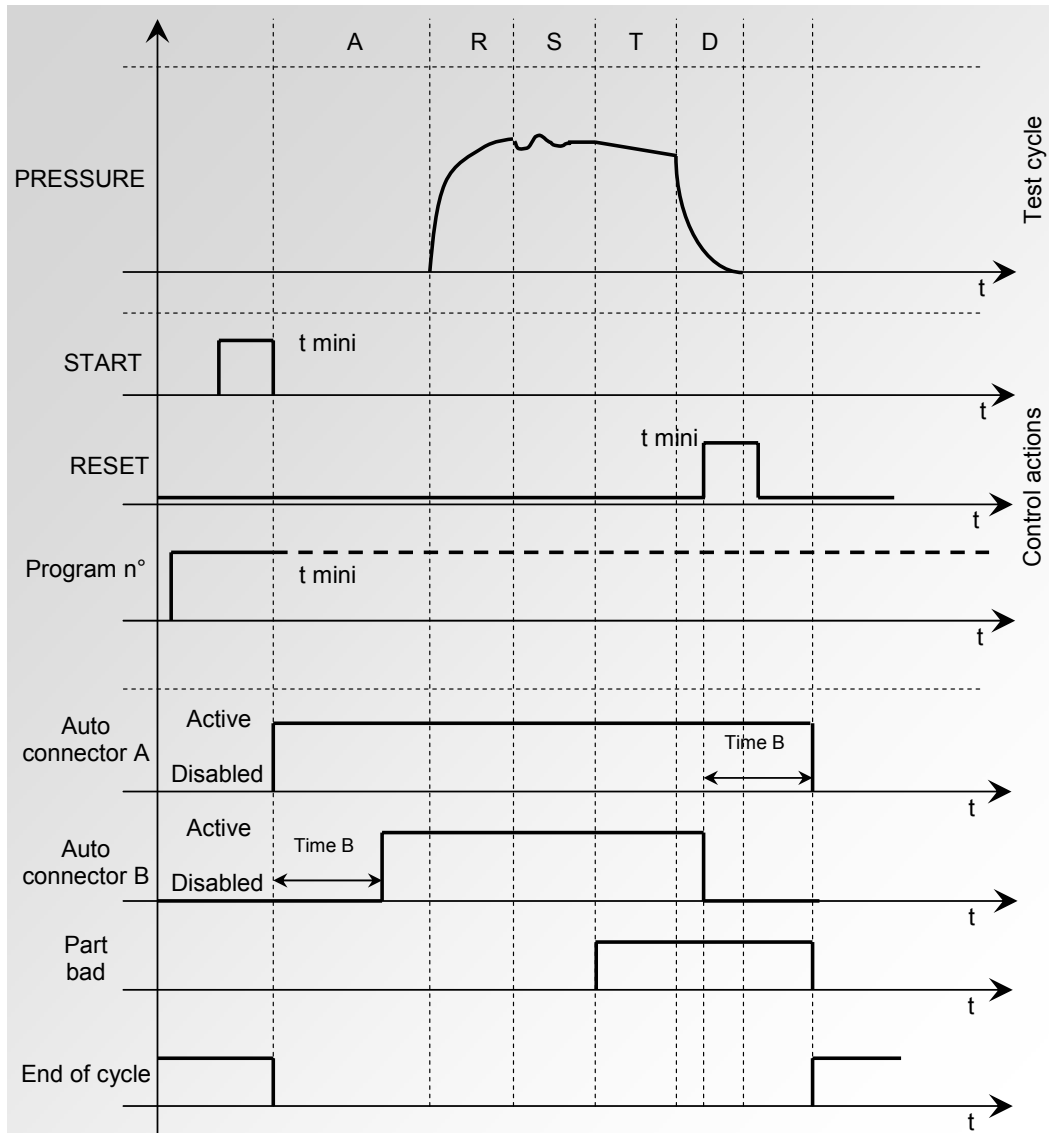

The active program is the one selected before starting up. It remains active even if the program inputs on the connector are no longer activated. This selection can only be modified during the inter cycle period.

To return to program 1, when a cycle is not in progress, press any of the program selection inputs.

e) End of Cycle "FILL"

If the part is OK, the pass part relay is activated at the end of the test time until the start of the following cycle.

As soon as the test time is finished, if the part is fail the fail part relay stays activated.

In infinite fill mode, the instrument awaits an operator or PLC initiated reset to start the dump time and send an end of cycle signal (or after the coupling time B if it is present).

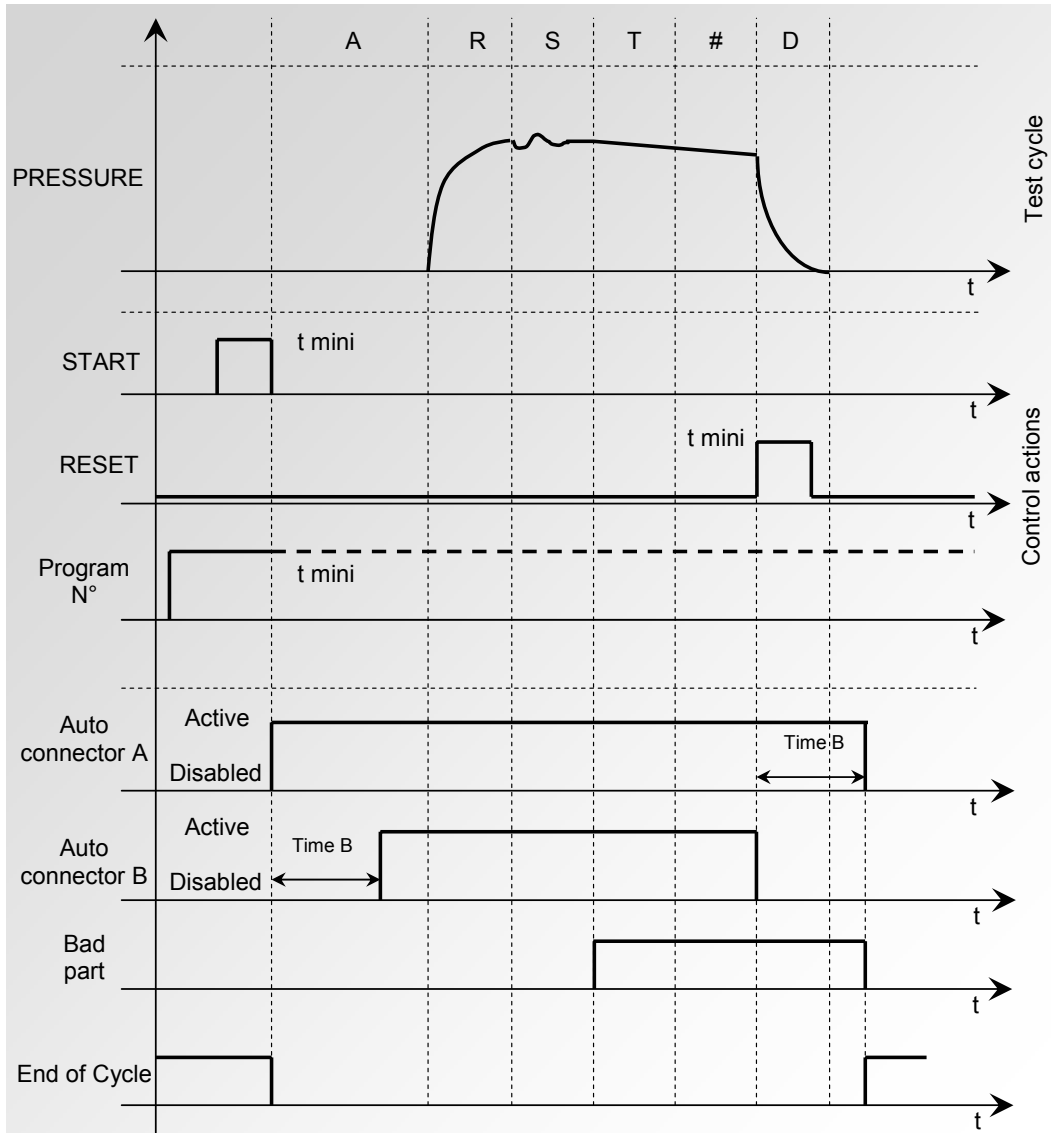

2.1.3. 24) Sign

The **SIGN** function enables the inversion of the sign (positive or negative) of the measurement result. This function is useful in the event of vacuum or recovery measurement as it allows the display of a positive leak result.

<p>The Sign function (when it is validated) changes the sign for the leak value.</p>		<pre>PARAM/Pf001/FUNCTION TEMP. CORR. 1 : Yes INDIRECT : Yes SIGN : Yes</pre>
---	---	---

Example: if the result is -004 Pa, then the display will be 004 Pa.

2.1.3. 25) Gas (option)

This function allows calculating the flow measurement for a gas different from that commonly used by the apparatus (air).

The available parameters in the instruments are for the following gas:

- Nitrogen (N₂),
- Natural gas (CH₄, Methane G20),
- Propane gas (C₃H₈, G31),
- Butane gas (C₄H₁₀, G30),
- G110,
- "User" gas (the parameters have to be indicated, consult us).

The full scale of flow varies according to the employed gas:

Air full scale l/h	5	30	150	500	1500	4000	10000
Nitrogen (N₂)	4,979	29,87	149,4	497,9	1494	3983	9958
Methane (CH₄) G20 natural gas	5,325	31,95	159,7	532,5	1597	4260	10649
Propane (C₃H₈) G31	1,100	6,60	33,0	110,0	330	880	2200
Butane (C₄H₁₀) G30	1,023	6,14	30,7	102,3	307	818	2045
G110	7,165	42,99	214,9	716,5	2149	5732	14329

The "gas" function is an option asked at the order of the instrument.

NB: the fitting and the calibration of the instrument are established with air. A calibration with a specific gas can be carried out on request.



 Select the option and adjust settings if necessary.



This type of instrument has a specific hardware configuration, a connection allows the rejection of a small quantity of gas at each piezo auto reset. The precautions related to the use of a flammable gas are to be applied to the working station.





2.1.3. 26) Display

The "DISPLAY" function allows modify the result display format, this to put the comma and display the decimal number following the user preferences. Example: X.XXX, XX.XX, XXX.X or XXXX.











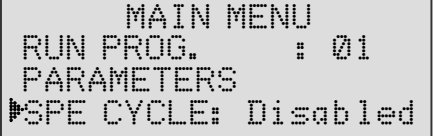

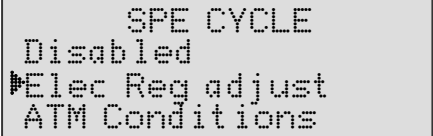
<p>First check or validate the "Display" function into the CONFIGURATION menu.</p>		<pre>MENU / CONFI / EXTENDED SIGN : No F. S. DAC : No ▶DISPLAY : Yes</pre>
<p>Then in the test program parameters, choose the display format by using the UP and DOWN keys.</p>		<pre>PARAM / Pr001 / FUNCTION STD. COND : No FILL MODE : No DISPLAY : X.XXX <</pre>

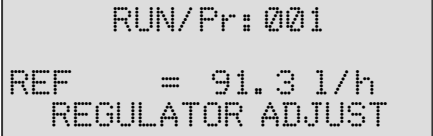
2.1.3. 27) Flow regulation (Option)

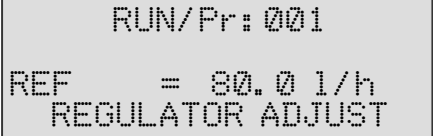
The flow regulation function allows to automatically adjusting the pressure following a flow instruction. This option is available only with an instrument fitted with an electronic regulator.

<p>It's necessary to deactivate (No) the "Regulator learn" function into the "CONFIGURATION" menu.</p>		<pre>MAIN / CONFIGURATION READY STATUS : No BARGRAPH : No ▶REGUL LEARN : No</pre>
<p>Validate (Yes) the "FLOW REG." function in the "CONFIGURATION/ Extended Menus" menu.</p>		<pre>CONFI / EXTENDED MENUS F. S. DAC : No DISPLAY : No ▶FLOW REG. : Yes</pre>
<p>In the test program parameters menu, validate (Yes) the "FLOW REG." function.</p>		<pre>PARAM / Pr001 / FUNCTION FILL MODE : No DISPLAY : X.XXX >FLOW REG. : Yes</pre>
<p>In the test program parameters menu, validate (Yes) the "FILL MODE" function.</p>		<pre>PARAM / Pr001 / FUNCTION >FILL MODE : Yes DISPLAY : X.XXX FLOW REG. : Yes</pre>
<p>Then select the "PERCENT" mode in the "FILL MODE" function.</p>		<pre>r001 / FUNCT / FILL MODE >FILL MODE : PERCENT</pre>

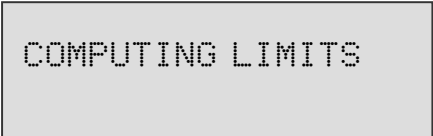
Connect a pass part to the instrument and make the flow instruction adjustment by starting the "Elec Reg Adjust" special cycle.

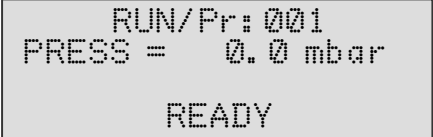
<p>Select the SPE CYCLE menu and validate with ENTER.</p>		
<p>Then select the "Elec Reg adjust" special cycle and validate with ENTER.</p>		
<p>The display confirms that the special cycle is selected.</p>		
<p>Press the START key to launch the special cycle.</p>		
<p>Adjust the flow value by using the UP and DOWN keys.</p>		
<p>Turn the key in the ACCESS position, the message: COMPUTE LIMITS appears on the screen.</p>		
<p>Validate by pressing the ENTREE key, the instrument calculates the flow thresholds (+/- 10% of the adjusted value), the pressure instruction in percent of the full scale and record them into the test program parameters.</p>		
<p>When the flow is adjusted, press on the RESET key to stop the special cycle. Put the key in the LOCK position.</p>		

Note: it's possible to modify manually the flow thresholds calculated by the instrument.

The flow instruction taken in account for the test cycles will be the average of the maximum and the minimum thresholds.

2.2. AUTOMATIC SAVE

This function has for main objective to save the test parameters from the RAM memory of the instrument to its flash memory.

When this function is not validated, each time the key switch is turned from the **ACCESS** to the **LOCKED** mode, the instrument displays **NO PARAMETERS SAVED IN FLASH**. The save operation can be carried out manually in the **SERVICE PARAMETERS** menu.

When the **AUTOMATIC SAVE** function is confirmed with a **YES**, the parameters are saved automatically when the key is turned from the **ACCESS** to the **LOCKED** position.

This function is useful if the parameters in the RAM are accidentally erased. The instrument will then automatically read and restore the flash parameters in the RAM.

2.3. PROGRAM SEQUENCES

2.3.1. Sequences conditions









The sequences allow chaining several different cycles ones after ones, following some the above conditions:

- 16 programs can run into one sequence.
- 32 sequences can be created.
- Built-in 64 programs device.
- A test program can be into several different sequences.
- All the programs in a sequence must have the "Cycling" function validated.
- Run the following program in the sequence by following the cycling conditions validated in the test program.
- If the operator wants, during the test time (infinite or not), if he hits the start key, the sequence jumps to the following test program.
- If the cycling condition is wrong, the sequence stops and the part is declared fail. In all cases, the sequence starts from the beginning.
- A program can be cycled with itself in one sequence, for that, insert it several times.
- The program numbers are not important in the sequences; the program 17 can run before the program 2.
- It's possible to run only one program, for that, create a sequence with only one program.
- It's possible to run the same program several times in one sequence.
- It's not possible to cycling a sequence after another one.
- Some functions are not available when the Sequence mode is activated.

Sequences examples:

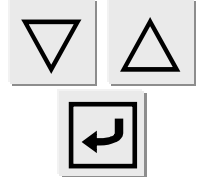
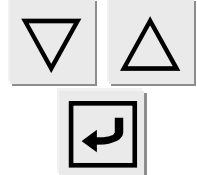
Step	Sequence 01	Sequence 02	Sequence 03	>	Sequence 32
1	Program 1 V	Program 3 V	Program 1 End	>	Program 4 V
2	Program 3 V	Program 2 V			Program 7 V
3	Program 1 End	Program 1 V			Program 2 V
⋮		Program 1 V			Program 4 V
⋮		Program 2 End			Program 3 End
16					

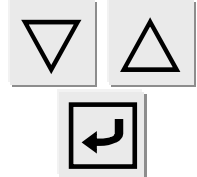



2.3.2. Sequences installation

First, check or validate the SEQUENCE function in the CONFIGURATION menu.		<pre>MENU / CONFIGURATION EXTENDED MENUS AUTO SAVE : Yes SEQUENCE : Yes</pre>
In the main menu, the SEQUENCE function appears, select it and validate it.		<pre>MENU PRINCIPAL RUN SEQ. : SQ01 SEQUENCE PARAMETERS</pre>
Select a first sequence, here the sequence 01 then validate.		<pre>SEQUENCE UTILITY SQ01 SQ02</pre>
In the line " NAME " it's possible to type a sequence name.		<pre>SEQUE/SQ01 NAME : <01> ----- <02> -----</pre>
Then select the first step and validate, by using the UP and DOWN arrows choose the program and validate.		<pre>SEQUE/SQ01 NAME : <01> : Pr01+ <02> : -----</pre>
Select the following step, choose the second program, validate and so on.		<pre>SEQUE/SQ01 NAME : <01> : Pr01+ <02> : Pr03+</pre>
When the sequence is programmed, quit it by pressing the C key.		<pre>SEQUE/SQ01 NAME : <01> : Pr01+ <02> : Pr03+</pre>
In the main menu, select the desired sequence.		<pre>MENU PRINCIPAL RUN SEQ. : SQ01 SEQUENCE PARAMETERS</pre>
Start the sequence by pressing the START CYCLE key.		<pre>SQ01/CYCLE/Pr: 001 PRESS = 30.0 mbar READY</pre>

Note: if the sequence doesn't start or if it stops on a program test, check in this program if the function and cycling conditions are validated.

2.3.3. Sequences utility

The "**UTILITY**" menu allows managing the sequences, as the programs, it allows to make sequences "**copy-paste**", delete the sequence name or totally delete the sequence.

<p>In the "SEQUENCE" menu, select the "UTILITY" menu then validate.</p>	 	<pre> SEQUENCE UTILITY SQ01 SQ02 </pre>
<p>The select the desired command, the procedures are the same as the test parameters program management.</p>	 	<pre> SEQUE/UTILITY COPY : ----- PASTE : ----- DELETE NAME : SQ01 </pre>

2.4. READY STATUS

The function "**Ready status**" allows to determinate the blow mode when the instrument is in the rest (out of test cycle). It's exist three blow modes:

- Blow on the reference circuit (Ref.),
- Blow on the test circuit (Test),
- No blow (Stop).

In the case of installation of electronic regulator in option, the right think to do is to inform the blow pressure instruction.

☞ Select the option and adjust settings if necessary.

2.5. REFERENCE CAL

The "Reference CAL" function, when is validate by "Yes" allows to make appears a "CAL ref" calibration special cycle, thus allowing to calibrate the reference circuit. This is a "super" calibration.

To calibrate the reference circuit, it must connect the "super master" on the test circuit and then select the "CAL ref" special cycle", capture the "super master" characteristics and launch the special cycle.

Thus when the special cycle is finished, the new characteristics are captured in the standard master jet parameters of the reference circuit.

☞ Select the option and adjust settings if necessary.

2.6. BAR GRAPH

This function is only valid if an RC5 remote control or L.E.D. 14 characters display is fitted.

It allows the graphical representation of the flow value in relation to the reject thresholds set.

On the lower scale, the minimum and maximum thresholds in relation to the full scale are displayed.

On the upper scale the flow value is displayed.

The parameters which can be set (30 % 50 % and 70 %) place the maximum threshold to 30 %, 50 % or 70 % of the bar graph. The example below represents a bar graph with a maximum threshold at 50 %:

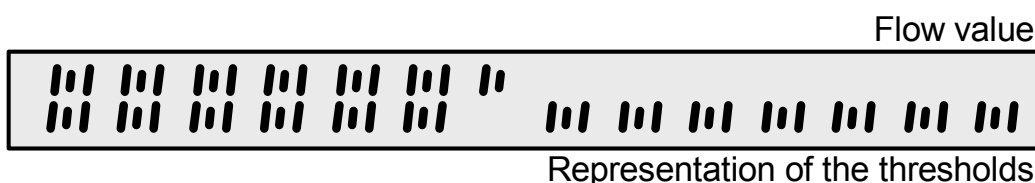

☞ Select the option and adjust settings if necessary.

2.7. HOUR

This function includes a clock (hour, minutes) and an internal calendar (day, month and year).

☞ Select the option and adjust settings if necessary.

2.8. REGULATOR LEARNING

2.8.1. Standard regulator learning

This function is only valid in the event of the installation of a regulator in the instrument.

It enables the determining of the time between two electronic regulator learning cycles. When it is validated by "yes", the frequency (time or minutes) or the number of cycles between two learning cycles is to be determined.

When the frequency or number of cycle values are at zero, the learning request becomes manual, at the operator request by way of special cycle, or by the programmable input 7.

The learning cycle allows the calculation of the three characteristic points of the regulator (points at 20 %, 50 % and 80 % of the maximum pressure which can be supplied by the regulator, value depending on the input air supply pressure).

☞ Select the option and adjust settings if necessary.

2.8.2. Without regulator learning

When the "Regulator learning" is not validated (No) there won't regulator characteristics calculation (points at 20 %, 50 % and 80 %).

In this case two options arise in the "Fill mode" function: the fill mode in "Percent" or "Control". These two types appear in the case of test in "Flow" mode.

2.8.2. 1) "Percent" type

In this mode, it must adjust the pressure instruction in percent of the full scale of the regulator. Example: full scale of the regulator 4 bars, test pressure 1.5 bars then the percentage will be 37.5 %.

2.8.2. 2) "Control" type

In this mode, it must adjust the hoped pressure instruction (real value in the configured measurement unity).

The electronic regulator is correcting two times the pressure rise ramp during the fill. This function allows making a correction of the pressure instruction according the flow. When this correction is too important, an alarm "< Min. Pressure" is activated.

During the stabilization and test phases, no instruction correction is realized.

2.9. RS232

2.9.1. C540/580

This function enables the configuration of the instrument so that it may be supervised by an ATEQ central module.

☞ Select the option and enter settings if necessary.

2.9.2. Printer

This function is used to configure the instrument so that the data relating to the programs (parameters) and the test results can be printed. When the option is activated (YES), the test results are automatically printed each time a cycle is started.

☞ Select the option and enter settings if necessary.

2.9.2. 1) RS parameters

These parameters are used to configure the instrument for dialogue with the printer.

Associated parameters to be set: Speed (bit rate transmission), stop bit, data bit number, parity.

☞ Select the option and enter settings if necessary.

2.9.2. 2) Frame

This function allows the configuration of the results frame.

Associated parameters to be adjusted: **PRESSURE** (Display of the test pressure or not), **Personalization** (Display of the program name when there is one), **Timekeeper** (printing of the date and the time), **Before result** (number of lines before the result), **After result** (number of lines after the result), **Inter Line** (space between each line).

2.9.2. 3) Format of the frame

The results frame fits on 40 columns.

a) Example for a good test result

1 2 3 4 5 6 7 8 9 10 11 12 13 14 15 16 17 18 19 20 21 22 23 24 25 26 27 28 29 30 31 32 33 34 35 36 37 38 39 40

```
< 0 1 > : ( P B ) : 1 0 7 . 6 m l / s
```

Details of the frame:

Columns	Characters
1	<
2-3	Number indicating the program number
4	>
5	:
6	(
7 – 8	2 letter indicating OK for a good part, F+ for a bad part with a high flow, F- for a bad part with a low flow.
9)
10	:
11	SPACE
12 – 16	5 numbers indicating the value of the leak
17	SPACE
18 > XX	3 to 6 letters indicating the unit

b) Example for a test result with pressure

1 2 3 4 5 6 7 8 9 10 11 12 13 14 15 16 17 18 19 20 21 22 23 24 25 26 27 28 29 30 31 32 33 34 35 36 37 38 39 40

```
< 0 1 > : 1 8 . 8 m b a r : ( O K ) : 1 0 2 . 1 m l / s
```

c) Example for a test result with timekeeping

1 2 3 4 5 6 7 8 9 10 11 12 13 14 15 16 17 18 19 20 21 22 23 24 25 26 27 28 29 30 31 32 33 34 35 36 37 38 39 40

```
< 0 1 > : 1 0 / 0 4 / 2 0 0 3 1 6 : 0 2 : 4 0
```

```
< 0 1 > : 1 8 . 5 m b a r : ( O K ) : 1 0 1 . 8 m l / s
```

d) Example for a test with an error

1 2 3 4 5 6 7 8 9 10 11 12 13 14 15 16 17 18 19 20 21 22 23 24 25 26 27 28 29 30 31 32 33 34 35 36 37 38 39 40

```
< 0 1 > : ( A L ) : F S S c . p i e z o
```

```
< 0 1 > : ( A L ) : P R E S S U R E L O W
```

```
< 0 1 > : ( A L ) : P R E S S U R E H I G H
```

Details of the frame:

Columns	Characters
1	<
2-3	Number indicating the program number
4	>
5	:
6	(
7 – 8	2 letters AL for ALARM
9)
10	:
11 > XX	Error text corresponding to the error

2.9.3. Send conditions

With this function you can choose which data is to be printed on the results sheet.

Associated parameters to be set: **ALL** (all test results), **OK** (number of good parts), **MAX** (high flow parts), **MIN** (low flow parts), **WARN.** (number of times the alarm has been triggered), **PRESS DEF.** (number of times pressure was incorrect), **RECUPERABLE** (number of recoverable parts).

 Select the option and enter settings if necessary.

2.9.4. Exportation

This function can be used to create and send a special results frame which can be processed by a PC using Microsoft Excel.

This frame is of the same type as the print parameters frame except that the different character strings follow each other and are separated by a punctuation mark which enables the various boxes to be entered automatically in Microsoft Excel.

This frame is operated by connecting a computer to the instrument's RS232 link.

 Select the option and enter settings if necessary.

2.9.5. Print the parameters

By validating this function, the test parameters of the programs activated on the instrument are instantly printed.

2.9.5. 1) Parameter printout frame example

1	2	3	4	5	6	7	8	9	10	11	12	13	14	15	16	17	18	19	20	21	22	23	24	25	26	27	28	29	30	31	32	33	34	35	36	37	38	39	40			
V	e	r	s	i	o	n		0	1	.	1	0	h																													
1	:	0	/	0	4	/	2	0	0	3	:	1	5	:	3	2	:	3	7																							
P	r		0	1																																						
T	:	Y	:	P	:	E	:		:	D	:	I	:	R	:	E	:	C	:	F	:	L	:	O	:	W																
C	:	O	:	U	:	P	:	L	:	I	:	N	:	G	:	A	:	:	0	:	0	:	.	:	0	:	s															
F	:	:	:	I	:	:	:	L	:	:	:	:	:	:	:	:	:	:	0	:	2	:	.	:	0	:	s															
S	:	:	:	T	:	:	:	A	:	:	:	:	:	:	:	:	:	:	0	:	2	:	.	:	0	:	s															
T	:	:	:	E	:	:	:	S	:	:	:	:	:	:	:	:	:	:	0	:	2	:	.	:	5	:	s															
M	:	:	:	a	:	:	:	x	:	:	:	:	:	:	:	:	:	:	:	3	:	:	:	:	:	:	0	:	.	:	0											
M	:	:	:	i	:	:	:	n	:	:	:	:	:	:	:	:	:	:	:	:	1	:	:	:	:	:	:	0	:	.	:	0										
R	:	:	:	E	:	:	:	J	:	:	:	:	:	:	:	:	:	:	:	:	:	:	:	:	:	:	:	:	:	:	:	:	:	:	:	:	:	:	:	:	:	:
R	:	:	:	E	:	:	:	J	:	:	:	:	:	:	:	:	:	:	:	:	:	:	:	:	:	:	:	:	:	:	:	:	:	:	:	:	:	:	:	:	:	:

Note: The "PROGRAM NAME" characters are printed when a program name has been set in the parameters.

2.10. RS485

This function enables the configuration of the RS485 output to a C540 central or F580 when the instrument is installed in a network.

☞ Select the option and enter settings if necessary.

2.11. MODBUS

This function enables the configuration of the Modbus link when the instrument is installed in this type of network. The frame parameters, RS parameters (speed, serial port) must be entered.

☞ Select the option and enter settings if necessary.

2.12. SECURITY

This function deactivates the **START** key on the instrument front panel. Programs can only be started from the instrument inputs (J3 connector).

☞ Select the option and enter settings if necessary.







2.13. LIGHTING THE SCREEN

Screen illumination can be programmed and modified. The lighting can be adjusted according to the ambient conditions or the user's choice.

There are three lighting modes:

- ✓ **continuous** mode, display screen permanently lit whatever the conditions
- ✓ **manual** mode, the screen remains lit for 20 minutes and if the keyboard has not been used by the end of this period the screen shuts down and only relights when the keyboard is touched again.
- ✓ **automatic** mode, which is identical to manual mode, with illumination of the screen also if an action is carried out from the external inputs (rear connectors)

Using these three modes, the lighting intensity of the screen can be programmed from 00 (screen off) to 07 (maximum lighting intensity).

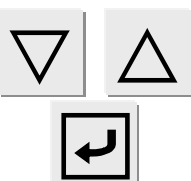
<p>In the main menu, position the cursor by the CONFIGURATION menu then confirm by pressing ENTER.</p>		<pre> MAIN MENU PARAMETERS SPE CYCLE: Disabled ▶CONFIGURATION </pre>
<p>Move the cursor down until it is in front of the LIGHT menu then confirm by pressing ENTER.</p>		<pre> CONFIGURATION RS485 : C540/580 SECURITY : No ▶LIGHT </pre>
<p>Place the cursor in front of MODE to choose the required lighting mode and confirm using ENTER.</p>		<pre> MAIN/CONFI/LIGHT ▶MODE : CONT INTENSITY: 07 </pre>
<p>Select the lighting mode and confirm using ENTER.</p>		<pre> IN/CONFI/LIGHT/MODE ▶CONT MANUAL AUTO </pre>
<p>To return to the previous menu, press the C button once.</p>		<pre> MAIN/CONFI/LIGHT ▶MODE : CONT INTENSITY: 07 </pre>
<p>To select the lighting intensity for the display, place the cursor in front of the INTENSITY menu and confirm using ENTER.</p>		<pre> MAIN/CONFI/LIGHT MODE : CONT ▶INTENSITY: 07 </pre>
<p>Then select the lighting intensity from 00 (off) to 07 (maximum) and the new lighting intensity will be applied after ENTER is pressed.</p>		<pre> MAIN/CONFI/LIGHT MODE : CONT INTENSITY: 04 </pre>

2.14. BAR CODE OPTION

2.14.1. Definition

The “**Bar code**” option enables to install a bar code reader on a second specific **RS232** connector of the **5th series ATEQ** instruments.

It enables on reading of the code to select a test program and eventually to launch the test of control (if the option is validated).

The quantity of characters read by the reader should not exceed **22**. Beyond the unit will not take into account the character string (bar code string).

This option is valid for the units starting from the last version ATEQ devices.

2.14.2. Communication parameters configuration



The **Bar Code reader** must be set with the following communication parameters:

- **9600** bauds,
- **7** bits,
- **1** stop,
- Parity **even**.

The communication parameters of the **ATEQ** devices are the same by default and fixed, it's not provide to change it.

2.14.3. Function activation

Warning: each change of parameters or configuration will reset all the learning. It will be necessary to learning again all the bar codes for each programs.

<p>From the main menu, put the cursor in front of CONFIGURATION.</p>		<pre> MAIN MENU SPE CYCLE : Disable CONFIGURATION RESULTS </pre>
<p>Select the BAR CODE function and validate by YES.</p>		<pre> CONFIGURATION BARCODE : Yes SECURITY : No LIGHT </pre>
<p>Then appears the parameters of reading of the bars codes, which it is advisable to inform.</p>		<pre> CONF/ BARCODE Pr. Select : No Reset EOC : No </pre>

The "**Select Pr.**" parameter enables to select the paired program to the bar code number. When the bar code is learned, when flashed, the corresponding program will be selected as the active program.



2.14.4. Program selection function not validated

If the "Select Pr." Function is not validated (No) the function "Reset EOC" is displayed.

<p>Validate the "Reset EOC". Function (Yes).</p>		<pre> CONF I / BARCODE Pr. Select : No Reset EOC : Yes </pre>
--	---	---

- "Reset EOC" Function not validated (No):** the flashed bar code is recorded in the device memory, and is used for the all serial product until a new number is flashed. This number will be sent on the device output frame or on the print output.
- "Reset EOC" Function validated (Yes):** the flashed bar code is recorded in the device memory; it will be used only for the next test cycle and will be deleted at the end of cycle. This number will be sent on the output frame or on the print output for the current cycle. If no number is flashed for the next cycle, no number will appears or printed (blank).

2.14.5. Program selection function validated



<p>Validate the "Select Pr." function (Yes).</p>		<pre> CONF I / BARCODE Pr. Select : Yes First char : 05 Char Number : 10 </pre>
<p>The reading parameters for the bar code are displayed, that should be informed.</p>		<pre> CONF I G / BAR CODE Select Pr. : Yes First char : 05 Char Number : 10 </pre>

The parameter "First character" corresponds to the position of first character to take in account in the total string of characters.

The parameter "Char number" corresponds to the quantity of characters (or the length of the chain) to take in account.

The sum of the two captured parameters must be lower or equal to the total quantity of characters contained in the chain plus 1.

$$\sum \text{Parameters} \leq \text{Total quantity of characters} + 1 \leq 22$$

<p>Adjust the values of the parameters using the keys high and low, then validate with the ENTER key.</p>	 	<pre> CONF I G / BAR CODE Select Pr. : Yes First char : 05 Char Number : 10 </pre>
--	---	--

Example: the program will be selected if the unit reads the character chain:



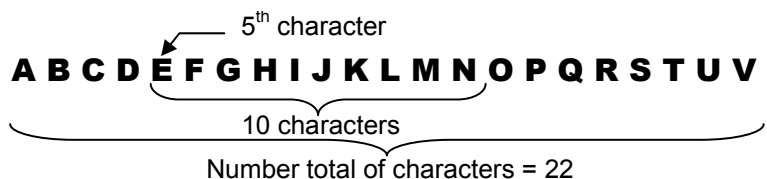

E F G H I J K L M N.







If a same characters string is on several programs, the program with the smallest number will be selected the others will be ignored.

2.14.6. Parameter setting of the strings (LEARNING)

The characters string learning will be done from the special cycles.

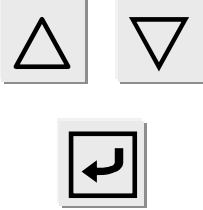
<p>First, check or validate in the CONFIGURATION menu the BAR CODES function (Yes).</p>		<pre> CONFIGURATION ▶BARCODE : Yes SECURITY : No LIGHT </pre>
<p>Back to the main menu, and select the SPE CYCLE menu.</p>		<pre> MAIN MENU ▶SPE CYCLE: None CONFIGURATION SERVICE </pre>
<p>Then go to the BAR CODES function and validate by ENTER.</p>		<pre> SPE CYCLES Infinite fill Auto zero ▶BAR CODE </pre>
<p>The unit requires the number of the test program corresponding to the character chain which will be flashed, validate by ENTER.</p>		<pre> MAIN / BARCODE Pr. Select : 01 ◀ </pre>
<p>The display confirms that the BAR CODE special cycle is selected.</p>		<pre> MAIN MENU RUN PROG. : 01 PARAMETERS ▶SPE CYCLE: BARCODE </pre>
<p>Press START to run the special cycle. The device waits for the bar-code (string characters). The paired program number is displayed.</p>		<pre> CYCLE/Pr : 01 Pr. Select : 1 BARCODE </pre>
<p>Then flash the code by using the bar code reader. The captured string is displayed.</p>		<pre> CYCLE/Pr : 01 Pr. Select : 1 123456789001XXXXXXXXX 01 BARCODE </pre>
<p>The code is recorded and the device is ready to run. At each time this character string is flashed, the paired program will be set as active program.</p>		<pre> CYCLE/Pr : 01 PRESS = 185.8 mbar 123456789001XXXXXXXXX READY (OK) </pre>

2.14.7. Program running

<p>From the main menu, select the PARAMETERS menu.</p>		<pre> MAIN MENU RUN PROG. : 01 PARAMETERS SPE CYCLE: none </pre>
<p>Select a program and validate with ENTER.</p>		<pre> PARAMETERS Copy-Paste Pr: 01 LEAK Pr: 02 LEAK </pre>
<p>Then select the FUNCTION menu and validate with ENTER.</p>		<pre> PARAM/Pr001 Test FAIL : 020 Ref. FAIL : 000 FUNCTIONS </pre>
<p>Validate the BAR CODE function (Yes).</p>		<pre> ARAM/Pr001/FUNCTIONS BAR CODE : Yes </pre>
<p>The characters string is displayed under the Num parameter, the AUTO START parameter allows starting automatically the test cycle when the barcode is flashed.</p>		<pre> /Pr001/FUNCT/BARCODE Num : 123456789001X Auto Start : Yes </pre>
<p>If the flashed code is unknown, the "DEF. BARCODE" message is displayed.</p>		<pre> CYCLE/Pr : 01 PRESS = 185.8 mbar DEF. BARCODE READY </pre>

2.15. I/O CONFIGURATION

This menu is used to configure programmable input 7 on connector J3 on the 16-program input/output board.

See the Chapter 1, paragraph 2.2.1.5) "Connector J3 (Inputs/Outputs) programmable input".







Note: the manual auto zero maintains the instrument in auto zero mode as long as the input is not activated.

2.16. REMOTE CONTROL

When an 8 functions console is fitted to the instrument, the remote control menu allows the programming of special menu shortcuts and the use of a “**Start**” function on the four function buttons (F1, F2, F3 or F4) available on this remote control.

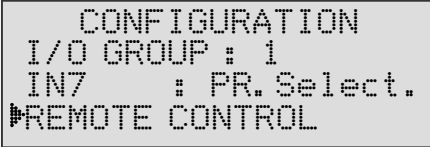
This function is only available when a console is connected to the instrument which will automatically detect its presence.

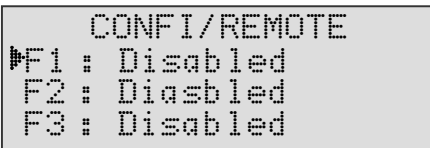
The “**Start**” function enables the configuration of a function key in such a way as to simulate a console with a two handed control (cycle start with a function key and a cycle start key pressed simultaneously).

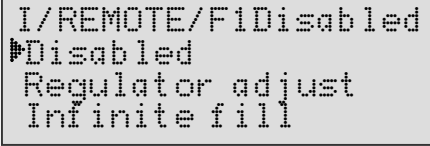
<p>In the main menu, place the cursor in front of the CONFIGURATION menu, then confirm with the ENTER key.</p>		 <pre> MAIN MENU PARAMETERS SPE CYCLE: Disabled ▶CONFIGURATION </pre>
<p>The, in the CONFIGURATION menu, place the cursor in front of REMOTE CONTROL and confirm</p>		 <pre> CONFIGURATION I/O GROUP : 1 IN7 : PR. Select. ▶REMOTE CONTROL </pre>
<p>Select the key to be programmed, F1 to F4, then confirm.</p>		 <pre> CONF/REMOTE ▶F1 : Disabled F2 : Disabled F3 : Disabled </pre>
<p>In the special menus choose the function to be associated to the key.</p>		 <pre> I/REMOTE/F1Disabled ▶Disabled Regulator adjust Infinite fill </pre>

Notes: when a function is programmed on a key "F", it is deleted from the menu to not be installed on another "F" key.

The special cycle appears and is programmable if it has been activated in at least one of the test programs.

The programmed special cycle appears on the same key for all the programs, it will be inactive if it is disabled in the current program.

3. SPECIAL CYCLES MENU

3.1. SPECIAL CYCLES AVAILABLE

The following list shows all the special cycles which are possible: those available will vary depending on what is checked in the extended menus and according to the optional extras requested at the time of manufacture of the instrument.





Special cycle	Function
✓ Inactive:	No special cycle is selected.
✓ Regulator adjustment:	Cycle allowing the adjustment of regulator number 1 (generally on the rear panel).
✓ Electronic regulator learning (if installed):	Cycle allowing the adjustment of points to the different pressure values of the electronic regulator, 20 %, 50 % and 80 %.
✓ Infinite fill:	Cycle allowing the infinite pressurization of the test part.
✓ Reference calibration:	"Super" calibration special cycle, allowing the reference circuit calibration.
✓ Piezo auto zero:	Cycle allowing the carrying out of a forced reset of the piezo sensor and the electronic regulator.
✓ CAL learning:	This cycle enables the carrying out of a learning cycle in calibrated mode on a calibrated leak for which the values are known.
✓ CAL check:	This cycle enables a checking of the calibration of the calibrated mode (refer to previous element) within a tolerance determined through percentage thresholds.
✓ ATR Learning:	This cycle allows the entering of ATR parameters when they are not known, to be done after each instrument start up, or after a long period without test cycle.
✓ Atmospheric conditions:	This cycle allows the display of the ambient atmospheric, pressure and temperature conditions (the temperature is taken inside the instrument).

To run a special cycle, select it in the "special cycles" menu, then press the 

button. To stop it, press the  button. In some cycles the stop is automatic.

3.2. REGULATOR

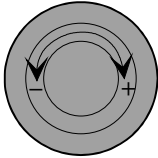
This special cycle enables the main regulator pressure to be set.



<p>Position the cursor in front of SPE CYCLE and confirm using the ENTER key.</p>		<pre> MAIN MENU RUN PROG. : 001 PARAMETERS SPE CYCLE: Disabled </pre>
<p>Next, position the cursor in front of Regulator adjust and confirm using the ENTER key.</p>		<pre> SPE CYCLE Disabled Regulator adjust. ATM conditions </pre>
<p>The display confirms that the special cycle has been selected.</p>		<pre> MAIN MENU RUN PROG. : 001 PARAMETERS SPE CYCLE : Regul </pre>
<p>Press the START key to start the special cycle.</p>		<pre> CYCLE/Pr : 001 PRESS = 355.5 mbar REGULATOR ADJUST </pre>
<p>Adjust the value of the pressure with the regulator.</p>		<pre> CYCLE/Pr : 001 PRESS = 500.0 mbar REGULATOR ADJUST </pre>
<p>In case of electronic regulator (option) adjust the pressure by using the UP and DOWN keys.</p>		<pre> CYCLE/Pr : 001 PRESS = 500.0 mbar REGULATOR ADJUST </pre>
<p>Once the pressure is adjusted, press the RESET key to stop the special cycle.</p>		<pre> CYCLE/Pr : 001 PRESS = 0.000 bar READY </pre>

3.3. CALCULATION OF THE AUTOMATIC THRESHOLDS

This function enables the programming of the monitoring thresholds for the maximum and minimum pressure in relation to the adjustment of the chosen regulator.

The values of the automatically calculated thresholds are of plus or minus 20 % of the value measured.

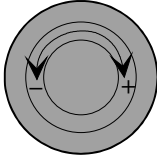
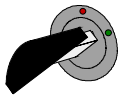
The calculation and the automatic editing of the thresholds is done on the active program.

Confirm the REGULATOR ADJUST special cycle.		<pre> MAIN MENU RUN PROG. : 001 PARAMETERS SPE CYCLE : Regul. </pre>
Press on the START key to launch a special cycle.		<pre> CYCLE/Pr: 001 PRESS = 17 mbar REGULATOR ADJUST </pre>
Eventually adjust the test pressure with the regulator handle or with the UP and DOWN keys if fitted with an electronic regulator (option).		<pre> CYCLE/Pr: 001 PRESS = 20 mbar COMPUTE LIMITS REGULATOR ADJUST </pre>
At this moment, when the key is turned to the ACCESS position, the question: COMPUTE LIMITS appears on the screen.		<pre> CYCLE/Pr: 001 PRESS = 20 mbar REGULATOR ADJUST </pre>
Confirm the calculation with the ENTER key, the instrument computes the thresholds and enters them in the program parameters cycle.		<pre> COMPUTING LIMITS </pre>
When the operation is finished, press on the RESET key to stop the special cycle.		<pre> CYCLE/Pr: 001 PRESS = 20 mbar READY </pre>

Note: in the event of vacuum tests, the negative pressure thresholds keep their mathematical "order".

PRESSURE MEASUREMENT

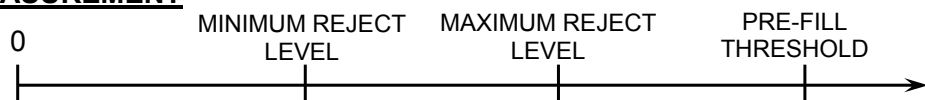



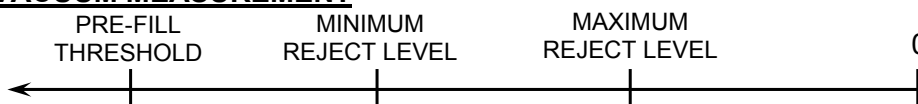

VACUUM MEASUREMENT



3.4. INFINITE FILL

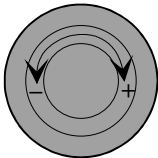

This function is validated when an optional shut off valve is installed in the instrument. This valve allows the stopping of the flow of air (or of gas) out of the cycle.

The infinite fill allows the opening of this shut off valve, in other words to create a constant flow at the test pressure, allowing the part to be checked and to adjust and fine tune the assembly, etc.

<p>From the main menu, position the cursor in front of the CYCLE SPE title and confirm with the ENTER key.</p>		<pre> MAIN MENU ACTIVE PROG. : 001 PARAMETERS CYCLE SPE: Disabled </pre>
<p>Next, place the cursor in front of Infinite fill and validate with the ENTER key.</p>		<pre> SPE CYCLE Disabled Regulator adjust Infinite fill </pre>
<p>The display confirms that the special cycle is selected.</p>		<pre> MENU PRINCIPAL RUN PROG. : 001 PARAMETERS SPE CYCLE : Inf Fill </pre>
<p>Press on the START key to start the special cycle.</p>		<pre> CYCLE/Pr: 001 PRESS = 20 mbar FILL </pre>
<p>Adjust the value of the test pressure with the regulator handle.</p>		<pre> CYCLE/Pr: 001 PRESS = 20 mbar FILL </pre>
<p>To stop the cycle, press on the RESET key.</p>		<pre> CYCLE/Pr: 001 PRESS = 20 mbar READY </pre>

3.5. PIEZO RESET (AUTO ZERO)

Enables to carry out of a forced auto zero (reset) of the piezo sensor.

<p>In the main menu, place the cursor in front of the SPE. CYCLE option and confirm with the ENTER key.</p>		<pre> MAIN MENU RUN PROG. : 001 PARAMETERS └SPE CYCLE: Disabled </pre>
<p>Next, place the cursor in front of Auto-zero Piezo and confirm with the ENTER key.</p>		<pre> SPE CYCLE Pre-regul. adjust. Infinite fill └Auto-zero Piezo </pre>
<p>The display confirms that the special cycle is selected.</p>		<pre> MAIN MENU RUN PROG. : 001 PARAMETERS └SPE CYCLE: AZ-Piezo </pre>
<p>Press on the START key to start an auto zero cycle.</p>		<pre> RUN/Pr : 001 PRESS = 355.5 mbar AUTO_ZERO </pre>
<p>Once the auto zero is carried out, the cycle will stop.</p>		<pre> RUN/Pr : 001 PRESS = 355.5 mbar READY </pre>

Note: the auto zero is an automatic event which is carried out for each cycle, it enables the initialization of the pressure sensors to the atmospheric pressure.

3.6. MANUAL CALIBRATION

3.6.1. CAL learning (calibration)







If the flow units do not suit the application, it is possible to switch to calibrated mode (manual). For that it is necessary to carry out a learning cycle to make the calibration value correspond to the value of a master leak connected to the instrument.

It is necessary to carry out the learning cycle, either by the special cycle's menu or through input 7 of the J3 connector if programmed for this function, or through a programmed function key on the RC5 console if it is installed.

The first CAL learning cycle must absolutely be carried out through the special cycle's menu, so that a CAL instruction other than 0 can be selected.

On the outputs we obtain:

- **"Pass Part "** and **"Cycle end"** if the instruction is inferior or equal to the reject threshold,
- **"Fail Part "** and **"Cycle end"** if the instruction is superior to the reject threshold.

<p>Confirm with "YES" the "UNIT" function in the "CONFIGURATION/ EXTENDED MENUS" menu.</p>		<pre>MAIN /CONF/EXTENDE CYCLING : Yes AUTO MODE : Yes UNITS : Yes</pre>
<p>Confirm with "YES" the "UNIT" function in the "PARAMETER/FUNCTION" menu of the program.</p>		<pre>PARAM/Pr001/FUNCTION CYCLING : No AUTO MODE : No UNITS : Yes</pre>
<p>When the function is confirmed, select the CAL mode under Unit. Enter a name for the unit required by the operator and set the percentage of drift required.</p>		<pre>PARAM/Pr001/FUNCT/R. UNITS : CAL NAME: XXXXX CAL. drift: 020 %</pre>
<p>In the SPE CYCLE menu select "CAL learn" and confirm with the ENTER key.</p>		<pre>SPE CYCLE Regulator adjust Infinite fill CAL. Learning</pre>
<p>Adjust the calibration instruction (generally the value of the master leak connected to the instrument). Confirm with the ENTER key.</p>		<pre>SPE C/CAL Learning INSTRUCT. : 150.0</pre>
<p>The display confirms that the special cycle is selected.</p>		<pre>MAIN MENU PARAMETER SPE CYCLE: CAL. Lrn CONFIGURATION</pre>

<p>Press on the START key to start the learning cycle. At the end of the cycle the display gives the test result in the calibration unit.</p>		<pre>CYCLE/Pr: 001 PRESS = 20.0 mbar FLOW = 160 XXXXX TEST</pre>
<p>Once this is done, the calibration cycle stops of its own accord.</p>		<pre>CYCLE/Pr: 001 PRESS = 20.0 mbar FLOW = 160 XXXXX READY (OK)</pre>



Note: the CDF (Leak/Flow calibrator) can be used to calibrate the instrument and transmit the value via the infra-red link.

3.6.2. CAL check

This special cycle allows the checking of the adjustment (calibration) in calibrated mode. Refer to the previous paragraph. The CAL check cycle controls if the calibration has not drifted beyond the limits imposed as a percentage. In the event of an exceeding of the limits a warning will be set off and a calibration cycle or a checking of the instrument will be necessary.

Otherwise the "good part" and "cycle end" or "bad part" and "cycle end" indicators will be activated depending on the measurement made in relation to the reject thresholds.

The CAL check request can be carried out on input 7 of the J3 connector programmed for this function, or through a programmed function key on the optional RC5 console if it is installed.





<p>From the main menu, place the cursor in front of the CYCLE SPE option and confirm with ENTER.</p>		<pre>MAIN MENU RUN PROG.: 001 PARAMETERS SPE CYCLE: Disabled</pre>
<p>Next, place the cursor in front of CAL check and validate with the ENTER key.</p>		<pre>CYCLE SPE Infinite fill CAL learning CAL check</pre>
<p>Press on the START key to start the checking cycle. The checking cycle stops of its own accord.</p>		<pre>MENU PRINCIPAL RUN PROG.: 01 PARAMETERS SPE CYCLE: CAL check</pre>
<p>At the end of the cycle, the display gives the result of the test in the calibration unit.</p>		<pre>CYCLE/Pr: 001 PRESS = 20.0 mbar FLOW = 160 XXXXX READY (OK)</pre>

3.6.3. Single calibration

The "Single CAL" function or single calibration allows to validate or not the current calibration for all the programs who measuring in personal calibration mode.

This is allowing carrying out only one calibration learning cycle that will be valid for all the measurement programs under the personal measurement "CAL" units.

The validation of the single calibration parameter is doing like the following kind:





<p>In the "PARAMETERS/PrXXX/FUNCT" menu, place the cursor in front of "SINGLE CAL".</p>	 	<pre>PARAM/Pr001/FUNCT/R. Drift CAL.: 020 % NAME : SINGLE CAL : No</pre>
<p>Validate by "Yes" the function "SINGLE CAL". So the calibration is valid.</p>	 	<pre>PARAM/Pr001/FUNCT/R. Drift CAL.: 020 % NAME : SINGLE CAL : Yes</pre>

Note: the programs that stay with classical measurement units (no personal calibration) are not concerned by the single calibration.

3.7. ATR LEARNING

If the transient values are not known, a transient learning cycle must be carried out so that the instrument can calculate and enter the values. These learning cycles are located as shortcuts in the special cycle menu, on input 7 of connector J3 programmed for this function or on a programmed function key on the optional RC5 keypad, if this is installed.

When transient values are not known, a learning cycle must be carried out for the transient so as to enable the instrument to calculate and enter the values. These learning cycles are found in brief in the special cycle menu.

<p>If no transient learning has been carried out, the message ATR DEFAULT will appear.</p>		<pre>CYCLE/Pr : 001 PRESS = 1.50 bar LEAK = ATR ERROR READY (NOIO)</pre>
<p>To carry out the learning, select the SPE CYCLE menu.</p>		<pre>MAIN MENU RUN PROG. : 001 PARAMETERS ▶SPE CYCLE : Regul.</pre>
<p>Then select the ATR Learning menu.</p>		<pre>SPE CYCLE CAL learning CAL check ▶ATR learning</pre>
<p>The display confirms that the special cycle has been selected.</p>		<pre>MAIN MENU RUN PROG. : 001 PARAMETERS ▶SPE CYCLE : ATR</pre>
<p>Press the START button to start the learning cycle. At the end of the cycle, the display gives the test result for the good part.</p>		<pre>CYCLE/Pr : 001 PRESS = 1.50 bar LEAK = -004 Pa TEST</pre>
<p>The instrument carries out a test cycle, and then continues the cycle by carrying out a learning cycle. When the cycle has been completed, the transient values are recorded.</p>		<pre>CYCLE/Pr : 001 PRESS = 1.50 bar LEAK = 000 Pa ATR</pre>
<p>To view the transient values, press ENTER. <i>Note: these values can be modified manually.</i></p>		<pre>ATR2 ▶Initial : -000 Transit. : -003 Tolerance : 020 %</pre>









4. SERVICE MENU

4.1. SERVICING OF THE PARAMETERS

This menu allows the saving, recovery or deletion of the test cycle parameters.

- ✓ **Save menu:** allows the saving of the test parameters and the configuration of the moment.
- ✓ **Restore menu:** allows the recovery of a previously saved configuration.
- ✓ **Reset menu:** allows the deletion of all the parameters.

To access the menu, place the key to the **ACCESS**  position.

<p>In the main menu, place the cursor in front of the SERVICE title and validate with ENTER.</p>	 	<pre> MAIN MENU CYCLE SPE: Disabled CONFIGURATION SERVICE </pre>
<p>Next, place the cursor in front of the PARAMETERS function and validate with the ENTER key.</p>	 	<pre> MENU /SERVICE PARAMETERS SENSOR </pre>
<p>Next, place the cursor in front of the required action:</p> <p>SAVE: save the current parameters,</p> <p>RESTORE: to replace the current parameters by those saved in the memory,</p> <p>DELETE: to delete the current parameters and return to the initial configuration,</p> <p>And validate with ENTER.</p>	 	<pre> MENU/SERVI/PARAMETE SAVE : No RESTORE : No RESET : No </pre>
<p>To activate an operation, confirm with the ENTER key. Next, choose YES with the navigation keys, then confirm again with the ENTER key.</p>	  	<pre> MENU/SERVI/PARAMETR SAVE : Yes RESTORE : No RESET : No </pre>

Turn the key to the **LOCKED**  position.

Note: if the parameters have been modified and there is a difference between the current and the saved parameters, when the instrument is switched on, or the key is turned to the locked position, the following message appears on the screen:

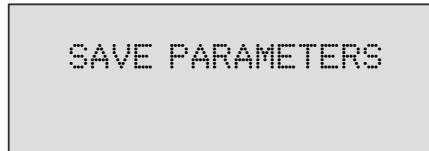





This message does not block the instrument and disappears after a few seconds. It informs that a save operation may be necessary. In this case, three solutions are available:

- 1) **Recover** the saved parameters (the current parameters will be lost).
- 2) **Save** the current parameters in the memory (the parameters already saved will be lost).
- 3) **Do nothing** and work with the current parameters.

4.2. SERVICING OF THE SENSORS

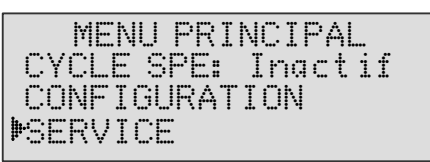
This menu allows the monitoring of the information that is communicated by the pressure sensors, "**PRESSURE**" for the absolute pressure piezo sensor and "**LEAK**" for the differential pressure sensor.

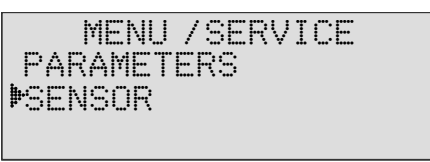
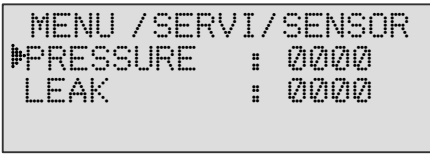
<p>In the main menu, place the cursor in front of the SERVICE heading and confirm with the ENTER key.</p>	 	
<p>Next, place the cursor in front of SENSORS and confirm with the ENTER key.</p>	 	
<p>The screen displays the values measured by the pressure sensors.</p>		

5. RESULTS MENU

This function allows:

- ✓ the display of the test result details: number of parts tested, number of good parts, number of bad reference parts, number of bad test parts, number of recoverable parts, number of times when the alarm has been set off (each indicator is expressed in %),
- ✓ to reset to naught the results memory,
- ✓ to print the test results (number of good parts, number of bad parts).

6. LANGUAGE MENU

This function allows the choosing of the instrument language. Several languages are available. Two are installed at the fabrication of the instrument. The English is the language by default the other is chosen by the customer.



7. STAND-BY MENU

This function allows the switching off of the instrument without unplugging it from the mains power supply. The switching to stand-by can be immediate or programmed with hours of operation and hours of rest.

The immediate switching to stand-by can be carried out in two different ways:

1) Either through the Stand-by menu,

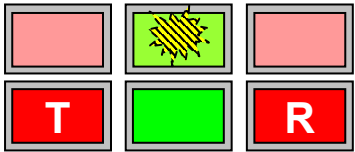













2) Or by pressing for more than three seconds on the **RESET**  button

<p>Note: when the instrument is on stand-by the display is switched off and only the yellow indicator emits flashes about every 3 seconds.</p>		
<p>To reactivate the instrument just press on any of the front panel keys.</p>		

☞ Select the option and proceed to adjust if necessary.

7.1. STANDBY USING THE MENU

Standby using the menu enables start and stop times for the instrument to be programmed.

<p>In the main menu, position the cursor beside STANDBY and confirm by pressing ENTER.</p>	 	<pre> MAIN MENU RESULTS LANGUAGE : English STAND-BY </pre>
<p>To program automatic standby at a given time, position the cursor beside STOP TIME.</p>	 	<pre> STAND-BY Now : No Pow-on time : No STAND-BY : No </pre>
<p>Confirm the STOP TIME parameter using YES</p>	 	<pre> STAND-BY Now : No Pow-on time : No Pow-off time : Yes </pre>
<p>Then set parameters for the time (hours and minutes) when the standby must take effect. "TIME DELAY" is the delay (in minutes) between the programmed time and actual standby</p>	 	<pre> STAND/Pow-off time HOUR : 00 MINUTE : 00 Delay : 00 </pre>
<p>To program the start-up time for the instrument, position the cursor beside START TIME</p>	 	<pre> STAND-BY Now : No Pow-on time : Yes Pow-off time : Yes </pre>
<p>Confirm the START TIME parameter using YES</p>	 	<pre> STAND-BY Now : No Pow-on time : Yes Pow-off time : Yes </pre>
<p>Then set parameters for the instrument start time (in hours and minutes).</p>	 	<pre> STAND/Pow-on time HOUR : 00 MINUTE : 00 </pre>

Chapter 5

ACCESSORIES

1. ACCESSORIES SUPPLIED WITH THE INSTRUMENT

1.1. POWER SUPPLY

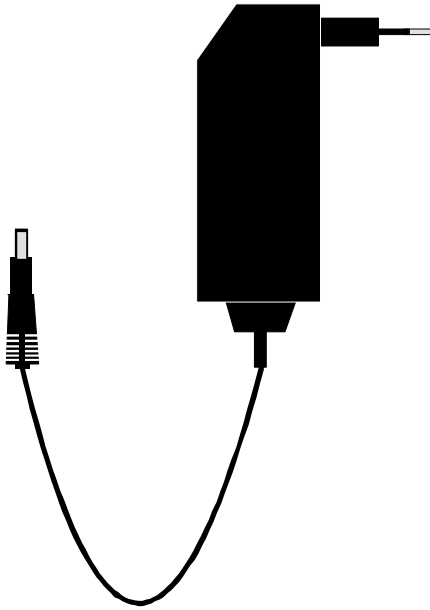

The power supply of the **D520** converts a network voltage (120 to 240 V AC) into a low voltage 24 V DC power supply. The adaptor does not have a switch; it works as soon as it is connected. It is protected against surges and short circuits through a thermal fuse (do not use fuses of another type).

2. OPTIONAL ACCESSORIES

2.1. FLOW MASTER LEAKS

The flow master leaks are used to check the calibration of flow measurement instruments. They are delivered in a case, attached to a connector which depends on the value of the flow are delivered with a calibration certificate.

PRESSURE	Nozzle type/flow in dm ³ /h (air to 15°C and 1013 mbar)						
	10	20	35	59	80	112	160
2 kPa (20 mbar)	0,98	5	17	51	93	180	405
10 kPa (100 mbar)	2,64	13	40	117	221	387	922
25 kPa (250 mbar)	4,36	21	64	185	354	607	1473
50 kPa (500 mbar)	6,54	29	90	262	482	890	1947
100 kPa (1 bar)	9,6	43	129	372	676	1262	
150 kPa (1,5 bar)	12,4	54	162	468	850	1599	
200 kPa (2 bar)	15,0	65	194	545	1010	1909	
250 kPa (2,5 bar)	17,7	76	227	638	1185		
300 kPa (3 bar)	20,4	88	260	729	1357		
350 kPa (3,5 bar)	23,4	100	293	819	1524		
400 kPa (4 bar)	25,2	110	325	910	1694		

Note: the values displayed in the table above are given for information purposes; in effect the value of the standard leaks can vary by +/- 15%. The real flow rate of each master leak is accurately measured and given with an accuracy of +/- 1.5 %.

The master leaks:

- ✓ Must be used with clean and dry air.
- ✓ Must be stored in there boxes when not in use.
- ✓ Must be periodically cleaned in acetone or trichloroethylene.
- ✓ Must be checked periodically, to guarantee there accuracy (our metrology laboratory can carry out this service).

Option: a second master leak can be integrated if requested for the eventual control of the first or to replace it during a check.

2.2. NEEDLE VALVE AND LEAK FLOW CALIBRATOR

2.2.1. Needle valve

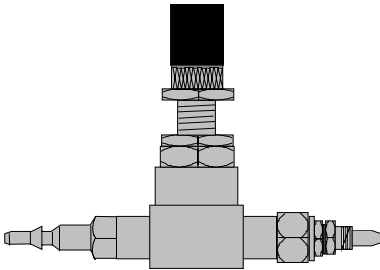

Needle valves are used to calibrate the leakage limits. These valves have an adjustable leak and depending on the model allow adjustments of between a few cm³/h to several l/min.

These valves can be easily disturbed and therefore require the frequent use of some means of checking the setting (eg: ATEQ Leak/Flow calibrator).

Note: it is strongly recommended that you do NOT leave a needle valve permanently connected on a leak detection machine with automatic calibration every "n cycles".

2.2.2. CDF (Leak/Flow Calibrator)

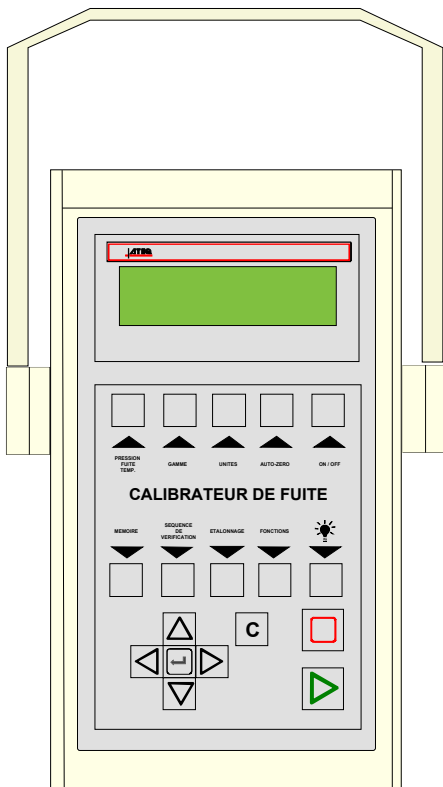

The **Leak/Flow calibrator** is a multiple range **ATEQ** flow meter intended for checking leak testing equipment and particularly **ATEQ** instruments. It measures a loss of charge with a differential sensor, which is connected to a calibrated flow tube.

2.3. AUTOMATIC CONNECTORS WITH EXPANDABLE JOINTS

ATEQ automatic connectors are used so that accurate and reliable assemblies can be built to check air tightness. They simplify the work of the operator as they are self-locking thanks to the use of a pneumatic valve supplied from the mains compressed air supply. Several connectors may be controlled by the same remote, powered by an **ATEQ** or another logic.

They adapt easily to a large number of fittings and apertures of varied dimensions. Their use ensures that non-machined walls can be guaranteed airtight.

There are four basic versions of **ATEQ** automatic connectors:

- ✓ SA for external connections,
- ✓ SI for internal connections,
- ✓ SAG and SIG for threaded and tapped connections.

They are either in anodised aluminium or stainless steel as standard. Different types of joints are available depending on the elasticity required.

2.3.1. Operation

The connector is positioned manually or automatically using a jack or cylinder.

Compressed air is allowed through the control aperture via a three part valve. The pressure pushes the cylinder which squashes the connector. The air tightness is therefore perfect and there will be no leakage in the connector seals.

2.3.2. Standard dimensions

SAG and SIG have been designed for threaded and tapped caps. For the time being, they are available in gas norm. Sizes, which are: 1/2", 3/4", 1", 1 1/4", 1 1/2", 2", BSP.

The SA and SI are designed for smooth nozzles, with dimensions from 3 to 80 mm for the external diameters (SA), and from 10 to 75 mm for the internal diameters (SI).

2.4. FILTRATION KIT

For an increased reliability of the instruments, it is necessary to use clean and dry air.

The filtration kit is connected to the air input on the rear panel of the instrument.

It is composed of a dust removal cartridge (5µm) and another cartridge (0,01 µm) to reduce the residual oil pollution to 0,01 ppm.

2.5. REMOTE CONTROLS

The remote control allows control and selection of various settings remotely for instruments in the **ATEQ** range. The remote is to be connected on the Input/Output connector.

2.5.1. Reset/Start casing

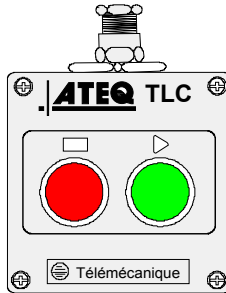

2.5.2. Four functions S5 remote control

This remote control has four functions which can be used to control a series 5 instrument remotely. (F580 or C540 single head only).

The four functions on this remote control are as follows :

- ✓ RESET and start cycle.
- ✓ Increase or decrease program numbers.
- ✓ Display the number of the program selected.
- ✓ Display the test result, green indicator light for Pass, red indicator light for Fail or alarm.

Note: a program number can only be changed (increase or decrease) when no test cycle is running.

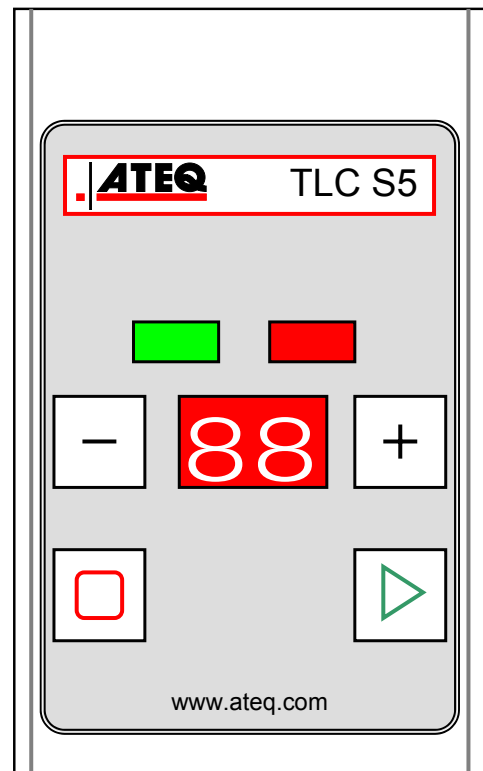

2.5.2. 1) Connection details

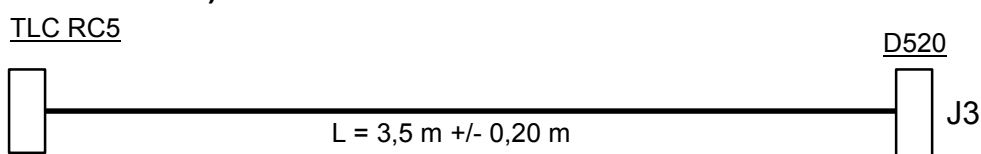

2.6. REMOTE FRONT PANEL RC5

2.6.1. Presentation

This option allows the placing of the control station in a different place than the control instrument; it allows the remote control and reading of results. This is useful when the measurement instruments have to be positioned in inaccessible locations, such as inside a machine to reduce the lengths of piping between the instrument and the test part

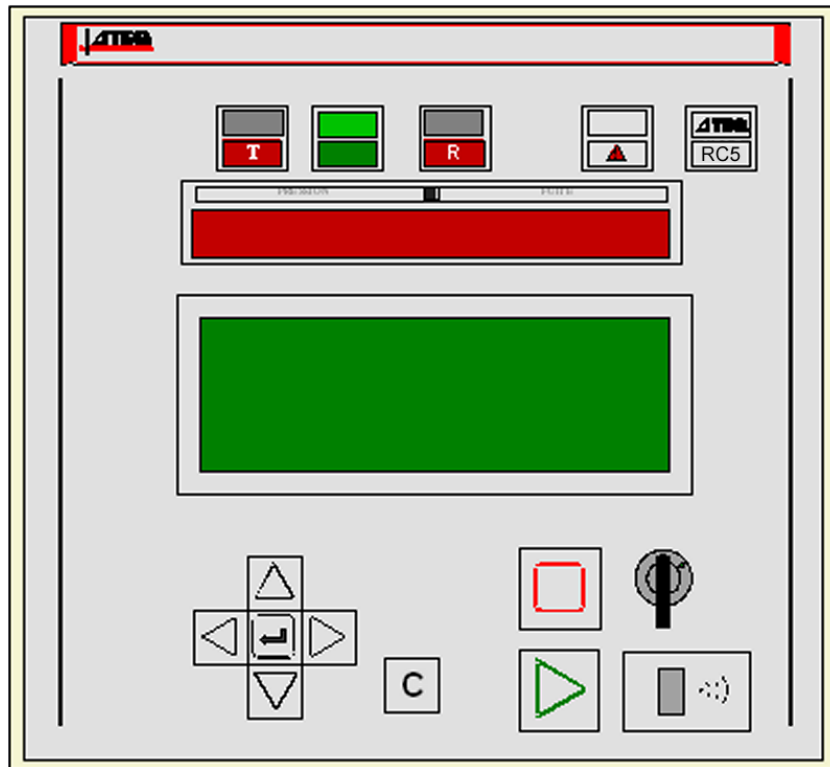

This front panel acts exactly as if the operator was in front of the instrument itself. For the interface, refer to the global operation of the instrument.

This remote control is optional. It is connected to the LUMBERG type connector reserved for remote controls. It is of "plug and play" type, the instrument automatically detects it, and the "REMOTE CONTROL" menu appears if the RC5 remote control is connected.

When the remote control is installed, its keyboard obtains priority over the control instrument's keyboard which becomes inactive.

2.6.2. Installation

2.6.2. 1) Connect to the measurement instrument

a) J5 RS485 connector (remote control)

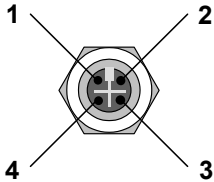

Allows the connection of an intelligent remote control. (Female Lumberg type connector). Optional.

PIN 1	Network
PIN 2	Power supply + 24V
PIN 3	Network
PIN 4	Ground 0V

2.6.2. 2) Connector on the RC5

a) RS485 connector (Input)

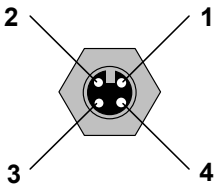

Allows the connection of the option to the remote control input of the **ATEQ instruments**. (Male Lumberg type connector).

PIN 1	Network
PIN 2	Power supply + 24 V
PIN 3	Network
PIN 4	Ground 0V

2.6.3. Start-up

Before connecting the instruments, turn them off, when the network is installed it automatically detects the presence of the RC5 remote front panel when the instrument is switched on.

If the remote front panel is equipped with a multifunction intelligent remote control (8 keys) refer to the paragraph concerning this accessory.

2.7. INTELLIGENT REMOTE CONTROL

2.7.1. Presentation of the remote control

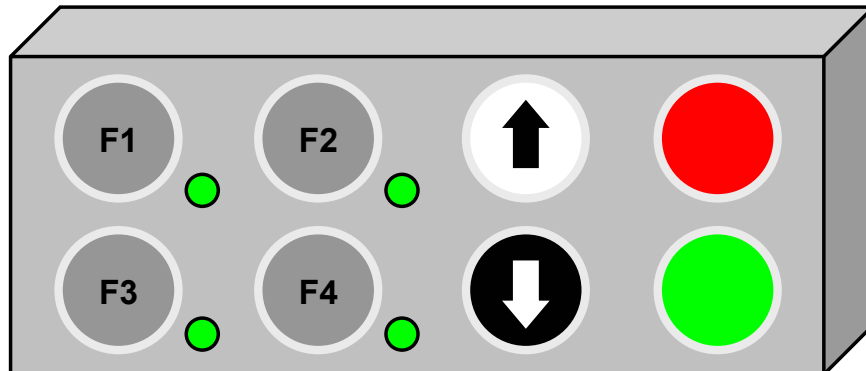

The remote control allows the remote operation and selection of various functions of the instrument in the **ATEQ** range.

This interface can only be installed with an RC5 type remote front panel with the intelligent remote option.

2.7.2. Programmable keys

This remote control is fitted with four function keys (F1, F2, F3 and F4) which can be programmed by the operator to fit his requirements (four buttons on the left). When a special cycle is used on a function key, it no longer appears in the menus for the other function keys.

The programmable functions are all the special cycles and the cycle start (the cycle start function allows the simulation of a two handed remote control).

Note: the synchronisation between the two buttons is of 300 ms, the two handed remote control is not a high security function; the ATEQ company would in no event be responsible if an accident should occur on an operator following its improper use.

2.7.3. Programmable cycles

The programmable special cycles on the function keys F1 to F4 are the following:

Disabled.

Regulator adjustment.

Infinite fill.

Piezo Auto-zero.

Calibration check.

CAL learning.

CAL check.

ATR learning.

Start.

2.7.4. Indicators

The L.E.D. tricolour indicators situated near the F1 to F4 keys allow the display of the state of the cycle requested:

- **green**, cycle ok,
- **red**, cycle bad,
- **orange** cycle in progress.

2.7.5. Fixed function keys

The four other push to make buttons (situated on the right hand side) are the push buttons possessing the following functions:

- selection of the rise program (white),
- selection of the drop program (black),
- cycle start button (green),
- cycle stop/reset button (red).

Reminder: these buttons functions are fixed and cannot be modified.

2.7.6. Installation of the remote control on the RC5

Pins	J2 connector (outputs)		J3 Connector (inputs)	
	24 V 10 mA Outputs	L.E.D.	Inputs	Functions
1	Green anode	F1	Input 1	F1
2	Cathode (0 V)		24 V	
3	Red anode		Input 2	F2
4	0 V	24 V		
5	Green anode	F2	Input 3	F3
6	Cathode (0 V)		24 V	
7	Red anode		Input 4	F4
8	0 V	24 V		
9	Green anode	F3	Input 5	RISE
10	Cathode (0 V)		24 V	
11	Red anode		Input 6	DROP
12	0 V	24 V		
13	Green anode	F4	Input 7	RESET
14	Cathode (0 V)		24 V	
15	Red anode		Input 8	START
16	0 V	24 V		

2.8. EXTERNAL CUTTING VALVE

This valve is proposed in option with the instrument, it allows to stop the gas or air flow out of cycle.

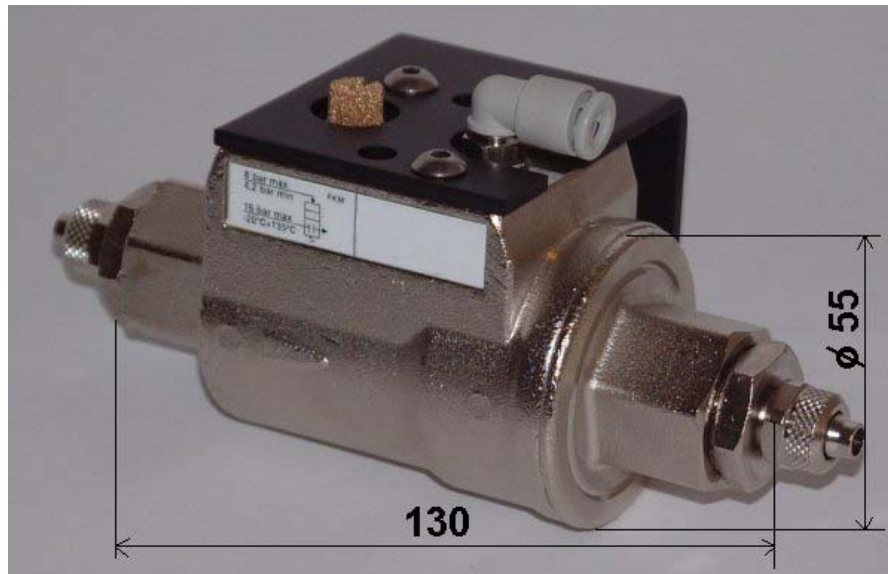





The driving of this valve is pneumatic, by the **ATEQ D520**.

Chapter 6

ERROR MESSAGES

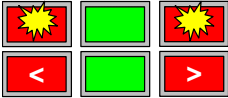
The **ATEQ D520** can display error messages if there are operational problems.

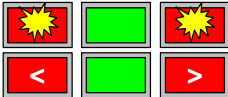
PROBLEM	LIT INDICATORS	MESSAGE DISPLAYED
<p>Test error. Leak in excess of the full scale. Action: check the test circuit.</p>		<pre> CYCLE/Pr: 001 PRESS = 20 mbar FLOW = >> F. S. TEST READY (NO OK) </pre>
<p>Pressure in excess of the full scale. Action: decrease the pressure using the mechanical regulator knob or the target if an electronic regulator is used.</p>		<pre> CYCLE/Pr: 001 PRESS = > F. SCALE READY (NO OK) </pre>
<p>Differential sensor error. Action: contact the ATEQ after sales service for repairs (probable presence of water or oil in the instrument test circuit).</p>		<pre> CYCLE/Pr: 001 PRESS = 20.2 mbar FLOW = SENSOR ERR. READY (NO OK) </pre>
<p>Pressure in excess of the max. threshold. Action: check regulator settings, pressure limits, check whether the right regulator has been selected if there are two.</p>		<pre> CYCLE/Pr:001 PRESS=1.02 bar P> READY (NO OK) </pre>
<p>Pressure below the min. threshold. Action: check the network pressure and regulator settings, the pressure limits, and whether the right regulator has been selected if there are two.</p>		<pre> CYCLE/Pr:001 PRESS=0.000 bar P< READY (NO OK) </pre>
<p>ATR error. Action: run another ATR learning cycle or check the ATR parameters. ATR fault.</p>		<pre> CYCLE/Pr: 001 PRESS = 19.8 mbar FLOW = ATR ERROR READY (NO OK) </pre>

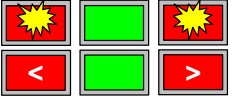
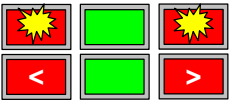
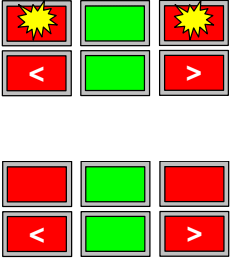
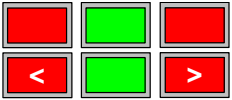
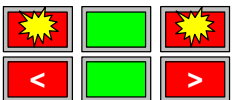
PROBLEM	LIT INDICATORS	MESSAGE DISPLAYED
<p>CAL fault : no CAL learning Action: carry out CAL learning</p>		<pre>CYCLE/Pr: 001 PRESS = 20.5 mbar DEBIT = CAL. ERROR READY (NO OK)</pre>
<p>CAL drift found following request for CAL check. Action: check the programmed percentage of CAL drift, the known standard leak and the test pressure.</p>		<pre>CYCLE/Pr: 001 PRESS = 20.4 mbar DEBIT = CAL. DRIFT READY (NO OK)</pre>
<p>1) The electronic regulator has been unable to initialise correctly. 2) The input pressure on the regulator must be at least 10 % of regulator full scale + 100kPa (+ 1 bar). Action: check supply network pressure or pressure at the regulator input.</p>		<p>The indicator lights come on briefly after the following message is displayed:</p> <pre>REGULATOR ERROR</pre>
<p>PROG error: the I/O's have selected a program with no parameters. Action: enter program parameters.</p>		<pre>CYCLE/Pr: 09 ERROR</pre>
<p>Inappropriate size for the selected unit of pressure. Action: change unit or modify the minimum and maximum pressure limits if these and the test pressure can be used with this unit.</p>		<pre>PARAM/Pr 001 >Press. UNIT: PSI MAX. FILL: PPPP MIN. FILL: 0.15</pre>
<p>The reference master jet drift is higher than the instruction in percent. Action: check the master jet and realise a "drift acquit" special cycle.</p>		<pre>CYCLE/Pr: 001 PRESS = 20.4 mbar DEBIT = REF. DRIFT READY (NO OK)</pre>

Chapter 7

OPERATIONAL PROBLEMS

1. PHENOMENON NOTED

If a test machine begins to detect too many bad parts (statistically, more than three consecutively), it is advisable to carry out a **check on the whole unit**. The quality of the manufacture and operation of the leak detector should be the last things considered.

1.1. CONDITION OF THE MACHINE'S SEALS

This is the no.1 defect as the seals are subject to high levels of dirt contamination (alumina, shavings). Regular cleaning of the seals is an effective remedy.

1.2. DAMAGED INSTRUMENT SEALS

There is a possibility that the seals may be cut by shavings or worn by repetitive squashing. This can be prevented by regular servicing and replacement of the seals.

1.3. BUMPER PAD

This is a defect which may occur after a certain amount of time as the bumper pads may be worn, or if the pressure settings in the air cylinder are inadvertently disturbed. Check the stability of the measurement and that the bumper pads are correctly installed.

1.4. PNEUMATIC LINK

The link and reference pipes will age and break with time. The pipes and seals must conform to the required quality. **ATEQ** recommends the use of RILSAN PA11 pipes and AVS type joints.

1.5. ENVIRONMENT

A measurement may be affected by a variation in background temperature (sun, draughts, storage of parts outdoors, handling of the test part by the operator, ...).

The dampness of parts may cause errors in the readings (insufficient drying after washing, outdoor storage, condensation, presence of water in the fixture, ...).

1.6. CALIBRATION

ATEQ does not accept any liability in regard to calibrations and settings to its instruments which are not carried out by its own personnel.

1.7. CONCERNS ABOUT RELIABILITY OF THE INSTRUMENT'S CIRCUITS

If all the other checks do not resolve the problem, the instrument's circuit may be checked.

Proceed as follows:

- ✓ Segregate the instrument from its environment (pneumatic assembly),
- ✓ Place a calibrated master leak on the output,
- ✓ Choose an unused program,
- ✓ Set the parameters as follows :
 - ⇒ the regulator to the master leak test pressure,
 - ⇒ the pressure monitoring thresholds to +/- 20 % of the test pressure,
 - ⇒ coupling times A and B 0 seconds,
 - ⇒ fill time 1 second,
 - ⇒ stabilisation time 1 second,
 - ⇒ test time infinite,
 - ⇒ reject level maximum,
 - ⇒ unit flow rating of the master leak,
 - ⇒ function all functions cancelled.

Run two consecutive cycles.

The post test time result should be close to or equal to the value of the calibrated master leak.

Appendices

ATEQ D520

1. TECHNICAL CHARACTERISTICS OF THE D520

	D520
Size of the casing H x L x P (mm):	136 x 250 x 255
Dimensions with filter and regulator (mm):	136 x 250 x 370
Power supply:	24 VDC / 2 A Min 23,5 V ; Max 28 V
Pneumatic connections:	Flow function
Weight (kg):	about 7 kg
Format:	½ 19 inches
Temperatures:	
Of operation:	+10°C to +45°C
Of storage:	0°C to +60 °C

2. DIMENSIONS OF THE D520

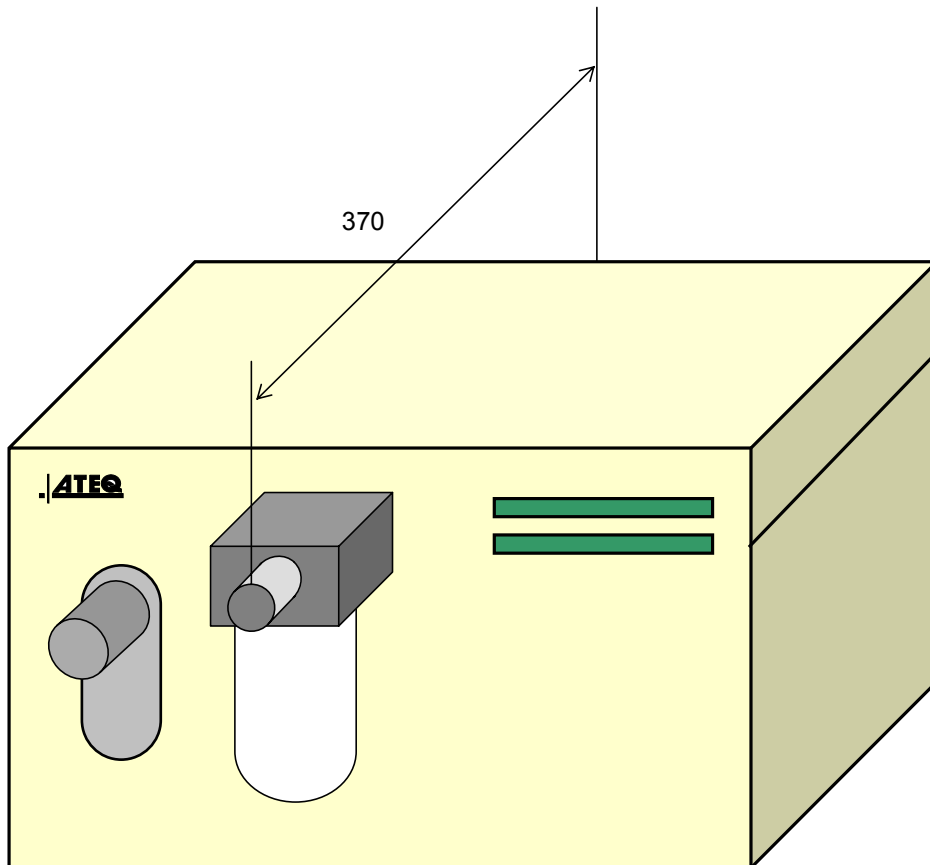
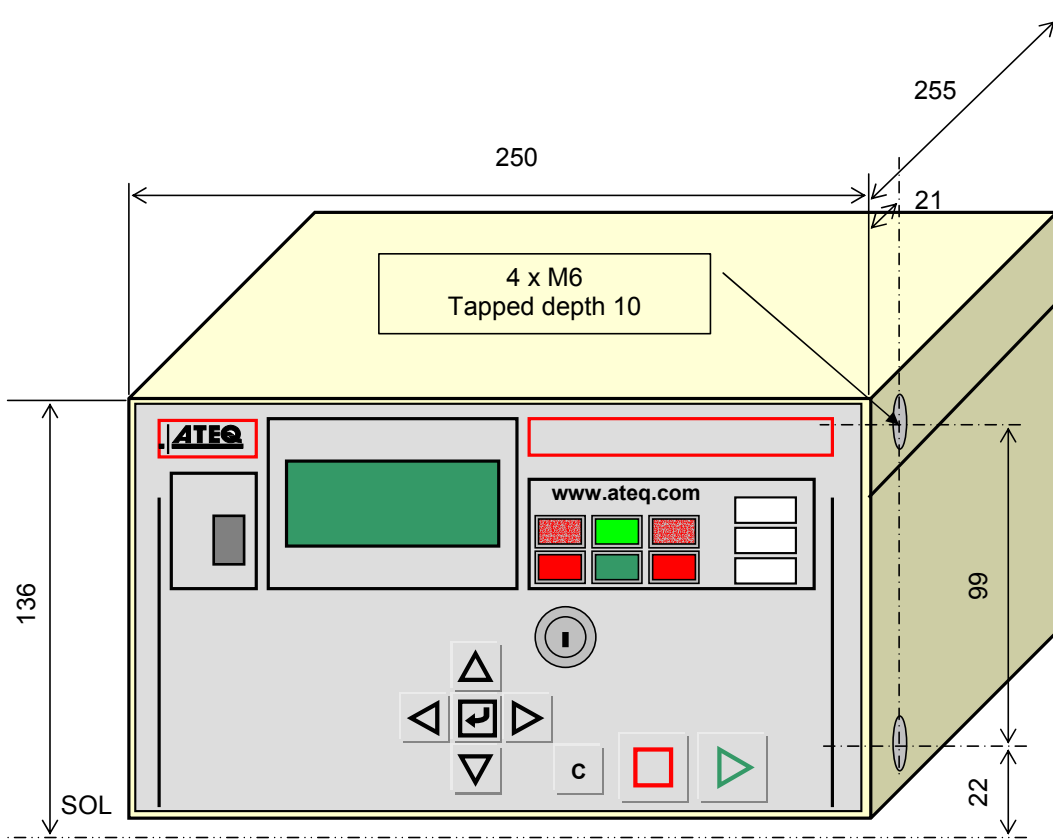

3. CONVERSION TABLE

		TO									
		Pa	kPa	bar	mbar	mmH2O	atm	Torr	psi	inH2O	inHg
FROM	Pa	1	10 ⁻³	10 ⁻⁵	10 ⁻²	0.10197	9.8692 10 ⁻⁶	7.5 10 ⁻³	1.45 10 ⁻⁴	4.01 10 ⁻³	2.95 10 ⁻⁴
	kPa	10 ³	1	10 ⁻²	10	101.97	9.8692 10 ⁻³	7.5	0.145	4.01	0.295
	bar	10 ⁵	10 ²	1	10 ³	10197	0.98692	750	14.5	401.46	29.53
	mbar	10 ²	10 ⁻¹	10 ⁻³	1	10.197	9.8692 10 ⁻⁴	0.75	1.45 10 ⁻²	0.401	2.95 10 ⁻²
	mmH2O	9.806	9.8067 10 ⁻³	9.8067 10 ⁻⁵	9.8067 10 ⁻²	1	9.6784 10 ⁻⁵	7.3556 10 ⁻²	1.4223 10 ³	3.937 10 ⁻²	2.895 10 ⁻³
	atm	1.013 10 ⁵	101.33	1.0133	1013.3	10332	1	760	14.695	406.78	29.921
	Torr	133.32	0.13332	1.3332 10 ⁻³	1.3332	13.595	1.3158 10 ⁻³	1	1.9337 10 ⁻²	0.535	3.937 10 ⁻²
	psi	6897.8	6.8948	6.8948 10 ⁻²	68.948	703.07	6.8045 10 ⁻²	51.71	1	27.68	2.036
	inH2O	249.09	0.2491	2.4909 10 ⁻³	2.4909	25.400	2.4583 10 ⁻³	1.8683	3.61 10 ⁻²	1	7.35 10 ⁻²
	inHg	3386.4	3.3864	3.3864 10 ⁻²	33.864	345.32	3.3421 10 ⁻²	25.4	0.491	13.595	1

5. VALVE CODES USED IN YOUR APPLICATION

GROUP PER PROGRAM:

PROGRAM	VALVE CODE	FUNCTION
01		
02		
03		
04		
05		
06		
07		
08		
09		
10		
11		
12		
13		
14		
15		
16		

Index

A	
Activation of an additional function	55
Additional functions	55
Adjust the main regulator pressure	89
Adjust the test parameters	36
Arrows keys	28
ATR cycle	58
ATR error	96, 111
ATR learning	96
Automatic connectors	61, 104
Automatic mode	57
Automatic Piezo reset	92
Automatic save	72
Automatic thresholds	90
Auxiliary outputs	62
B	
Bar code activation	84
Bar code option	83
Bar graph	76
C	
C540 / F580	78
CAL check	94
Cal drift error	112
CAL learning error	112
Calibrated mode test	93
Calibration	10
Calibration master leaks	102
Chain several test cycles	56
Characteristics	6
Control regulator	77
Conversion table	117
Coupling times A and B	37
Cutting valve	110
Cycle end	64
Cycle keys	29
D	
Delete a program	42
Delete a program name	42
Dimensions	116
Direct measurement	7
Display	30, 70
Display the detail of the results	99
Duplicate a program	40
E	
Electrical connectors	17
Electronic regulator	44
Electronic regulator error	112
Exporting the results under MS Excel	80
Extended menus	55
F	
Factory calibration	10
Fail large flow indicator	31
Fail low flow part indicator	31
Fill time	37
Fill type	60
Filtering	57
Filtration kit	104
Flow regulation	70
Flow test	35
Forced auto zero	92
Frames format	79
Front panel	27
Function keys	108
Functions	39
Functions menu	52
G	
Gas, option	69
I	
I/O configuration	86
Indirect measurement	8
Infinite fill	91
Inhibit the start key	81
Intelligent remote control	108
K	
Key lock	29
Keys	28
L	
Language	99
Leak/Flow calibrator	103
Lighting the screen	82
M	
Manual calibration	10
Maximum fill	38
Measurement cycle	11
Measurement principle	7
Mini valve	62
Minimum fill	38
Modbus	81
N	
Needle valves	103
No negative	62
O	
Offset	58
Operator mode	35
P	
P1 - P2	60
P1 - P2 correction	60
Parameter servicing	97
Parameters saved	118
Pass part indicator	31
Peak hold	59
Percent regulator	77

Personal notes.....	120	Sequence management.....	75
Personalize a program	56	Sequences.....	73
Pneumatic connectors	23	Sequences conditions.....	73
Power supply	101	Sequences utility.....	75
Pressure correction	58	Service menu.....	97
Pressure inferior to min threshold.....	111	Service parameters.....	114
Pressure over max threshold.....	111	Shut off valve	91
Pressure reset	58	Sign	69
Pressure too high	111	Simple remote control.....	105
Pressure variation.....	9	Single calibration	95
Principle.....	5	Stabilisation time.....	37
Print frame.....	78	Stamping	63
Print parameters.....	78	Standard conditions	57
Print the results.....	78	Stand-by	99
Printer.....	22, 78	Start the cycle.....	45
Program error	112	Stop the cycle	45
Programmable input	19	Symbols.....	12
	Q		T
Quick connectors.....	30	Take pressure socket	23
	R	Technical characteristics	115
Ranges	6	Temperature variation.....	9
RC5 remote control	87	Test error	111
Recoverable thresholds.....	59, 60	Test reject.....	38
Reference CAL.....	76	Test time	37
Regulator	30	Test types	35
Regulator adjust	71	Time.....	77
Regulator adjustment	44		U
Regulator frequency	77	Unit error.....	112
Remote control	22, 105, 107	Units	57
Remote front panel	106	Utility.....	75
Rest state	76		V
Results memory reset.....	99	Valve codes	61
RS232	22		W
RS485	22, 81	Warning	31
	S		
Security.....	81		
Sensor error.....	111		
Sensor servicing	98		

