

ATEQ F26 SPEED
Version 1.0



www.ateq.com

REVISION OF THE F26 SPEED USER MANUAL

| <u>Edition/ Revision</u> | <u>Reference</u> | <u>Date</u> (week/year) | <u>Chapters updated</u> |
|-------------------------------------|-------------------------|------------------------------------|--------------------------------|
| First edition | UM-29200A-U | 43/2007 | ----- |
| Second edition | UM-29200B-U | 17/2010 | General up date. |
| | | | |
| | | | |
| | | | |

DECLARATION OF  CONFORMITY 00

We the undersigned, **ATEQ**, manufacturers of the **ATEQ F26 SPEED REF : 292.00** declare that it complies with the requirements of :

- LOW VOLTAGE Directive 93/68/CEE regarding:

- standard EN 61 010-1 « Safety requirements for electrical equipment for measurement, control and laboratory use »,

- Directive CEM 89/336/CEE partially modified by Directive CEM 92/31/CEE regarding :

- standard EN 50 081-2 « Industrial environment emission generic standard »,
- standard EN 50 082-2 « Industrial environment immunity generic standard »,
- standard EN 61 000-4-2 « Test for immunity to electrostatic discharges »,
- standard EN 61 000-4-3 « Test for immunity to electromagnetic fields radiated at radio frequencies »,
- standard EN 61000-4-4 « Test for immunity to bursts of rapid electrical transients»,
- standard EN 61000-4-6 « Immunity to conducted disturbances induced by radiofrequency fields »,
- standard EN 61000-4-11 « Test for immunity relating to voltage dips, interruptions and variations in voltage ».

This enables **ATEQ** to guarantee that this instrument may be used in complete safety under the following environmental conditions :

- indoor use,
- altitude up to 3000 metres,
- ambient operating temperature from 5°C to 45 °C,
- 100 % maximum relative humidity without condensation,
- fluctuation in the supply network voltage not exceeding 15 % of nominal voltage
- temporary overvoltages in accordance with INSTALLATION CATEGORY II as in standard CEI 664,
- degree of pollution 2 as in CEI 664 (only non-conductive pollution. However a temporary conductivity caused by condensation may occasionally be expected).

Chairman and Managing Director
Mr. Jacques MOUCHET





Recommendations for leak testing instruments

Precautions for the test environment

- Keep the test area as clean as possible.

Precautions for the operators

- **ATEQ** recommends that the operators using the instruments should have a suitable qualification and training with respect to the work bench requirements.

General precautions

- Read the user manual before using the instrument,
- all electrical connections to the instrument must be equipped with a safety system (fuse, circuit breaker...) appropriate to its needs and complying with the standards,
- to avoid electromagnetic interference, the cable connections to the instrument should be less than two meters in length,
- it is essential that the electrical main is earthed,
- disconnect the electrical connections to the equipment before maintenance,
- cut the air supply for any kinds of operation on the pneumatic assembly,
- do not open the instrument when it is powered up,
- avoid water spillage near of the instrument,
- **ATEQ** is at your disposal for any further information concerning the use of the instrument under maximum safety conditions.



We would like to bring to your attention that ATEQ will not be held responsible for any accident connected to the improper use of the instrument, to the work bench or to the lack of compliance with safety rules.

ATEQ, THE ASSURANCE OF A COMPETENT AFTER SALES SERVICE

■ THE ATEQ AFTER SALES SERVICE IS :

- a team of qualified technicians,
- a permanent telephone assistance,
- agencies close to you for faster reaction,
- a stock of spare parts available immediately,
- a car fleet for rapid intervention,
- a commitment to quality ...

■ THE OVERHAUL

ATEQ carries out the overhaul of your instruments at interesting prices.

The overhaul corresponds to the maintenance of the instrument (checking, cleaning, replacing of used parts) as part of preventive maintenance.

Preventive maintenance is the best way to guarantee reliability and efficiency. It allows the maintenance of a group of instruments in good operational order and prevent eventual break-downs.

■ MAINTENANCE KITS

The ATEQ After Sales Service proposes, two kits destined for the preventive maintenance of the pneumatic circuits of instruments.

■ CALIBRATION

This may be carried out on site or in our offices.

ATEQ is attached to the COFRAC and delivers a certificate following a calibration.

■ TRAINING COURSES

In the framework of partnership with our customers, ATEQ offers two types of training in order to optimise the usage and knowledge of our instruments. They are aimed at different levels of technician:

- method / control training,
- maintenance / upkeep training.

■ A TARGETED TECHNICAL DOCUMENTATION

A number of technical documents are at your disposal to allow you to intervene rapidly in the event minor breakdowns:

- problem sheets describing and offering solutions to the main pneumatic and electronic problems,
- several maintenance manuals.

■ A QUALITY GUARANTEE

The instruments are guaranteed for parts and labour in our offices:

- 2 years for leak detection equipment,
- 1 year for electrical tests to norms instruments,
- 1 year for the accessories.

Our After Sales Service is capable of rapidly answering all your needs and queries.

We strongly recommend to send the instrument back to ATEQ once a year for re-calibration

PREFACE

Dear Customer,

You have just purchased an **ATEQ** instrument, we thank you for the trust you have placed on our brand. This instrument has been designed to ensure a long and unparalleled life expectancy, and we are convinced that it will give you complete satisfaction during many long years of operation.

In order to maximise the life expectancy and reliability of your **ATEQ** instrument, we recommend that you install this instrument on a secured workbench and advise you to consult this manual in order to familiarise yourself with the functions and capabilities of the instrument.

Our **ATEQ** After Sales Service centre can give you recommendations based on your specific operation requirements.

ATEQ

TABLE OF CONTENTS

| | |
|--|--------------------------------|
| PREAMBLE | 3 |
| 1. ATEQ F26 SPEED DEFINITION | 3 |
| 2. MEASUREMENTS CHARACTERISTICS | 4 |
| 2.1. Measurement ranges | 4 |
| 3. THE MAIN TYPES OF MEASUREMENT | 5 |
| 3.1. Direct/Pressure drop measurement | 5 |
| 3.2. Indirect/Pressure rise measurement | 5 |
| 4. DIRECT MEASUREMENT, PRESSURISATION..... | 6 |
| 5. SYMBOLS PRESENTATION | 7 |
| Chapter 1 | INSTRUMENT INSTALLATION |
| 1. ATEQ F26 SPEED PRÉSENTATION..... | 9 |
| 2. INSTRUMENT INSTALLATION | 10 |
| 2.1. Connectors on the F26 SPEED case..... | 10 |
| 2.2. Electrics connectors details..... | 11 |
| 2.3. Pneumatics connectors..... | 16 |
| Chapter 2 | USER INTERFACES |
| 1. F26 SPEED FRONT FACE PRESENTATION | 17 |
| 2. LIGHTS | 17 |
| Chapter 3 | START-UP AND SETTINGS |
| 1. POWERING-UP THE ATEQ F26 SPEED | 19 |
| 2. CHOICE OF THE PROGRAMME NUMBER..... | 19 |
| 3. TEST TYPE SELECTION | 19 |
| 3.1. Leak test (LEAK) | 19 |
| 3.2. Blockage test mode (P mode)..... | 20 |
| 3.3. Desensitized mode test (D mode)..... | 20 |
| 4. PARAMETERS ADJUST | 21 |
| 4.1. Waiting time (WAIT A)..... | 21 |
| 4.2. Fill time (FILL TIME)..... | 21 |
| 4.3. Stabilization time (STAB) | 21 |
| 4.4. Test time (TEST)..... | 21 |
| 4.5. Dump time (DUMP)..... | 21 |
| 4.6. Pressure unit (PRESSURE UNIT) | 22 |
| 4.7. Maximum fill (MAX FILL)..... | 22 |
| 4.8. Minimum fill (MIN FILL)..... | 22 |
| 4.9. Reject unit (REJECT UNIT) | 22 |
| 4.10. Test reject (REJECT MAX) | 22 |
| 4.11. Pre fill (PRE FILL) | 22 |
| 4.12. Recoveries limits (Threshold recup.) | 23 |
| 4.13. End of cycle function | 23 |
| 4.14. Transient attenuation (ATR)..... | 24 |
| 4.15. Program sequencing | 25 |
| 4.16. Permanent dump..... | 25 |
| 4.17. System settings | 25 |
| 5. DUPLICATION OF A TEST PROGRAM | 26 |
| 6. DELETING A PROGRAM OR A PROGRAM NAME | 26 |
| 7. STARTING A CYCLE | 26 |
| 8. STARTING A MEASUREMENT CYCLE | 26 |
| 9. STOPPING A CYCLE | 26 |
| 10. TEST PRESURE ADJUST | 26 |

| | |
|---|------------------------------------|
| Chapter 4 | FUNCTIONS OF THE INSTRUMENT |
| 1. MENU STRUCTURE..... | 27 |
| 1.1. Main menu..... | 27 |
| 1.2. Special cycle menu | 29 |
| 2. SYSTEM SETTINGS..... | 30 |
| 2.1. Dump level | 30 |
| 2.2. Inputs 6 and 7 configuration (IN6 / IN7) | 30 |
| 2.3. Handshake | 30 |
| 3. SPECIAL CYCLES MENU..... | 31 |
| 3.1. Special cycles available | 31 |
| 3.2. Special cycles starting..... | 32 |
| Chapter 5 | ACCESSORIES |
| 1. OPTIONAL ACCESSORIES..... | 33 |
| 1.1. Needle valve and Leak/Flow Calibrator (CDF) | 33 |
| 1.2. Calibrated leak | 34 |
| 1.3. Power supply..... | 35 |
| 1.4. Filtration kit..... | 35 |
| 1.5. Micro valve (option)..... | 35 |
| Chapter 6 | ERROR MESSAGES |
| ERROR MESSAGES | 39 |
| Chapter 7 | OPERATIONAL PROBLEMS |
| 1. PHENOMENON NOTED..... | 41 |
| 1.1. Condition of the machine's seals | 41 |
| 1.2. Damaged instrument seals | 41 |
| 1.3. Bumper pad..... | 41 |
| 1.4. Pneumatic air supply too low | 41 |
| 1.5. Pneumatic Link..... | 41 |
| 1.6. Environment | 42 |
| 1.7. Calibration | 42 |
| 1.8. Concerns about reliability of the instrument's circuits..... | 42 |
| Appendices | ATEQ F26 SPEED |
| 1. F26 SPEED TECHNICAL CHARACTERISTICS..... | 43 |
| 2. MECHANICAL DEFINITION DRAWINGS..... | 44 |
| 3. CONVERSION TABLE | 45 |
| 4. PERSONAL NOTES | 46 |
| Index | 47 |

PREAMBLE

1. ATEQ F26 SPEED DEFINITION

The **ATEQ F26 SPEED** is a compact air/air leak detector used to test the air tightness of parts on production lines. It is specially adapted for automatic and semi-automatic workbenches. The method used is based on the measurement of a small variation or drop in pressure with a piezzo sensor.

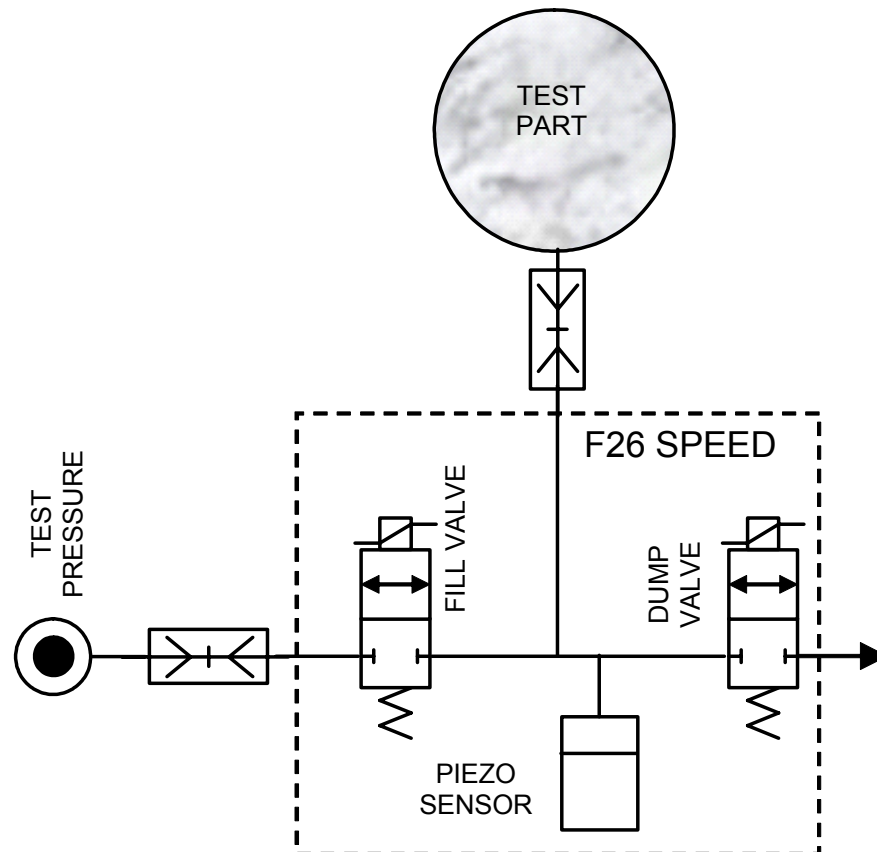

2. MEASUREMENTS CHARACTERISTICS

2.1. MEASUREMENT RANGES

| PRESSURE RANGES | MEASUREMENT RANGES | ACCURACY | maximum RESOLUTION |
|--|---------------------------|---------------------------|---------------------------|
| - 80 kPa > 0 (- 800 mbar > 0) | 500 Pa | +/- 4 % of the full scale | 1 Pa |
| | 1000 Pa | | |
| | 2000 Pa | | |
| | 5.00 kPa | | 10 Pa |
| - 50 kPa > 50 kPa (- 500 mbar > 500 mbar) | 500 Pa | +/- 4 % of the full scale | 1 Pa |
| | 1000 Pa | | |
| | 2000 Pa | | |
| | 5.00 kPa | | 10 Pa |
| 0 > 50 kPa (0 > 500 mbar) | 500 Pa | +/- 4 % of the full scale | 1 Pa |
| | 1000 Pa | | |
| | 2000 Pa | | |
| 0 > 200 kPa (0 > 2 bar) | 1000 Pa | +/- 4 % of the full scale | 1 Pa |
| | 2 000 Pa | | |
| | 5.00 kPa | | 10 Pa |
| | 10.00 kPa | | |
| 0 > 500 kPa (0 > 5 bar) | 2000 Pa | +/- 4 % of the full scale | 1 Pa |
| | 5.00 kPa | | 10 Pa |
| | 10.00 kPa | | |
| | 20.00 kPa | | |
| 0 > 1 MPa (0 > 10 bar) | 5.00 kPa | +/- 4 % of the full scale | 10 Pa |
| | 10.00 kPa | | |
| | 20.00 kPa | | |
| | 50.00 kPa | | |

3. THE MAIN TYPES OF MEASUREMENT

There are two main measurement methods that can be performed by the **ATEQ F26 SPEED**, direct measurement or indirect measurement. These two methods apply to measurements taken both under pressure and in vacuum conditions.

The configuration is determined by the application and must be carried out prior to the use of the instrument.

3.1. DIRECT/PRESSURE DROP MEASUREMENT

After filling the test part to the required pressure level, the instrument measures the drop in pressure.

At the end of a cycle, the **ATEQ** empties the components via the dump valve.

3.2. INDIRECT/PRESSURE RISE MEASUREMENT

The test part is placed in a sealed bell and the **ATEQ F26 SPEED** is pneumatically connected to the bell. The part is externally pressurized (with up to 20 MPa or 200 bar), and the bell is lightly pressurized. In the event of a part leakage, the pressure in the bell will rise. This method allows certain parts to be tested at high pressure levels whilst avoiding the associated constraints. The **ATEQ F26 SPEED** only tests and measures the pressure in the bell. In the event of a large leak, electronic monitoring of the pressure in the bell will switch the instrument to safety.

4. DIRECT MEASUREMENT, PRESSURISATION

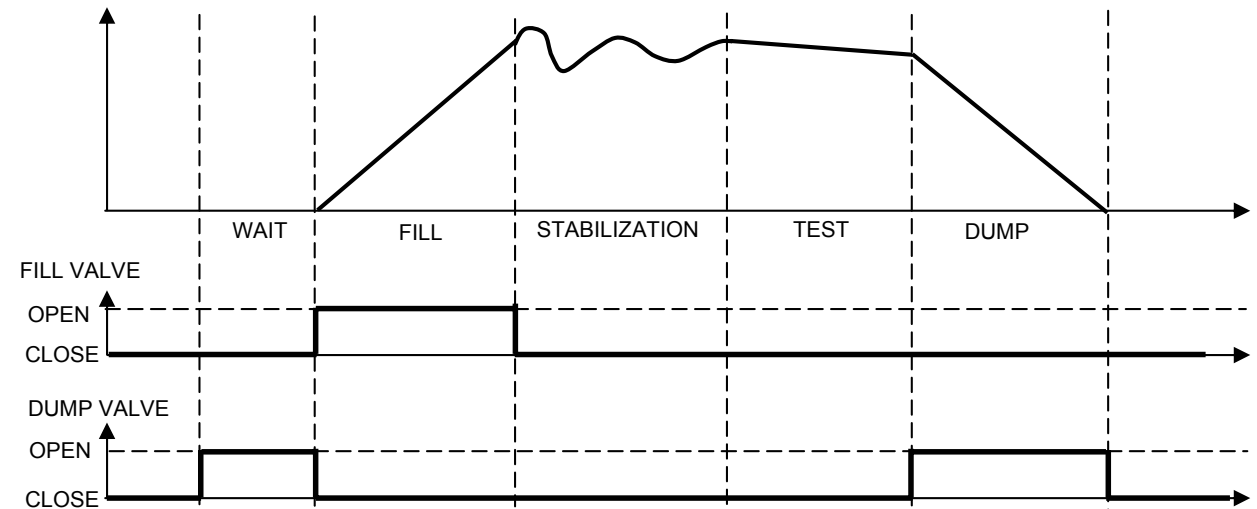

The measurement cycle consists of 5 phases:



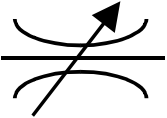
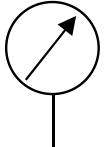
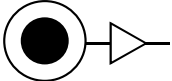
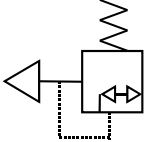
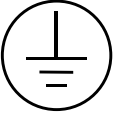
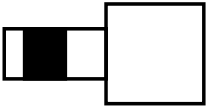
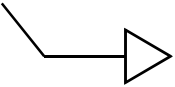

| | 1 | 2 | 3 | 4 | 5 | |
|-------|-------------|-------------|----------------------|-------------|-------------|-----------|
| Start | Wait | Fill | Stabilization | Test | Dump | Cycle end |

| | |
|-------------------------------|---|
| Start | Cycle start. |
| The wait time | The time during which the sealing connections are made before the part is filled. The instrument may be fitted with the optional automatic connector (this option adds an extra valve). This valve is driven during the cycle to enable the installation connectors. |
| The fill time | Pressurization of the test part. At the end of the fill time, the ATEQ instrument checks the test pressure. If this is not correct, the instrument will triggering a test pressure error. |
| The stabilization time | The test part is completely cut off from the air supply, but remains pressurized to the test pressure level. Pressure and temperature will then stabilize in the part. If the test pressure is wrong (large leak), the test pressure will drop rapidly, the instrument will not run to the test mode and will trigger an error. |
| The test time | Time during which the pressure sensor measures the changes in pressure in the test part. The signal is electronically processed and displayed, the part is then declared as pass or fail. |
| The dump time | Return of the part to atmospheric conditions. |
| Cycle end | Once the dump has been carried out, the instrument sends cycle end information and the automatic connector valve (optional) is deactivated. This valve can control one or several connectors. |

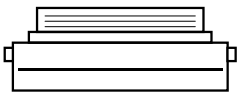
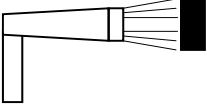
5. SYMBOLS PRESENTATION

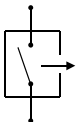
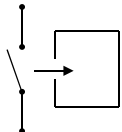
| Symbol | Name | Function |
|---|---------------------------|--|
|  | Adjustable leak connector | Pneumatic connector for the plugging of a calibrated leak (ruby kind) or an adjustable leak. |
|  | Pressure connector | Pneumatic connector for the plugging of a manometer for an external checking of the pressure. |
|  | Pressure supply | of the air supply from the 6 bar network. |
|  | Test circuit supply | Pneumatic connector (according to option) for the plugging of a supplementary pneumatic supply, used in the event of the test pressure being greater than 8 bar. |
|  | Ground connector | Connector for the electric connection to the ground. |
|  | Automatic connector | Pneumatic connector for the driving of an external logic or pneumatic components (pneumatic sealing connector). |
|  | Connector | Connector for a pneumatic output. |
|  | Connector | Connector for a pneumatic input. |
|  | Warning! | Read and respect the instructions of the user manual, before connecting and using the instrument. |
|  | Printer | Printer connection socket. |
|  | Bar code reader | Bar code reader connection socket. |

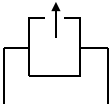
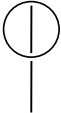
| Symbol | Name | Function |
|---|-----------------|--|
|  | Output | Dry contact output. |
|  | Input | Dry contact input. |
|  | USB link | USB ling. USB connector location for the connection of the device to a PC. |
|  | Analogue output | Analogue output. |
|  | Analogue input | Analogue input for the temperature sensor. |

Chapter 1

INSTRUMENT INSTALLATION

1. ATEQ F26 SPEED PRÉSENTATION



The **ATEQ F26 SPEED** is supplied in a blind painted sheet metal case, containing a pneumatic module (valves) and the electronic driver.

The instrument management is made from a PC fitted with the **Winateq300** software.

2. INSTRUMENT INSTALLATION

2.1. CONNECTORS ON THE F26 SPEED CASE



Front face and connectors.



Test output side.



Test pressure supply side.

2.2. ELECTRICS CONNECTORS DETAILS

2.2.1. Power supply

The **ATEQ F26 SPEED** instrument is running under a 24 V DC voltage. It must be connected to a power supply with 1.2 A minimum power.

The connection to this power supply is through the pin 2 (+24 V DC) and the pin 16 (0 V) of the relay board connector. See table below.

2.2.2. Inputs/Outputs All or Nothing connector

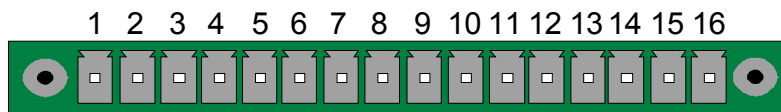

| Pin | Inputs/Outputs | Function | |
|-----|----------------|------------------------|---|
| 1 | Inputs 1 | Reset | INPUTS (Activation with 24 V DC) Common + 24 V = 0,3 A maxi |
| 2 | | Common (+ 24 V) | |
| 3 | Inputs 2 | START | |
| 4 | | Common (+ 24 V) | |
| 5 | Inputs 3 | Program selection | |
| 6 | Inputs 4 | Program selection | |
| 7 | Inputs 5 | Program selection | |
| 8 | Inputs 6 | Programmable inputs | |
| 9 | Inputs 7 | Programmable inputs | |
| 10 | | Floating common output | |
| 11 | Sortie 1 | Pass part | DRY CONTACT OUTPUTS 60V AC / DC Max 200mA Max |
| 12 | Sortie 2 | Fail part | |
| 13 | Sortie 3 | Not connected | |
| 14 | Sortie 4 | Alarm | |
| 15 | Sortie 5 | End of cycle | |
| 16 | | 0 V | |

2.2.2. 1) Activating a program from the J3 connector inputs

To activate a program from the J3 connector inputs, you have to select pins 5 to 7 (one or more). Binary weight $n + 1$.

- To select program number 1, send an impulse on another input selection and after send a start.
- The inputs are validated only on a changing state 0 to 1 (rising edge). A permanent state at value 1 don't update the input.
- If the running program is changed manually from the remote control, it stays at this number if it not changed from the PLC by a rising edge.

Pin combinations for program selection

| Program number | Pin 5 (Input 3) | Pin 6 (Input 4) | Pin 7 (Inputs 5) |
|----------------|-----------------|-----------------|------------------|
| 1 | 0 | 0 | 0 |
| 2 | 1 | 0 | 0 |
| 3 | 0 | 1 | 0 |
| 4 | 1 | 1 | 0 |
| 5 | 0 | 0 | 1 |
| 6 | 1 | 0 | 1 |
| 7 | 0 | 1 | 1 |
| 8 | 1 | 1 | 1 |

2.2.2. 2) I/O Connector (I/O Inputs/Outputs) programmable input

Inputs 6 (pin 8) and 7 (pin 9) parameters can be set in the **CONFIGURATION/CHANGIE I/O** menu.

The functions which can be programmed and are available on this input are all the specials cycle:

- ✓ Program selection.
- ✓ Regulator adjust request.
- ✓ Infinite fill request.
- ✓ Piezo auto zero request.
- ✓ Auto test request.

Some possibilities appear only if the function is used.

2.2.2. 3) Inputs / Outputs connector scheme

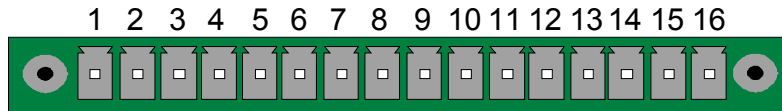

a) Connection ATEQ and PLC in NPN mode

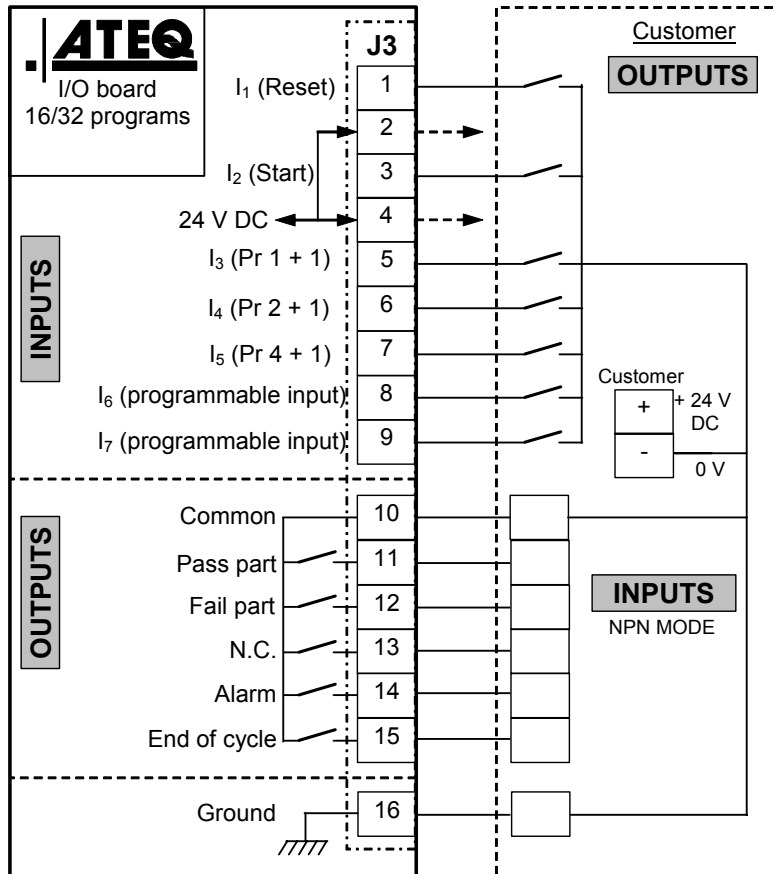

Note: The 24V power supply must be provided by the internal power supply of the ATEQ instrument (0,3A maximum) **OR** through an external power supply provided by the customer.

In NPN mode, the drive signal is active when its value is 0 V

b) Connection ATEQ and PLC in PNP mode

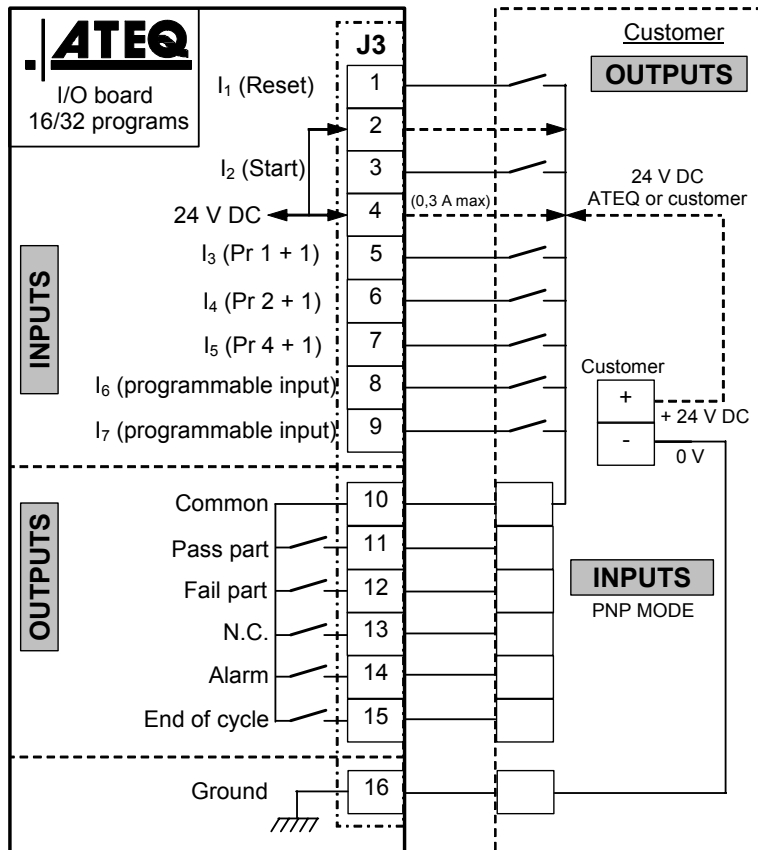

Note: The 24V power supply must be provided by the internal power supply of the ATEQ instrument (0,3A maximum) **OR** through an external power supply provided by the customer.

In PNP mode, the drive signal is active when its value is +24 V

c) Lights connection

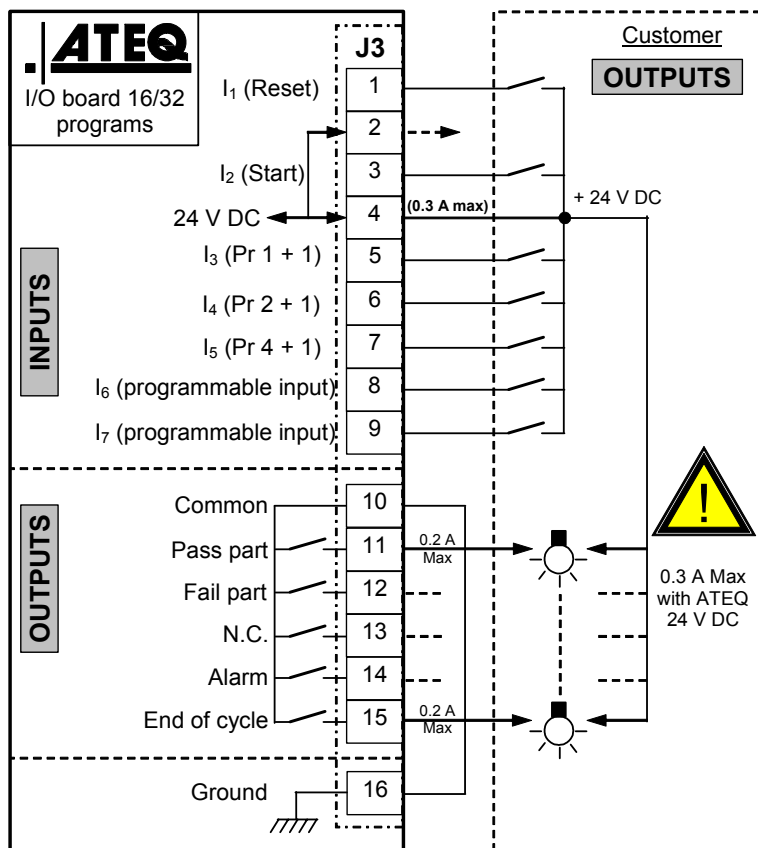

Note: The 24V power supply must be provided by the internal power supply of the ATEQ instrument (0,3A maximum) **OR** through an external power supply provided by the customer.

2.2.3. USB Connector (front face)



Allows the connection to a PC and then manage the device with the **Winateq300** software.

2.2.4. RS232 connector

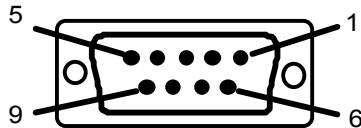

Allows the connection of a printer, a bar code reader, a PC, a memory module.

| | | | |
|-------|---------------------------|-------|---------------------|
| PIN 1 | Not connected | PIN 6 | + 5 V DC 200 mA max |
| PIN 2 | RXD Reception of the data | PIN 7 | RTS request to send |
| PIN 3 | TXD Sending of the data | PIN 8 | CTS clear to send |
| PIN 4 | Not connected | PIN 9 | Not connected |
| PIN 5 | Ground | | |

2.2.4. 1) Examples of RS232 cables

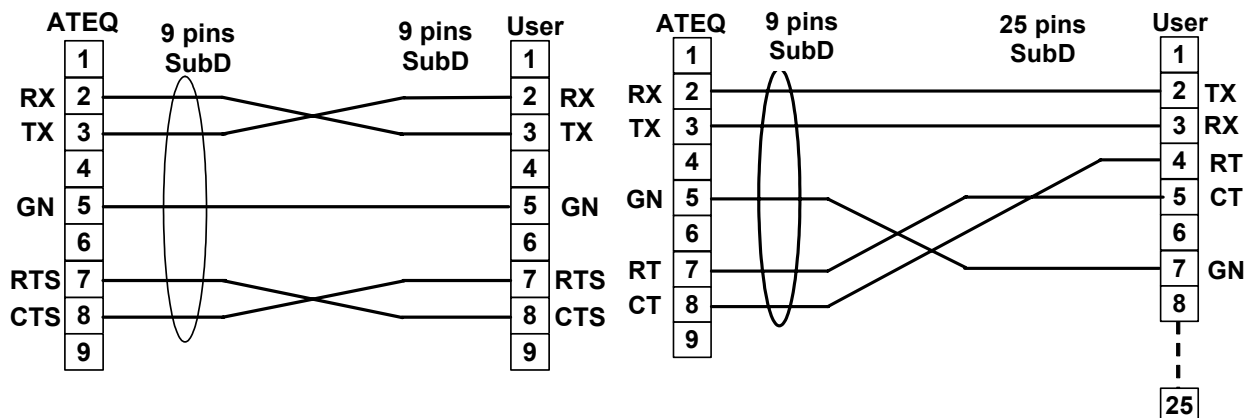

2.2.5. Ethernet connector (option)

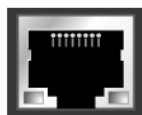
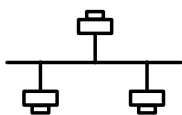

Ethernet connector. Allows connecting the device in an Ethernet network (network company), TCP/IP protocol. The configuration is done with the **Winateq300** software.

Network configuration: the device IP address is assigned by **DHCP**, do not validate the "Automatic IP" option.

Device IP address: **192.168.1.XXX** (XXX from **001** to **255**).

Subnet mask: **255.255.255.000**.

For the connection between a PC fitted with **Winateq300** software and several devices in Ethernet network, it must assign manually a different IP address at each device.

Note: the device Mac address (Microchip ATEQ Mac address) must always begin by **0004A3xxxxxx**.

2.3. PNEUMATICS CONNECTORS

2.3.1. Test outputs

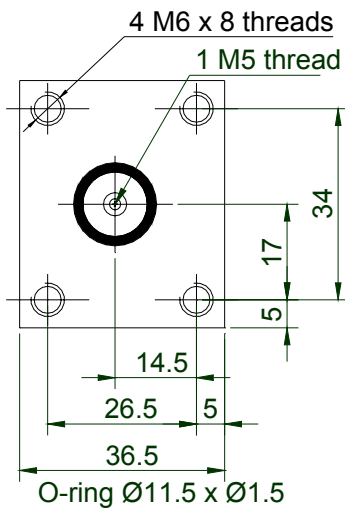

Test output: the leak test output is through the M5 hole.

The connection to the customer part can be done following two types as the customer preferences. Either by direct connection on the M5 tapping, either by fixing a part with the four M6 threads, the O-ring guarantying the sealing between the two components.

See complete drawing in appendices.

2.3.2. Test pressure input

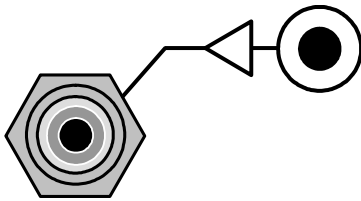

Test pressure supply. Connect and supply with the test pressure value.

2.3.2. 1) Pneumatic supply

It is essential that the air supplied is clean and dry. The presence of dust, oil or impurities may cause a malfunction.

When the instrument is working in vacuum conditions, impurities must be prevented from being drawn into it. For this purpose we strongly recommend that a suitable airtight filter is installed between the test part and the instrument. This filter can be supplied by **ATEQ**.

The presence of impurities, oil or humidity in the air may cause deterioration which will not be covered by the guarantee.

In accordance with ISO standard 8573-1 concerning classes of compressed air for measurement instruments in an industrial environment:

ATEQ recommends:

- | | | |
|--------------------------------|---------|---|
| • Grain size and concentration | CLASS 1 | (0.1 μm and 0.1 mg/m^3) |
| • Dew point under pressure | CLASS 2 | (- 40° dew) |
| • Maximum concentration of oil | CLASS 1 | (0.01 mg/m^3) |

ATEQ recommends the installation:

- of an air dryer to provide dry air at less than - 40° dew point,
- of a 25 micron and 1/100 micron double filter.

Chapter 2

USER INTERFACES

The management and the programming of the instrument is made with the Winateq software installed in a PC, this connected to the **F26 SPEED** through the RS232 link (serial communication port) or through the USB connector.

1. F26 SPEED FRONT FACE PRESENTATION

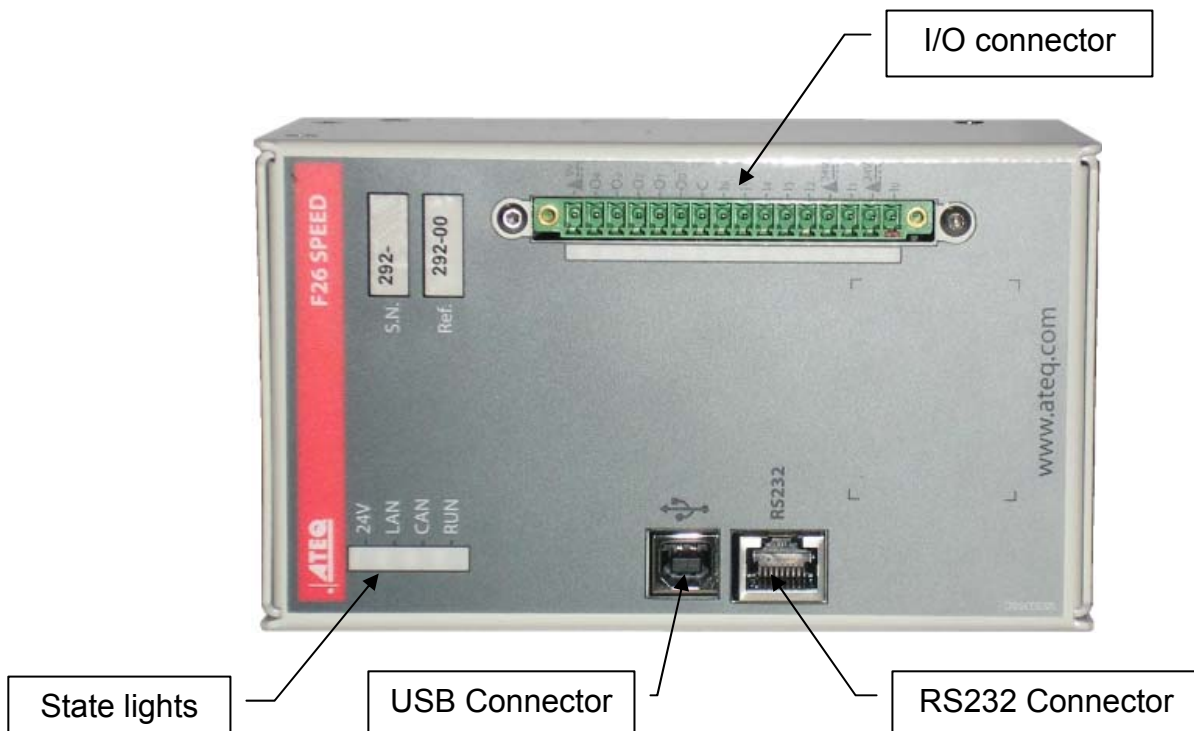

2. LIGHTS

Front face L.E.D.

| | | |
|---|------|----------------------------------|
| ● | 24 V | 24 V DC supply presence. |
| ● | LAN | LAN network communication light. |
| ● | CAN | CAN network communication light. |
| ● | RUN | Test cycle running light. |

Chapter 3

START-UP AND SETTINGS

For the **ATEQ F26 SPEED** configuration, the instrument must be connected to **PC** fitted with the **Winatq300** software.

| | |
|---|--|
|  | <p>Importante note</p> <p><i>For the parameters memorization after creation or modification in the device, it's imperative to:</i></p> <ul style="list-style-type: none"> ✓ Carry out one time a start cycle with the START function of the device or, ✓ Carry out a program number change and back to the current program, <p><i>Before every device turn off, else, the parameters modification won't be recorded.</i></p> |
|---|--|

1. POWERING-UP THE ATEQ F26 SPEED

Supply the instrument with 24 V DC power supply delivered with the instrument

2. CHOICE OF THE PROGRAMME NUMBER

Note: the F26 SPEED instrument as 8 programs maximum.

3. TEST TYPE SELECTION

Three test types are available: leak test (**LEAK**), pressure test (**P MODE**) and desensitized test (**D MODE**); see the following paragraph for explanations.

3.1. LEAK TEST (LEAK)

The leak test is most suitable for measuring small leaks (pressure drop).

The following formula is used to convert a leak expressed in units of flow to a drop in pressure.

$F(\text{cm}^3/\text{min})$ = Leak flow
 $V(\text{cm}^3)$ = Volume of the test part
 $\Delta P(\text{Pa/s})$ = Pressure drop

$$\Delta P(\text{Pa/s}) = \frac{F(\text{cm}^3/\text{min})}{0,0006 \times V(\text{cm}^3)}$$

Example:

| Part which has $dP/dt = 50 \text{ Pa/s}$ | | | Part which has $dP/dt = 1 \text{ Pa/s}$ | | |
|--|------|------|---|------|----|
| Test | Pa/s | Pa | Test | Pa/s | Pa |
| 1 s | 50 | 50 | 1 s | 1 | 1 |
| 2 s | 50 | 100 | 2 s | 1 | 2 |
| 3 s | 50 | 150 | 3 s | 1 | 3 |
| . | . | . | . | . | . |
| . | . | . | . | . | . |
| n s | 50 | nx50 | n s | 1 | n |

The choice of working in Pa or in Pa/s depends on the application.

In all events, it must not be forgotten that the full scale of the sensor in Pa or Pa/s is limited to 50, 500 or 5000 Pa depending on the instrument configuration.

3.2. BLOCKAGE TEST MODE (P MODE)

The blockage mode is used for rough measurement of a flow, based on the measurement of back pressure. The standard pressure limits are used to classify the results as good or bad.

The cycle only contains the fill phase and the measurement is carried out during this phase.

If the pressure measured is below the minimum limit, then the flow is too large.

If the pressure measured is in excess of the maximum limit, then the flow is too small.

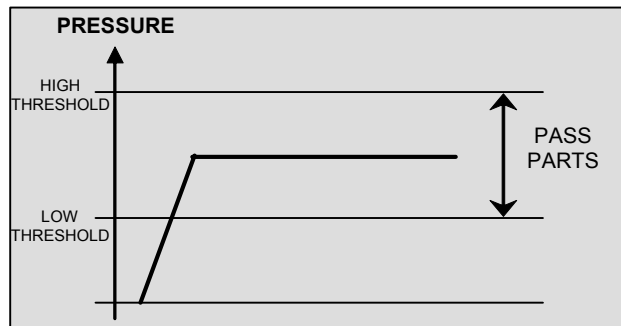

3.3. DESENSITIZED MODE TEST (D MODE)

This mode is used for the measurement of large leaks, when the reject level required is above 500 Pa.

The unit used during the reading of the pressure drop in desensitized mode is the unit which is used for the display of the test pressure (identical resolution). The limits will also be indicated in this unit.

4. PARAMETERS ADJUST

See the Winateq software user manual.

4.1. WAITING TIME (WAIT A)

The waiting time A is top cycle parameter.

4.2. FILL TIME (FILL TIME)

This is the time allowed for the pressurization of the part to be tested. It must not be too long (waste of time) or too short (the pressure in the component is at risk of not being sufficient due to drops in pressure caused by temperature changes).

4.3. STABILIZATION TIME (STAB)

This time is used to stabilize the pressure in the test circuit.

It is possible that a change in pressure occurs due to thermal exchanges between the components. If the instrument takes a measurement too early, the instrument will indicate the presence of a large leak.

- ✓ To determine the correct stabilization time, it is necessary to set a long time so that the reading at the end of the test time is equal to zero.
- ✓ Set the stabilization time to four times the length of the fill time.
- ✓ Carry out a cycle. When the instrument switches to the test period, the pressure must remain at zero.
- ✓ If the pressure is stable, the stabilization time is therefore too long. Progressively shorten and carry out cycles until you see the appearance of a drop in pressure. This indicates that the stabilization time has become too short. Increase it slightly.

4.4. TEST TIME (TEST)

The test time depends on the programmed reject level and operation mode.

In the dP/dt (Pa/s) mode, the variation in measured pressure is due to the drift in the pressure drop.

In the dP (Pa) mode, the pressure variation measured is the total of the pressure drop over the whole test time. This mode is more unstable, but is more sensitive. The instrument totals all the variations occurring due to variations in volume or temperature over the whole of the test time.

4.5. DUMP TIME (DUMP)

The instrument will as default propose a dump time of zero. This must be set by carrying out several tests.

4.6. PRESSURE UNIT (PRESSURE UNIT)

The different units are: bar, mbar, PSI, Pa, kPa, MPa. .

4.7. MAXIMUM FILL (MAX FILL)

This function is used to set a maximum limit for the fill pressure. A warning is triggered if this limit is exceeded.



When test time is infinite, the maximum fill pressure monitoring is inoperative. Care should therefore be taken to avoid excess pressure being applied to the part during the test.

4.8. MINIMUM FILL (MIN FILL)

This function is used to set a minimum limit for the fill pressure. A warning is triggered if this limit is not reached.

4.9. REJECT UNIT (REJECT UNIT)

The different reject units available are: bar, Pa, Pa/s, kPa, KPa/s, cm³/min.

4.10. TEST REJECT (REJECT MAX)

This function is used to set a limit level below which the part is considered to be bad.

4.11. PRE FILL (PRE FILL)

The pre-fill function is used in three fields of application:

- ✓ large volume part test : to fill the part faster in order to reduce the cycle time (without pre-fill time),
- ✓ test on parts requiring a mechanical constraint so that they remain stable for the duration of the test,
- ✓ part burst tests, where the pre-fill pressure exerts a mechanical constraint similar to that of a mechanical resistance test on the test part.

When this function is validated, three parameters appears:

- ✓ **Pre-fill time (PFILL T.):** allotted time to put under the part test in the pre-fill step.
- ✓ **Pre-dump time (PDUMP T.):** allotted time for the part pre-dump before the filling to the test pressure (useful if the pre-fill pressure value is greater than the test pressure). To keep the part under pressure, set this parameter to 0.
- ✓ **Maximum pre-fill pressure (MAX PFILL):** this function is used to set the maximum pre-fill pressure level. An alarm is triggered if this limit is exceeded.

4.12. RECOVERIES LIMITS (THRESHOLD RECUP.)

This option offers the option of two reject (FAIL) levels: non-tolerance level (the bad part cannot be worked on) and a re-workable reject level (the part is bad but may be reworked to become acceptable. This option is particularly used in casting, when parts may be treated via impregnation.)

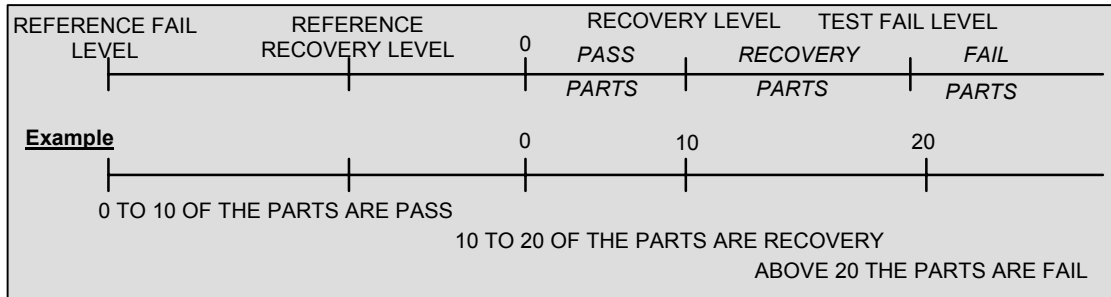

For re-workable parts, with multi-head configuration on the central unit or on the heads themselves, the Pass (POK) and Fail (NOK) outputs are both activated simultaneously.

Note: when the recoverable reference reject value is zero, the program uses the symmetrical absolute value of the recoverable test reject (e.g.: if the recoverable test reject is 10 Pa, then with the recoverable reference reject value equal to zero, the program takes the recoverable reference reject to be – 10 Pa).

4.13. END OF CYCLE FUNCTION

If the part is OK, the PASS part relay will be activated as soon as the test ends and remain so until the start of the following cycle. Following the dump time, the end of cycle relay is activated.

If the part is fail, see the following options.

4.13.1. End of cycle function not validated

If the part is fail, the FAIL part relay is activated as soon as the test is completed. The instrument automatically dumps and sends a cycle end signal. A new cycle can then be launched.

4.13.2. Function validated with dump option

If the part is Bad, as soon as the test time is over, the FAIL part relay is activated and remains so until the end of the cycle. The dump is then carried out.

The cycle can be ended by pressing the **RESET** key or by activating the **RESET** input.

4.13.3. Function validated with the fill option

If the part is bad, as soon as the test time is finished the FAIL part relay becomes and remains activated.

The instrument waits for a reset from the operator or the PLC to start the dump time and send the end of cycle signal.

4.14. TRANSIENT ATTENUATION (ATR)

✓ **Problem:**

Is this pressure drop which occurs during the test time due to a leak or a transient effect?

The test environment is not always ideal for the measurement of pressure drops. There are several momentary events (ex: temperature or volume variations...) that can influence the measurement. We call them transient effects.

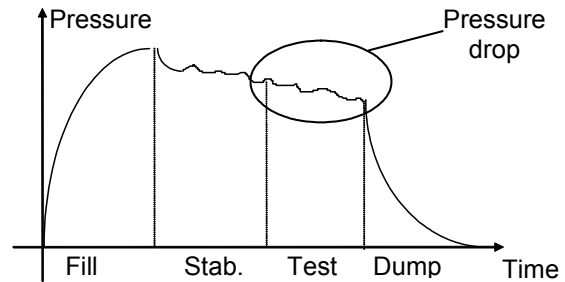

To avoid any interference, it is possible to increase the stabilization time to obtain the ideal measurement conditions during the test phase. However, increasing the stabilization time for each test may not be acceptable at the normal production speed.

Operational principle: The principle consists of measuring the pressure variations caused by transient phenomena through the use of a learning cycle and then removing these variations from the final test result for a part.

When this function is validated four parameters appears:

- ✓ **Start (START):** start value of the transient,
- ✓ **Transient (TRANS.):** transient current value, not editable
- ✓ **Drift (DRIFT):** drift tolerance during the transient acquisition, reject level value percent, when the transient is over this value, an alarm is triggered.
- ✓ **Tolerance (TOLER.):** reject level value percent which the measurements results are taken account for the transient calculation.

Transient drift: Due to the evolution of the test conditions (temperature variations...), the value of the transient can vary through time. It is therefore necessary to track its evolution.

To avoid having to carry out learning cycles too often, the **ATEQ** instrument saves the last ten values of parts considered as very good (result close to 0) and recalculates the transient using the average value.

The parts are considered as very good when their leak rate is lower than the “percentage drift” value of the reject (FAIL) level. This value can be modified between 0 % and 100 %.

$$\text{Transient} = \frac{\sum \text{of the value of the last 10 very good parts}}{10}$$

⚠ The transient attenuation (ATR) can only be used on parts which behave in very similar ways during the test, in other words, parts which generate similar transients.

The **ATR** error appears if the difference between the transient and the initial (start) value is greater than the reject (FAIL) level.

The transient can evolve one way or the other; therefore it is preferable to have identical Test and Reference reject levels.

4.15. PROGRAM SEQUENCING

This function enables several tests to be carried out by the instrument one after the other. The instrument offers 8 program sequencing criteria.

The sequencing order can be edited; the choice of the following program is defined in the parameters. By default the programs are sequenced according to their original number P+1.

- ✓ **Cycling program (CYCLING PROG.):** to indicate the following program in the sequence.
- ✓ **Inter cycle (INT. CYC.):** waiting time between two sequenced programs.
- ✓ **Cycling conditions:** all parts (ALL PARTS); pass parts (PASS PART); fail parts (FAIL PART).

4.16. PERMANENT DUMP

The "**Permanent dump**" mode can be used in some cases to avoid the over pressures carried out by caps installation.

This mode opened the dump valve during the total rest step. It be closed at the start of the fill time, during the stabilization time and will be opened at the end of the test time.

The dump time can be configured, to give the end cycle message and take in account the "**Dump threshold**" function when activated.

When the "**Permanent dump**" function it not validated, the normal dump is by default selected.

4.17. SYSTEM SETTINGS

The **SYSTEM SETTINGS** menu gives access to the extended parameters.

To configure these parameters, see the chapter 4.

5. DUPLICATION OF A TEST PROGRAM

See the Winateq software user manual.

6. DELETING A PROGRAM OR A PROGRAM NAME

See the Winateq software user manual.

7. STARTING A CYCLE

See the Winateq software user manual.

8. STARTING A MEASUREMENT CYCLE

The start cycle can be done following two types: either from the Winateq software (see the Winateq software user manual), either from the input 2 of the I/O connector.

9. STOPPING A CYCLE

The stop cycle can be done following two types: either from the Winateq software (see the Winateq software user manual), either from the input 1 of the I/O connector.

10. TEST PRESURE ADJUST

The **ATEQ F26 SPEED** instrument has no pressure regulator; the input pressure must be adjusted at the test pressure value. However it's possible to start the regulator adjust special cycle (reg adj) to display the test pressure and adjust it on the external regulator.

Chapter 4

FUNCTIONS OF THE INSTRUMENT

1. MENU STRUCTURE

1.1. MAIN MENU

| MAIN MENU | Under menu 1 | Under menu 2 |
|-------------------|----------------------|---|
| EDITION PROGRAMME | Pr 01 to Pr 08 | |
| V | | |
| TYPE TEST | ----- | |
| V | LEAK TEST | |
| V | MODE D | |
| V | MODE P | |
| V | | |
| WAIT A | 0 to 650 s | |
| V | | |
| FILL TIME | 0 to 650 s | |
| V | | |
| STAB | 0 to 650 s | |
| V | | |
| TEST | 0 to 650 s | |
| V | | |
| DUMP | 0 to 650 s | |
| V | | |
| PRESSURE UNIT | MPa | |
| V | Bar | |
| V | mbar | |
| V | PSI | |
| MAX FILL | | |
| V | | |
| MIN FILL | | |
| V | | |
| THRESHOLD RECUP. | No / Yes | Recovery value |
| V | | |
| REJECT UNIT | Pa | |
| V | Pa/s | |
| V | kPa | |
| V | kPa/s | |
| V | Cm ³ /min | |
| V | | |
| TEST REJECT | Reject value | |
| V | | |
| PRE FILL | No / Yes | |
| V | | |
| PFILL T. | 0 to 650 s | Only if the PRE FILL parameter is validated |

| MAIN MENU | Under menu 1 | Under menu 2 | |
|-----------------|--|---|--|
| V | | | |
| PDUMP T. | > 0 to 650 s | | Only if the PRE FILL parameter is validated |
| V | | | |
| MAX FILL | Maximum pressure level. Only if the PRE FILL parameter is validated | | |
| V | | | |
| END OF CYCLE | > No / Yes | | |
| V | | | |
| MODE | > FILL DUMP | | Only if the END OF CYCLE parameter is validated |
| V | | | |
| ATR 0 | > No / Yes | | |
| V | | | |
| CYCLING | > No / Yes | | |
| V | | | |
| CYCLING PROG. | > Pr 01 to Pr 08 | | Only if the CYCLING parameter is validated |
| V | | | |
| INT. CYC. | > 0 to 650 s | | Only if the CYCLING parameter is validated |
| V | | | |
| ALL PART | > No / Yes | | |
| V | | | |
| PASS PART | > No / Yes | | |
| V | | | |
| FAIL PART | > No / Yes | | |
| V | | | |
| SYSTEM SETTINGS | > Dump Threshold | > On / Off | |
| | V | | |
| | Press unit | > MPa Bar mbar PSI | |
| | V | | |
| | V | | |
| | V | | |
| | V | | |
| | Pressure | Dump level value | |
| | V | | |
| | Input 6 | > None Reg. Adj. Inf. Fill Piezo AZ Auto test | If one of these function is used, it doesn't appear in the other input selection |
| | V | | |
| | V | | |
| | V | | |
| | V | | |
| | V | | |
| | Input 7 | > None Reg. Adj. Inf. Fill Piezo AZ Auto test | If one of these function is used, it doesn't appear in the other input selection |
| | V | | |
| | V | | |
| | V | | |
| | V | | |

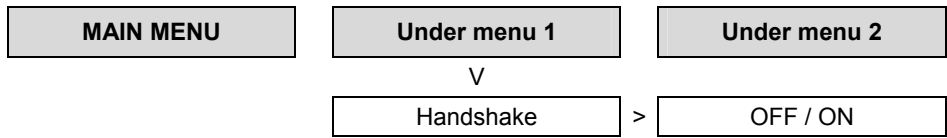

1.2. SPECIAL CYCLE MENU

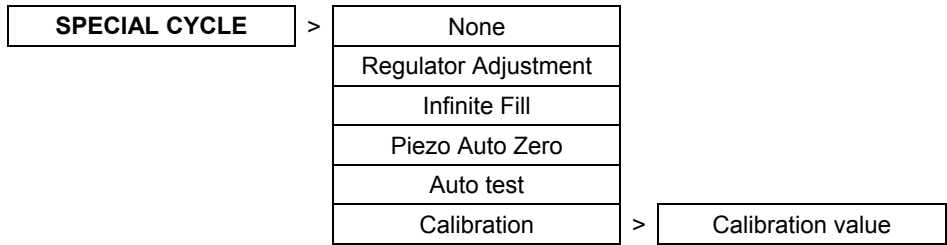

2. SYSTEM SETTINGS

The system settings menu (SYSTEM SETTINGS) allows configuring the instrument.

2.1. DUMP LEVEL

Dump monitoring function, the instrument don't gives the cycle end status if at the end of the dump time the pressure of the tested part is higher than the configured threshold.

2.2. INPUTS 6 AND 7 CONFIGURATION (IN6 / IN7)

This menu is used to configure programmable inputs 6 (pin 8) and 7 (pin 9) on the I/O connector.

Refer to Chapter 1, paragraph 2.3.2.2) "I/O Connector (I/O Inputs/Outputs) programmable input".

The various functions which can be set on input 6 or 7 are: "**Valve Auto-test**", "**Regulator adjust**", "**Infinite fill**", "**Piezo auto zero**".

These functions represent all the special cycles available.

NB: to activate one of these functions, it must activate the input 6 (IN6) or input 7 (IN7) and activating simultaneously the "Start" input.



If the current run program is not created, none of these function appears in the "**I/O Configuration**" menu, only the program selection menu is accessible.

2.3. HANDSHAKE

This function is used for the RS232 link.

It allows sending or keeping the frames in case of the receiver instrument (for example a PC) is not available to receipt the frames at this time.

If the **HANDSHAKE** function is validated, the ATEQ instrument will wait an acknowledgement from the receiver for its sent frames, if there's no receipt acknowledgement, it will keep the frames until the receiver will be available.

If the **HANDSHAKE** function is not validated, the ATEQ Instrument will send the frames at each time, whatever the receiver state.

Note: the RS232 serial link properties for this instrument are fixed and the following ones, you should adjust the properties of the receiving device as identical.

57600 bytes/s - 8 bits - 1 stop bit – Parity : Even.

The differents frames for the tests results are the same as the following ones, example for a test with the program number 07:



| | |
|---------------------|--------------------------------------|
| Pass part: | <07>: 409 mbar:(OK): 17 Pa |
| Fail part: | <07>: 407 mbar:(PMT): 33 Pa |
| Alarm low pressure: | <07>: 0 mbar:ALARME:PRESSURE TOO LOW |
| Alarm full scale: | <07>: 401 mbar:ALARME:> FULL SCALE |

3. SPECIAL CYCLES MENU

3.1. SPECIAL CYCLES AVAILABLE

The following list shows all the special cycles which are possible those available will vary depending on what is checked in the expanded menus or according to the optional extras requested at the time of manufacture of the instrument.

| Special cycle | Function |
|-------------------------------|--|
| ✓ Inactive | No special cycle selected. |
| ✓ Regulator adjust | Cycles used to set the regulator. |
| ✓ Infinite fill | Cycle used to put test part under pressure for infinite time. |
| ✓ Piezzo auto reset | Cycle used to carry out forced reset of the piezzo transducer and the electronic regulator. |
| ✓ Calibration check by volume | Cycle started manually by the operator to carry out calibration check by volume with a good part. |
| ✓ Auto test | Allows making a self control internal of the instrument, this is a checking of the no seal of the internal valves. |

To run a special cycle, select it in the "special cycles" menu, then press the  button. To stop it, press the  button. In some cycles the stop is automatic.

3.2. SPECIAL CYCLES STARTING

3.2.1. Regulator adjust

This special cycle enables the main regulator pressure to be set. With Winateq or from a programmable input configured for this function, start the cycle, check or adjust the pressure then stop the cycle.

3.2.2. Infinite fill

It is possible to carry out an infinite fill with the instrument, in other words, a permanent flow of air at the test pressure in order to locate leaks (set-up adjustment...).

If the assembly allows it (risk of sudden disconnection of part under pressure) it is preferable, in the case of infinite fill, to have a dump time of zero so as not to draw in liquid if there is a leak (when looking for leaks using a soapy water based product).

With Winateq or from a programmable input configured for this function, start the cycle, and then stop the cycle

3.2.3. Piezo auto zero

Used for compulsory reset to zero of the piezzo sensor.

With Winateq or from a programmable input configured for this function, start the cycle, at the end the cycle stops itself.

3.2.4. Auto-test

Allows to make an internal self control of the instrument, it's a non presence internals valves leaks checking.

With Winateq or from a programmable input configured for this function, start the cycle, at the end the cycle stops itself, if the auto test is fail, an alarm is triggered.

3.2.5. Calibration

If the measurements units are not appropriate for the application, it's possible to use a custom unit mode (manual). To do this, a learning cycle must be carried out so that a custom unit value will correspond to a pressure drop.

With **Winateq300** software, in the special cycles menu, type the value of the master leak (or the pass part) in the calibration instruction (**CALIB. VALUE**) then select the special calibration cycle and start it (**START**). On these outputs we have :

- **"Pass part"** and **"End of cycle"** if the target is lower than or equal to the FAIL reject level,
- **"Fail part"** and **"End of cycle"** if the target is greater than the test FAIL level.

The measured leak will correspond to the entered value.

Chapter 5

ACCESSORIES

1. OPTIONAL ACCESSORIES

1.1. NEEDLE VALVE AND LEAK/FLOW CALIBRATOR (CDF)

1.1.1. Needle valve

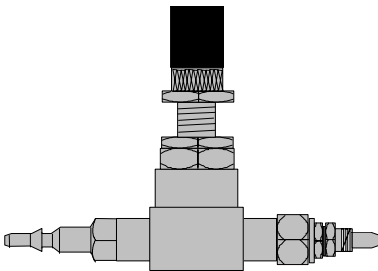

Needle valves are used to calibrate the leakage limits. These valves have an adjustable leak and depending on the model allow adjustments of between a few cm³/h to several l/min.

These valves can be easily disturbed and therefore require the frequent use of some means of checking the setting (ex: CDF).

Note: it is strongly recommended that you do NOT leave a needle valve permanently connected on a leak detection machine with automatic calibration every "n cycles".

1.1.2. CDF (Leak/flow Calibrator)

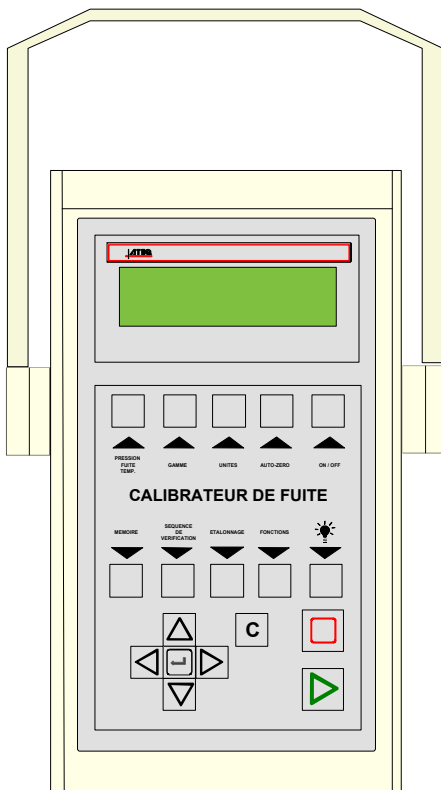

The **Leak/Flow calibrator** is a multiple range **ATEQ** flow meter intended for checking leak testing equipment and particularly **ATEQ** instruments. It measures a loss of charge with a differential sensor, which is connected to a calibrated flow tube.

1.2. CALIBRATED LEAK

Calibrated leaks are used to check the instrument's calibration.

| PRESSURE | Master leak type | | | | | | | | | | |
|-----------------------------|------------------|-----|------|------|------|-----|------|------|------|------|------|
| | A | B | 5 | C | D | 50 | E | F | G | 1000 | 5000 |
| 2 kPa (20 mbar) | | | 1,5 | 3,12 | 6,6 | 18 | 31,2 | 1,24 | 2,05 | 4,2 | 53 |
| 5 kPa (50 mbar) | | 2,3 | 4 | 7,4 | 17,5 | 42 | 1,3 | 2,6 | 5,25 | 11,3 | 132 |
| 15 kPa (150 mbar) | 2,82 | 6,7 | 12 | 23 | 55 | 2,2 | 4 | 8,2 | 17 | 35,5 | 338 |
| 30 kPa (300 mbar) | 4,8 | 12 | 24 | 46,8 | 2,12 | 3,6 | 7,6 | 22,4 | 40 | 74,5 | 700 |
| 50 kPa (500 mbar) | 10 | 25 | 48 | 1,4 | 3,5 | 8 | 15,5 | 31 | 63 | 150 | 1142 |
| 100 kPa (1 bar) | 23 | 56 | 1,8 | 3,3 | 8 | 19 | 37 | 74 | 149 | 360 | 2230 |
| 200 kPa (2 bar) | 55 | 2,3 | 4,6 | 8,5 | 21 | 47 | 89 | 194 | 380 | 830 | 4343 |
| 400 kPa (4 bar) | 2,5 | 6,6 | 12,1 | 23,3 | 56 | 125 | 220 | 540 | 1030 | 1500 | 8750 |
| 1 MPa (10 bar) | 11,5 | 29 | 50 | 95 | 198 | 420 | 705 | 2310 | 3700 | 4450 | |

 **kPa.cm³/h**
(bar.cm³/h)

 **kPa.cm³/min**
(bar.cm³/min)

Note: the values indicated above are given for information and can vary by +/- 20%. The true rate is precisely measured before delivery with an accuracy of +/- 5% up to 1Mpa.cm³/min (10 bar.cm³/min) and +/- 3% from this value. **Special master leaks can be manufactured on request, within 5% of the requested value.**

- ✓ The calibrated leaks must be used with clean dry air.
- ✓ These leaks must not be dipped in water. It is essential that they are stored in their case after usage.
- ✓ The leaks must be checked periodically by the company's metrology department or by **ATEQ's** metrology service.
- ✓ Check that there is an O-ring seal and that it is in good condition.
- ✓ The instrument zero check must be done by replacing the leak with a sealing connector and not by sealing off the leak itself.
- ✓ To check that the leak has not been blocked, attach a piece of flexible tubing to the leak and submerge its extremity in water to watch for bubbles.

1.3. POWER SUPPLY

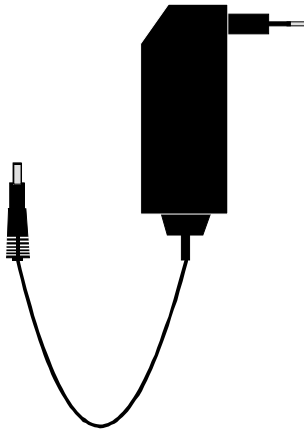

The power supply of the **F26 SPEED** converts a network voltage (120 to 240 V AC) into a 24 V DC low voltage supply. It has no power switch and works as soon as it is plugged in. It is protected against surges and short circuits via a thermal fuse (Do not use any other type of fuse).

1.4. FILTRATION KIT

Clean, dry air must be used to ensure the reliability of the instruments.

It consists of a dust filtering cartridge (5µm) and other cartridge (0.01 µm) giving residual oil pollution equal to 0.01 ppm.

1.5. MICRO VALVE (OPTION)

The micro valve is an option ordered at the manufacture of the device, a connector is add for driving an external valve which allows, for example : external dump, automatic connector, Y valve, etc....

Note: for mechanical reaction time reasons, the filling and dump times should not be less than 20 ms. It's important to not configure these parameters below this value.

1.5.1. Micro valve connector

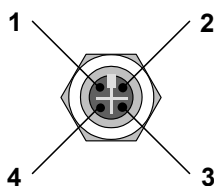

M12 connector 4 pins female, to connect the micro valve option.

This micro valve can have several functions following its configuration. External dump or valve code, the use of one mode excluding obligatory the other.

The configuration of this valve is only done from the **Winateq300** software.

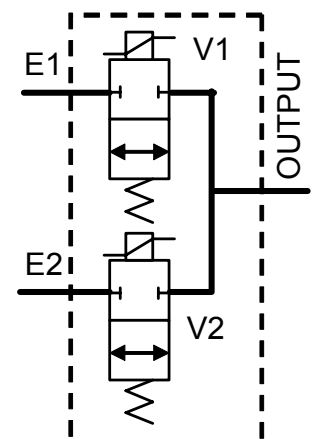

1.5.2. "External dump" installation

External dump: to reduce the dump time or avoid dump through the **ATEQ F26 SPEED** device.

The valve will be installed between the part to test and the **ATEQ F26 SPEED** device.

This kind of installation can be used too, for example, to eject a vacuum test part at the end of cycle.

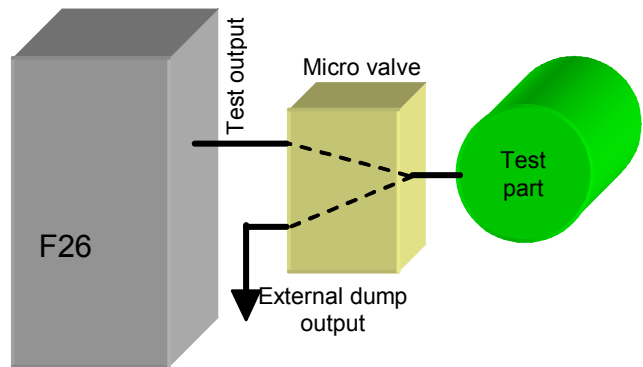

1.5.2. 1) Configuration with *Winateq300*

With *Winateq300* it must validate the "External Dump" option (the "Valve Code" option is deactivate).

| | |
|----------------|-------------------------------------|
| EXTERNAL DUMP: | <input checked="" type="checkbox"/> |
| VALVE CODE: | <input type="checkbox"/> |
| → CYCLE VALVE: | <input type="checkbox"/> |
| → EXTERNAL A: | <input type="checkbox"/> |
| → EXTERNAL B: | <input type="checkbox"/> |

1.5.2. 2) Timeline

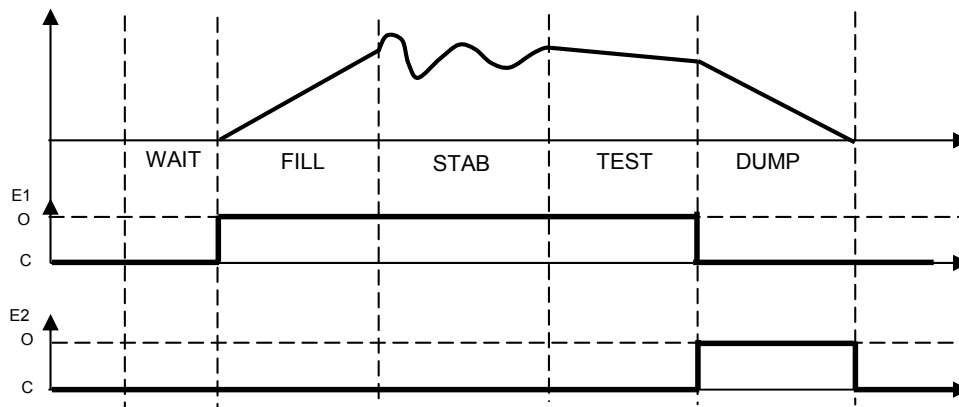

1.5.3. "Valve code "installation

Valve code: this function can be used to have two test pressures (double regulation) or to tester two parts the one after the other (Test1/Test2).

1.5.3. 1) Double regulation

The valve is used to switch two different tests pressures on the **ATEQ F26 SPEED** device input.

The **E1** (External A) and **E2** (External B) inputs are used or not following the program number.

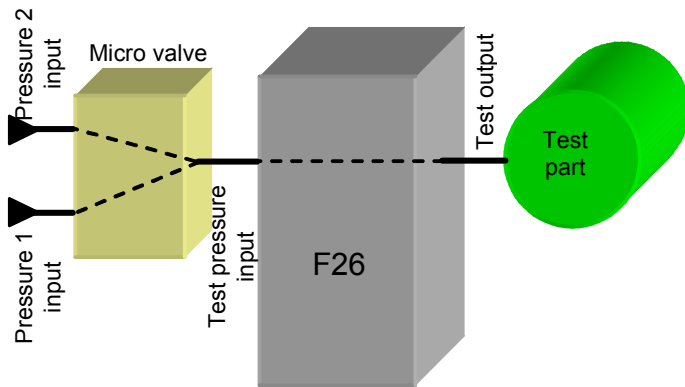

a) Configuration with Winateq300

With **Winateq300** it must validate the **"Valve Code"** option (the **"External Dump"** option is deactivated). Validate the **E1** (External A) or **E2** (External B) inputs in the test program to select the test pressure.

| | |
|----------------|-------------------------------------|
| EXTERNAL DUMP: | <input type="checkbox"/> |
| VALVE CODE: | <input checked="" type="checkbox"/> |
| CYCLE VALVE: | <input type="checkbox"/> |
| EXTERNAL A: | <input checked="" type="checkbox"/> |
| EXTERNAL B: | <input type="checkbox"/> |

The **"External A"** and **"External B"** outputs can't be drive at the same time, they are in **XOR**.

The **"Cycle Valve"** option, when validate, activate the valve during the test cycle and deactivate the valve at the end of the dump. If it not validate, the valve is activated since the start cycle and remains activate. It will be deactivated at the start of the following program if it the other valve.

1.5.3. 2) Timeline

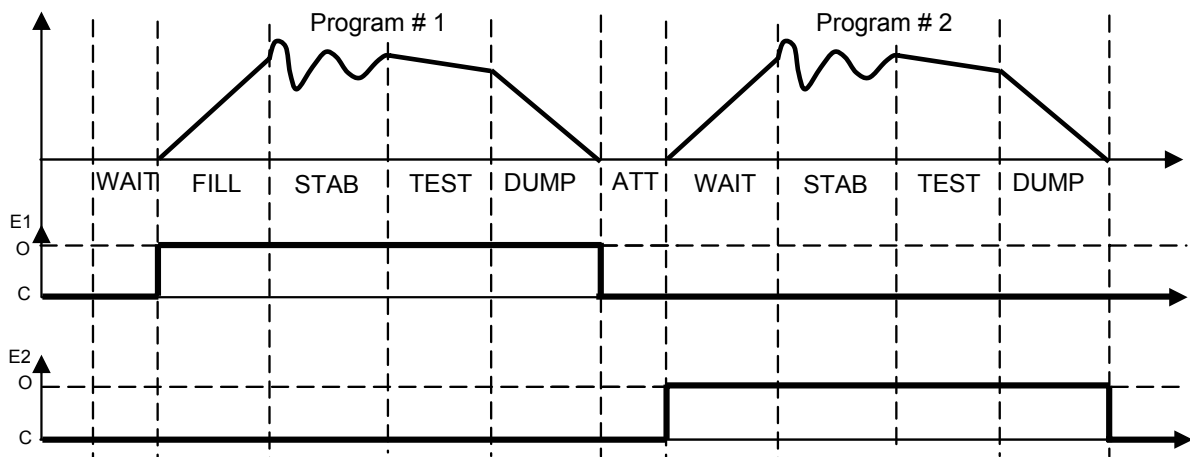

1.5.3. 3) T1 / T2 Function

The valve is used to switch to a part or the other.

The **E1** (External A) and **E2** (External B) inputs are used or not following the program number.

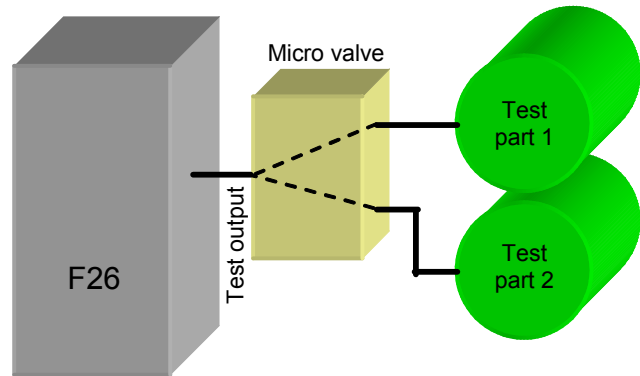

a) Configuration with Winateq300

With **Winateq300** it must validate the "**Valve Code**" option (the "**External Dump**" option is deactivate). Validate the **E1** (External A) or **E2** (External B) inputs in the test program to select the test part.

| | |
|----------------|-------------------------------------|
| EXTERNAL DUMP: | <input type="checkbox"/> |
| VALVE CODE: | <input checked="" type="checkbox"/> |
| CYCLE VALVE: | <input type="checkbox"/> |
| EXTERNAL A: | <input checked="" type="checkbox"/> |
| EXTERNAL B: | <input type="checkbox"/> |

The "**External A**" and "**External B**" outputs can't be drive at the same time, they are in **XOR**.

The "**Cycle Valve**" option, when validate, activate the valve during the cycle and deactivate it at the end of the dump. If it's not validated, it's activated since the test start and remains activate. . It will be deactivated at the start of the following program if it used the other valve.



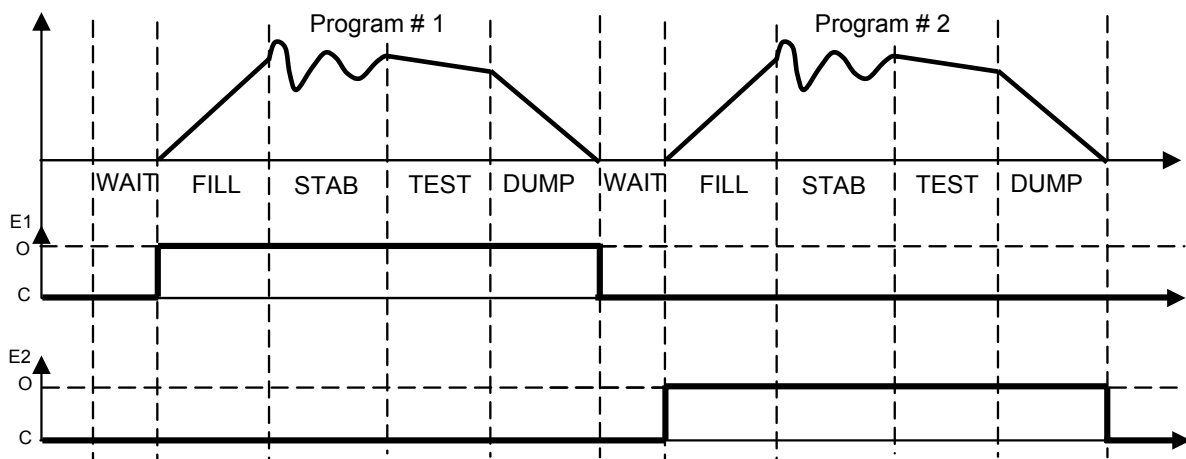

1.5.3. 4) Timeline



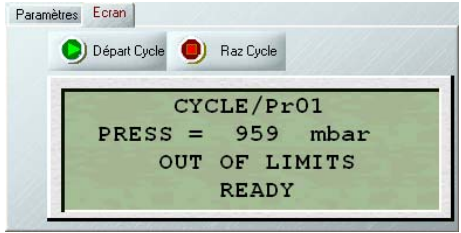

Chapter 6

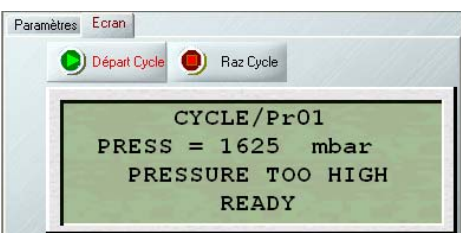
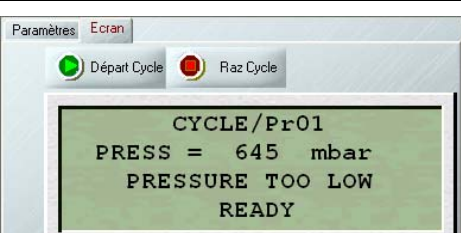
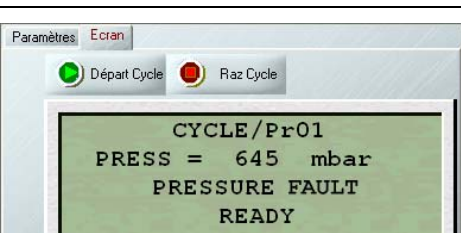
ERROR MESSAGES

The **ATEQ F26 SPEED** can display error messages if there are operational problems.

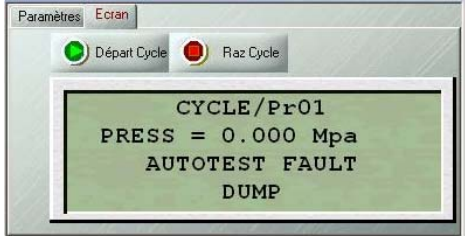
| PROBLEM | MESSAGE DISPLAY IN THE WINATEQ SOFTWARE |
|--|--|
| <p>OUT OF LIMIT</p> <p>Leak greater than the full scale. Action: check the test circuit.</p> |  |
| <p>> FULL SCALE</p> <p>Pressure greater than the full scale. Action: decrease the test pressure supply.</p> |  |
| <p>PRESSURE TOO HIGH</p> <p>Pressure greater than the maximum level. Action: check the supply pressure value and the pressure thresholds..</p> |  |
| <p>PRESSURE TOO LOW</p> <p>Pressure lower than the minimum level. Action: check the supply pressure value and the pressure thresholds.</p> |  |
| <p>PRESSURE FAULT</p> <p>This message indicates that the test pressure is out of the area set by the minimum and maximum limits during the Stabilization step. Action: check the test circuit.</p> |  |
| <p>ATR ERROR</p> <p>ATR fault. Action: check the ATR parameters ATR.</p> |  |

| PROBLEM | MESSAGE DISPLAY IN THE WINATEQ SOFTWARE |
|---|---|
| <p style="text-align: center;">DISCONNECTED</p> <p>The link between the F26 SPEED and the PC break. Action: check the USB or RS232 connection.</p> |  <p>The screenshot shows the WinATEQ software interface with a green background and the text 'DISCONNECTED' in the center. At the top, there are buttons for 'Départ Cycle' (with a green circle) and 'Raz Cycle' (with a red circle).</p> |
| <p style="text-align: center;">AUTOTEST FAULT</p> <p>Auto test fault. The internal valve as an important fault has excessive seal. Action: check the cap on the test output, if the problem persist, the valve have a big leak and must be repaired or replaced. .</p> |  <p>The screenshot shows the WinATEQ software interface with a green background and the text 'CYCLE/Pr01', 'PRESS = 0.000 Mpa', 'AUTOTEST FAULT', and 'DUMP' in the center. At the top, there are buttons for 'Départ Cycle' (with a green circle) and 'Raz Cycle' (with a red circle).</p> |
| <p style="text-align: center;">SYSTEM ERROR</p> <p>An instrument internal fatal error appears. Action: this fault may never appear. Else restart the instrument and if the problem persists, contact the ATEQ after sale service.</p> |  <p>The screenshot shows the WinATEQ software interface with a green background and the text 'SYSTEM ERROR' in the center. At the top, there are buttons for 'Départ Cycle' (with a green circle) and 'Raz Cycle' (with a red circle).</p> |

Pressure faults resume:

| PRESSURE RANGE | FILL | STABILIZATION |
|------------------------|------------------------|------------------------|
| > Full Scale | PRESSURE OUT OF LIMITS | PRESSURE OUT OF LIMITS |
| > Maximum reject level | PRESSURE TOO HIGH | PRESSURE FAULT |
| < Minimum reject level | PRESSURE TOO LOW | PRESSURE FAULT |
| < Minimum detectable | PRESSURE OUT OF LIMITS | PRESSURE OUT OF LIMITS |

Chapter 7

OPERATIONAL PROBLEMS

1. PHENOMENON NOTED

If a test machine begins to detect too many bad parts (statistically, more than three consecutively), it is advisable to carry out a **check on the whole unit**. The quality of the manufacture and operation of the leak detector should be the last things considered.

1.1. CONDITION OF THE MACHINE'S SEALS

This is the no.1 defect as the seals are subject to high levels of dirt contamination (alumina, shavings). Regular cleaning of the seals is an effective remedy.

1.2. DAMAGED INSTRUMENT SEALS

There is a possibility that the seals may be cut by shavings or worn by repetitive squashing. This can be prevented by regular servicing and replacement of the seals.

1.3. BUMPER PAD

This is a defect which may occur after a certain amount of time as the bumper pads may be worn, or if the pressure settings in the air cylinder are inadvertently disturbed. Check the stability of the measurement and that the bumper pads are correctly installed.

1.4. PNEUMATIC AIR SUPPLY TOO LOW

This anomaly can cause false measurements (large leaks or erratic measurements). The air supply to the cells must be higher than the minimum of 4 bar and it is essential that it is greater than the minimum test pressure of 1 bar. Also check that sealing connectors are being used correctly.

1.5. PNEUMATIC LINK

The link and reference pipes will age and break with time. The pipes and seals must conform to the required quality. **ATEQ** recommends the use of RILSAN PA11 pipes and AVS type joints.

1.6. ENVIRONMENT

A measurement may be affected by a variation in background temperature (sun, draughts, storage of parts outdoors, handling of the test part by the operator, ...).

The dampness of parts may cause errors in the readings (insufficient drying after washing, outdoor storage, condensation, presence of water in the fixture, ...).

1.7. CALIBRATION

ATEQ does not accept any liability in regard to calibrations and settings to its instruments which are not carried out by its own personnel.

1.8. CONCERNS ABOUT RELIABILITY OF THE INSTRUMENT'S CIRCUITS

If all the other checks do not resolve the problem, the instrument's circuit may be checked.

Proceed as follows:

- ✓ Segregate the instrument from its environment (pneumatic assembly),
- ✓ Connect up the instrument (test output),
- ✓ Choose an unused program,
- ✓ Set the parameters as follows:
 - ⇒ the regulator to the test pressure,
 - ⇒ the pressure monitoring thresholds to +/- 20 % of the test pressure,
 - ⇒ wait times A and B 0 seconds,
 - ⇒ fill time 4 seconds,
 - ⇒ stabilisation time 10 seconds,
 - ⇒ test time 10 seconds,
 - ⇒ dump time 1 second,
 - ⇒ reject level maximum,
 - ⇒ unit Pa/sec,
 - ⇒ function all functions cancelled.

Run two consecutive cycles.

The post test time result should not exceed 4 Pa/sec.

Appendices

ATEQ F26 SPEED

1. F26 SPEED TECHNICAL CHARACTERISTICS

| F26 SPEED | |
|--|---|
| Case dimensions H x L x D (mm) : | 149,50 x 84,5 x 84,5 |
| Electric supply: | 24 VDC / 1,6 A Min 23,5 V ; Max 28 V |
| Pneumatics connections: | M5 |
| Weight (g) : | About 1250 |
| Temperatures : | |
| Operational : | +10°C to +45°C |
| Storage : | 0°C to +60 °C |

2. MECHANICAL DEFINITION DRAWINGS

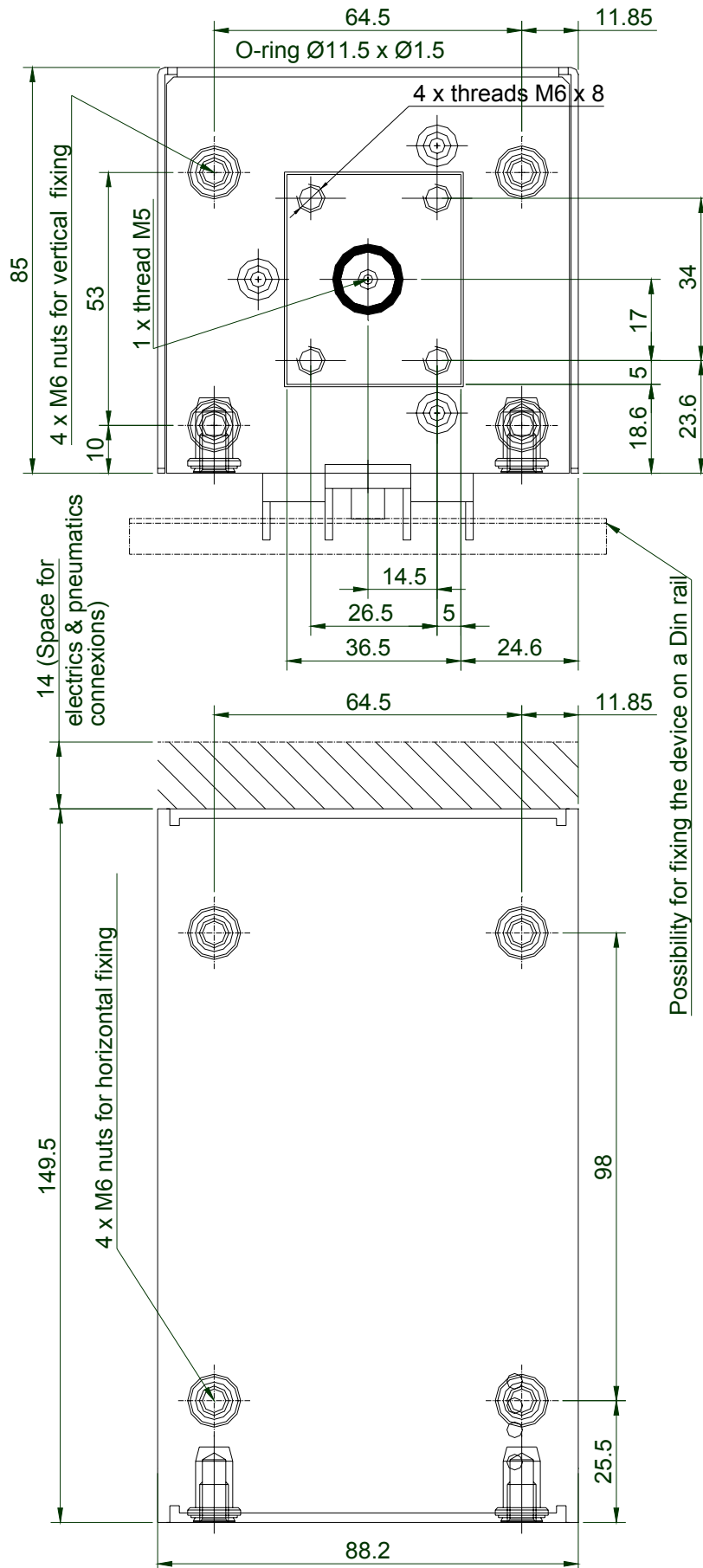

3. CONVERSION TABLE

| | | TO | | | | | | | | | |
|------|-------|-----------------------|-------------------------|-------------------------|-------------------------|---------|-------------------------|-------------------------|-------------------------|------------------------|------------------------|
| | | Pa | kPa | bar | mbar | mmH2O | atm | Torr | psi | inH2O | inHg |
| FROM | Pa | 1 | 10 ⁻³ | 10 ⁻⁵ | 10 ⁻² | 0.10197 | 9.8692 10 ⁻⁶ | 7.5 10 ⁻³ | 1.45 10 ⁻⁴ | 4.01 10 ⁻³ | 2.95 10 ⁻⁴ |
| | kPa | 10 ³ | 1 | 10 ⁻² | 10 | 101.97 | 9.8692 10 ⁻³ | 7.5 | 0.145 | 4.01 | 0.295 |
| | bar | 10 ⁵ | 10 ² | 1 | 10 ³ | 10197 | 0.98692 | 750 | 14.5 | 401.46 | 29.53 |
| | mbar | 10 ² | 10 ⁻¹ | 10 ⁻³ | 1 | 10.197 | 9.8692 10 ⁻⁴ | 0.75 | 1.45 10 ⁻² | 0.401 | 2.95 10 ⁻² |
| | mmH2O | 9.806 | 9.8067 10 ⁻³ | 9.8067 10 ⁻⁵ | 9.8067 10 ⁻² | 1 | 9.6784 10 ⁻⁵ | 7.3556 10 ⁻² | 1.4223 10 ³ | 3.937 10 ⁻² | 2.895 10 ⁻³ |
| | atm | 1.013 10 ⁵ | 101.33 | 1.0133 | 1013.3 | 10332 | 1 | 760 | 14.695 | 406.78 | 29.921 |
| | Torr | 133.32 | 0.13332 | 1.3332 10 ⁻³ | 1.3332 | 13.595 | 1.3158 10 ⁻³ | 1 | 1.9337 10 ⁻² | 0.535 | 3.937 10 ⁻² |
| | psi | 6897.8 | 6.8948 | 6.8948 10 ⁻² | 68.948 | 703.07 | 6.8045 10 ⁻² | 51.71 | 1 | 27.68 | 2.036 |
| | inH2O | 249.09 | 0.2491 | 2.4909 10 ⁻³ | 2.4909 | 25.400 | 2.4583 10 ⁻³ | 1.8683 | 3.61 10 ⁻² | 1 | 7.35 10 ⁻² |
| | inHg | 3386.4 | 3.3864 | 3.3864 10 ⁻² | 33.864 | 345.32 | 3.3421 10 ⁻² | 25.4 | 0.491 | 13.595 | 1 |

Index

| | | | |
|---------------------------------------|----|-------------------------------------|----|
| A | | N | |
| Adjust regulator pressure | 32 | Needle valves | 33 |
| Alarms | 39 | O | |
| ATR | 24 | Out of limit | 39 |
| ATR cycle | 24 | P | |
| ATR explained | 24 | Parameters adjust..... | 21 |
| ATR fault..... | 39 | Permanent dump | 25 |
| Auto test fault..... | 40 | Personal notes..... | 46 |
| B | | Piezo Auto-zero | 32 |
| Blockage mode..... | 20 | PLC connections..... | 13 |
| C | | Pneumatics connectors | 16 |
| Calibration | 32 | Power supply | 35 |
| Calibration leaks | 34 | Pre-fill | 22 |
| Characteristics..... | 4 | Pre-fill time..... | 22 |
| Conversion table..... | 45 | Presentation | 9 |
| D | | Pressure Fault | 39 |
| Definition of the ATEQ F26 SPEED..... | 3 | Pressure high..... | 39 |
| Delete a program..... | 26 | Pressure low..... | 39 |
| Desensitized Mode | 20 | Pressure too high..... | 39 |
| Determine the stabilization time..... | 21 | Pressure units..... | 22 |
| Dimensions..... | 44 | Printer | 15 |
| Direct measurement | 5 | Program Copy..... | 26 |
| Disconnected..... | 40 | Program N° to launch | 26 |
| Dump time | 21 | Programmable input | 12 |
| E | | R | |
| Electrics connectors | 11 | Regulator adjust..... | 26 |
| End of cycle function | 23 | Reject units..... | 22 |
| Ethernet..... | 15 | Rework limits | 23 |
| F | | RS232..... | 15 |
| Fill time | 21 | RS232 frames..... | 30 |
| Filtration kit | 35 | RS232 serial properties | 30 |
| Front face lights | 17 | S | |
| H | | Sequence several test cycles | 25 |
| Handshake | 30 | Special cycle menu | 29 |
| I | | Special Cycles | 31 |
| I/O AoN..... | 11 | Stabilization time..... | 21 |
| I/O configuration | 30 | Start cycle | 26 |
| I/O connector | 11 | Start-up..... | 19 |
| Indirect measurement..... | 5 | Stop cycle | 26 |
| Infinite fill..... | 32 | Symbols..... | 7 |
| Inputs / Outputs | 11 | System error | 40 |
| L | | System settings | 25 |
| Leak mode..... | 19 | T | |
| Leak/Flow calibrator | 33 | Technical characteristics | 43 |
| M | | Test output..... | 16 |
| Maximum fill..... | 22 | Test reject..... | 22 |
| Maximum pre-fill | 22 | Test time | 21 |
| Measurement cycle | 6 | Test types | 19 |
| Menu structure..... | 27 | Transient drift..... | 24 |
| Micro valve | 35 | Transient effects attenuation | 24 |
| Minimum fill..... | 22 | | |

| | | | | |
|-----------|----------|----|---------------------|----|
| | U | | W | |
| USB | | 15 | Waiting time A..... | 21 |

