

**ATEQ F405**  
Version 1.0



**[www.ateq.com](http://www.ateq.com)**

Reference: UM-27100C-U



---

## REVISIONS OF THE ATEQ F405 USER MANUAL

---

<u>Edition/Revision</u>	<u>Reference</u>	<u>Date</u> week/year	<u>Chapters updated</u>
First edition	UM-27100A-U	49/2005	-
Second edition	UM-27100B-U	09/2006	Chapter 4, add function "Dump level" and "Input 5 configuration".
Third edition	UM-27100C-U	17/2007	Modification of the name of the remote control.



# Recommendations for leak testing instruments

## Precautions for the test environment

- Keep the test area as clean as possible.

## Precautions for the operators

- **ATEQ** recommends that the operators using the instruments should have a suitable qualification and training with respect to the work bench requirements.

## General precautions

- Read the user manual before using the instrument,
- all electrical connections to the instrument must be equipped with a safety system (fuse, circuit breaker...) appropriate to its needs and complying with the standards,
- to avoid electromagnetic interference, the cable connections to the instrument should be less than two meters in length,
- it is essential that the electrical main is earthed,
- disconnect the electrical connections to the equipment before maintenance,
- cut the air supply for any kinds of operation on the pneumatic assembly,
- do not open the instrument when it is powered up,
- avoid water spillage near of the instrument,
- **ATEQ** is at your disposal for any further information concerning the use of the instrument under maximum safety conditions.



**We would like to bring to your attention that ATEQ will not be held responsible for any accident connected to the improper use of the instrument, to the work bench or to the lack of compliance with safety rules.**



## **ATEQ, THE ASSURANCE OF A COMPETENT AFTER SALES SERVICE**

### **■ THE ATEQ AFTER SALES SERVICE IS :**

- a team of qualified technicians,
- a permanent telephone assistance,
- agencies close to you for faster reaction,
- a stock of spare parts available immediately,
- a car fleet for rapid intervention,
- a commitment to quality ...

### **■ THE OVERHAUL**

ATEQ carries out the overhaul of your instruments at interesting prices.

The overhaul corresponds to the maintenance of the instrument (checking, cleaning, replacing of used parts) as part of preventive maintenance.

Preventive maintenance is the best way to guarantee reliability and efficiency. It allows the maintenance of a group of instruments in good operational order and prevent eventual break-downs.

### **■ MAINTENANCE KITS**

The ATEQ After Sales Service proposes, two kits destined for the preventive maintenance of the pneumatic circuits of instruments.

### **■ CALIBRATION**

This may be carried out on site or in our offices.

ATEQ is attached to the COFRAC and delivers a certificate following a calibration.

### **■ TRAINING COURSES**

In the framework of partnership with our customers, ATEQ offers two types of training in order to optimise the usage and knowledge of our instruments. They are aimed at different levels of technician:

- method / control training,
- maintenance / upkeep training.

### **■ A TARGETED TECHNICAL DOCUMENTATION**

A number of technical documents are at your disposal to allow you to intervene rapidly in the event minor breakdowns:

- problem sheets describing and offering solutions to the main pneumatic and electronic problems,
- several maintenance manuals.

### **■ A QUALITY GUARANTEE**

The instruments are guaranteed for parts and labour in our offices:

- 2 years for leak detection equipment,
- 1 year for electrical tests to norms instruments,
- 1 year for the accessories.

Our After Sales Service is capable of rapidly answering all your needs and queries.

**ATEQ recommends  
to made realise by its departments  
a revision and a calibration of the instruments  
every year**



## PREFACE

Dear Customer,

You have just purchased an **ATEQ** instrument, we thank you for the trust you have placed on our brand. This instrument has been designed to ensure a long and unparalleled life expectancy, and we are convinced that it will give you complete satisfaction during many long years of operation.

In order to maximise the life expectancy and reliability of your **ATEQ** instrument, we recommend that you install this instrument on a secured workbench and advise you to consult this manual in order to familiarise yourself with the functions and capabilities of the instrument.

Our **ATEQ** After Sales Service centre can give you recommendations based on your specific operation requirements.

**ATEQ**



---

# TABLE OF CONTENTS

---

<b>PREAMBLE</b>	<b>5</b>
1. DEFINITION OF THE ATEQ F405 .....	5
2. MEASUREMENT CHARACTERISTICS.....	6
2.1. Measurement ranges .....	6
2.2. Mechanical pressure regulation .....	6
3. THE MAIN TYPES OF MEASUREMENT .....	7
3.1. Direct/Pressure drop measurement .....	7
3.2. Indirect/Pressure rise measurement .....	7
4. DIRECT MEASUREMENT, PRESSURISATION.....	8
5. SYMBOLS PRESENTATION .....	9
<b>Chapter 1</b>	<b>INSTALLATION OF THE INSTRUMENT</b>
1. APPEARANCE OF THE ATEQ F405.....	11
1.1. Pneumatic case.....	11
1.2. Remote control .....	11
2. INSTALLATION OF THE INSTRUMENT .....	12
2.1. Layout of the connector on the remote control .....	12
2.2. Layout of connectors on the F405 case.....	12
2.3. Electrical connectors details.....	13
2.4. Pneumatics connectors detail .....	17
<b>Chapter 2</b>	<b>USER INTERFACES</b>
1. ATEQ F405 APPEARANCE .....	19
1.1. Pneumatic case.....	19
1.2. Remote control .....	20
2. PNEUMATIC CASE .....	21
2.1. Functions of the indicator lights.....	21
3. REMOTE CONTROL .....	22
3.1. Appearance of the keyboard .....	22
3.2. lockable switch .....	23
3.3. 4 LINE LCD DISPLAY .....	23
<b>Chapter 3</b>	<b>START-UP AND SETTINGS</b>
1. POWERING-UP THE ATEQ F405.....	25
2. CREATION OF A TEST PROGRAM.....	25
2.1. Choice of the program number .....	26
2.2. Test type selection .....	26
2.3. Parameter settings .....	28
3. DUPLICATION OF A TEST PROGRAM .....	32
4. DELETING A PROGRAM OR A PROGRAM NAME .....	34
5. STARTING A CYCLE .....	35
5.1. Choice of the program to be run .....	35
6. STARTING A MEASUREMENT CYCLE.....	35
7. STOPPING A CYCLE .....	36
8. SETTING THE TEST PRESSURE .....	36
8.1. Manual setting with a mechanical regulator.....	36

<b>Chapter 4</b>	<b>FUNCTIONS OF THE INSTRUMENT</b>
------------------	------------------------------------

<b>1. MENU STRUCTURE.....</b>	<b>37</b>
1.1. Main menu.....	37
1.2. "FUNCTIONS" menu when activated.....	40
<b>2. CONFIGURATION MENU .....</b>	<b>42</b>
2.1. Extended .....	42
2.2. RS232 .....	50
2.3. Security .....	53
2.4. Lighting the screen .....	54
2.5. Dump level .....	55
2.6. I/O Configuration .....	56
<b>3. SPECIAL CYCLES MENU.....</b>	<b>57</b>
3.1. Special cycles available .....	57
3.2. Regulator .....	58
3.3. Infinite fill .....	59
3.4. piezzo reset .....	60
3.5. Manual calibration .....	60
3.6. ATR learning .....	62
3.7. Auto-test .....	63
<b>4. MAINTENANCE MENU .....</b>	<b>64</b>
<b>5. RESULTS MENU .....</b>	<b>65</b>
<b>6. LANGUAGE MENU .....</b>	<b>65</b>
<b>7. STAND BY MENU .....</b>	<b>65</b>

<b>Chapter 5</b>	<b>ACCESSORIES</b>
------------------	--------------------

<b>1. ACCESSORIES SUPPLIED WITH THE INSTRUMENT .....</b>	<b>67</b>
1.1. Power supply.....	67
<b>2. OPTIONAL ACCESSORIES.....</b>	<b>68</b>
2.1. Calibrated leak .....	68
2.2. Needle valve and Leak/Flow Calibrator (CDF) .....	69
2.3. Automatic connectors with expandable joints .....	70
2.4. Filtration kit .....	70

<b>Chapter 6</b>	<b>ERROR MESSAGES</b>
------------------	-----------------------

<b>ERROR MESSAGES .....</b>	<b>71</b>
-----------------------------	-----------

<b>Chapter 7</b>	<b>OPERATIONAL PROBLEMS</b>
------------------	-----------------------------

<b>1. PHENOMENON NOTED.....</b>	<b>73</b>
1.1. Condition of the machine's seals .....	73
1.2. Damaged instrument seals .....	73
1.3. Bumper pad.....	73
1.4. Pneumatic air supply too low .....	73
1.5. Pneumatic Link.....	73
1.6. Environment .....	74
1.7. Calibration .....	74
1.8. Concerns about reliability of the instrument's circuits .....	74

<b>Appendices</b>	<b>ATEQ F405</b>
1. TECHNICAL CHARACTERISTICS OF THE F405 .....	75
2. MECHANICAL DEFINITION DRAWINGS OF F405 .....	76
2.1. Pneumatic case.....	76
2.2. Case installation.....	76
2.3. Remote control.....	77
3. CONVERSION TABLE .....	78
4. PARAMETERS STORED .....	79
5. USER NOTES .....	80
<b>Index</b>	<b>81</b>



---

# PREAMBLE

---

## 1. DEFINITION OF THE ATEQ F405

The **ATEQ F405** is a compact air/air leak detector used to test the air tightness of parts on production lines. It is specially adapted for automatic and semi-automatic workbenches. The method used is based on the measurement of a small variation or drop in pressure with a piezzo sensor.

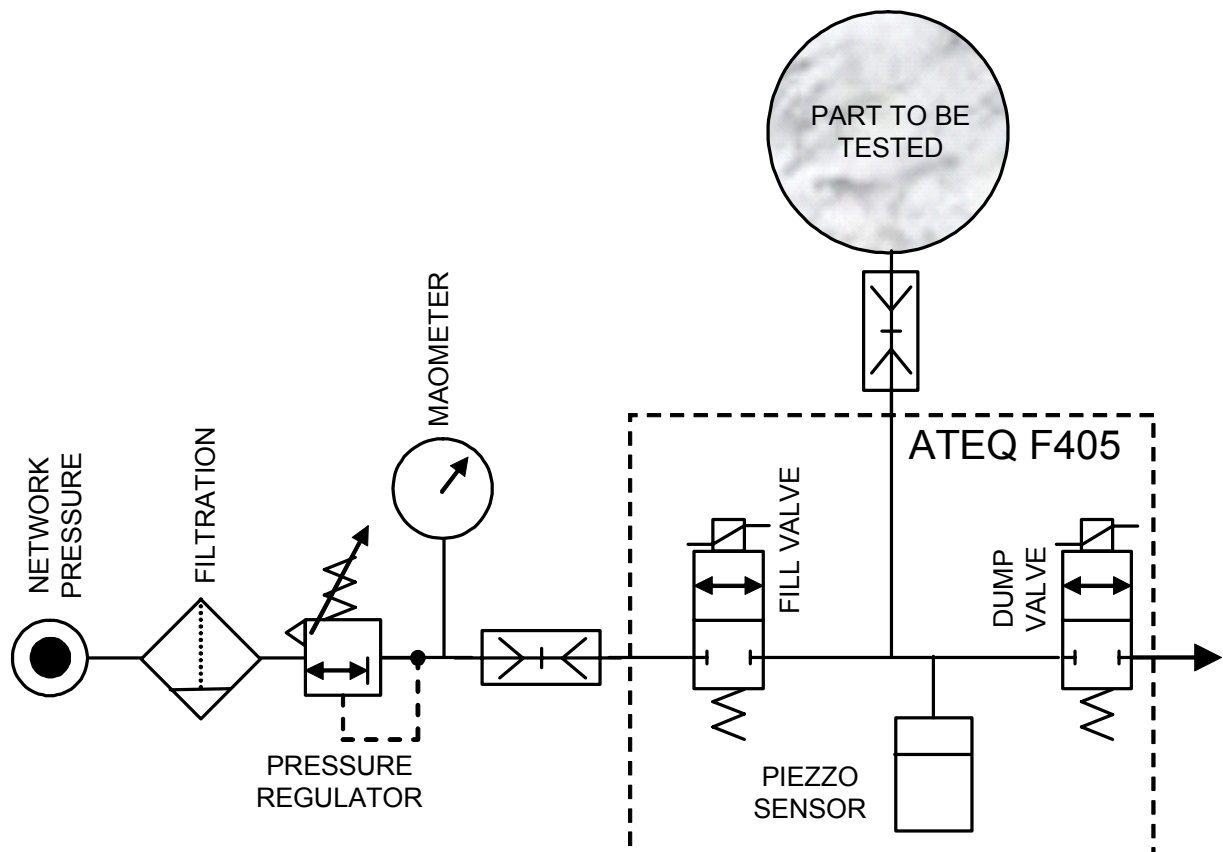

## 2. MEASUREMENT CHARACTERISTICS

### 2.1. MEASUREMENT RANGES

<b>PRESSURE RANGE</b>	<b>MESUREMENT RANGE</b>	<b>ACCURACY</b>	<b>maximum RESOLUTION</b>
<b>-80 &gt; -2 kPa</b> (-800 > -20 mbar)	1 > 500 Pa	+/- 4 % of the full scale	1 Pa
	10 > 1000 Pa		
	10 > 5000 Pa		
	10 > 10000 Pa		
<b>5 &gt; 50 kPa</b> (50 > 500 mbar)	1 > 500 Pa	+/- 4 % of the full scale	1 Pa
	10 > 1 000 Pa		
	10 > 5 000 Pa		
	10 > 10 000 Pa		
<b>20 &gt; 400 kPa</b> (0,2 > 4 bar)	10 > 1 000 Pa	+/- 4 % of the full scale	10 Pa
	10 > 5 000 Pa		
	10 > 10 000 Pa		
	10 > 50 000 Pa		
<b>50 &gt; 900 kPa</b> (0,5 > 9 bar)	10 > 5 000 Pa	+/- 4 % of the full scale	10 Pa
	10 > 10 000 Pa		
	10 > 50 000 Pa		
	100 > 100 000 Pa		

### 2.2. MECHANICAL PRESSURE REGULATION

20 kPa to 400 kPa / 50 kPa to 900 kPa.

For other specific pressures please contact ATEQ.

### 3. THE MAIN TYPES OF MEASUREMENT

There are two main measurement methods that can be performed by the **ATEQ F405**, direct measurement or indirect measurement. These two methods apply to measurements taken both under pressure and in vacuum conditions.

The configuration is determined by the application and must be carried out prior to the use of the instrument.

#### 3.1. DIRECT/PRESSURE DROP MEASUREMENT

After filling the test part to the required pressure level, the instrument measures the drop in pressure.

At the end of a cycle, the **ATEQ** empties the components via the dump valve.

#### 3.2. INDIRECT/PRESSURE RISE MEASUREMENT

The test part is placed in a sealed bell and the **ATEQ F405** is pneumatically connected to the bell. The part is externally pressurised (with up to 20 MPa or 200 bar), and the bell is lightly pressurised. In the event of a part leakage, the pressure in the bell will rise. This method allows certain parts to be tested at high pressure levels whilst avoiding the associated constraints. The **ATEQ F405** only tests and measures the pressure in the bell. In the event of a large leak, electronic monitoring of the pressure in the bell will switch the instrument to safety.

#### 4. DIRECT MEASUREMENT, PRESSURISATION

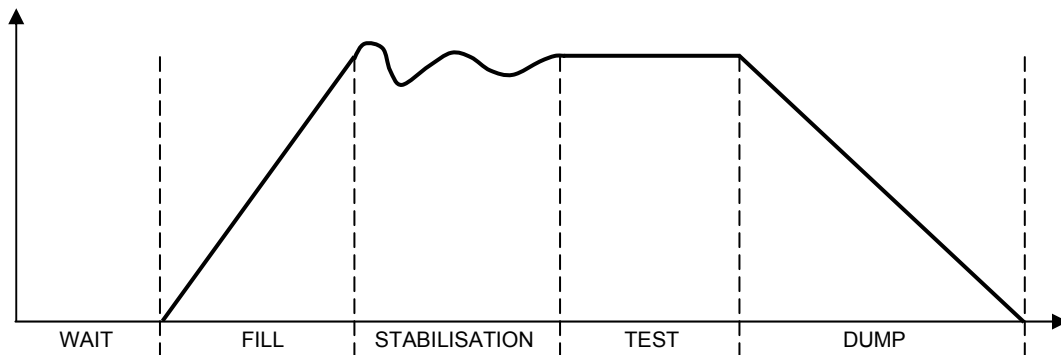





The measurement cycle consists of 5 phases:

	1	2	3	4	5	
Start	<b>Wait</b>	<b>Fill</b>	<b>Stabilization</b>	<b>Test</b>	<b>Dump</b>	Cycle end

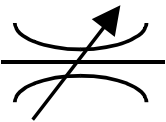
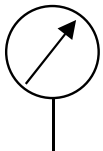
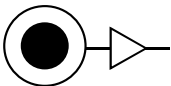
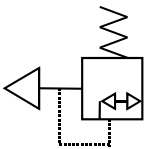
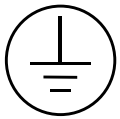
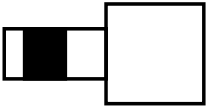
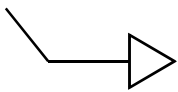
<b>Start</b>	Cycle start.
The <b>wait</b> time	The time during which the sealing connections are made to the test parts before the part is filled. The instrument may be fitted with the optional automatic connector (this option adds an extra valve). This valve is controlled for the duration of the cycle to enable the installation of the expandable joint connectors to be checked.
The <b>fill</b> time	Pressurisation of the test part. At the end of the fill time, the <b>ATEQ</b> instrument checks the test pressure. If this is not correct, the instrument will signal a test pressure error.
The <b>stabilization</b> time	The test part is completely cut off from the air supply, but remains pressurised to the test pressure level. Pressure and temperature will then stabilise in the part. If the test pressure is incorrect (a large leak), the test pressure will drop rapidly, the instrument will not move on to the test mode and will indicate an error.
The <b>test</b> time	Time during which the pressure sensor measures the changes in pressure in the test part. The signal is electronically assessed and displayed, the part is then diagnosed as good or bad.
The <b>dump</b> time	Return of the part to atmospheric conditions.
<b>Cycle end</b>	Once the dump has been carried out, the instrument emits a cycle end signal and the automatic connector valve (optional) is deactivated. This valve can control one or more expandable connectors from the beginning to the end of the cycle.

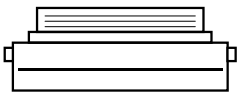
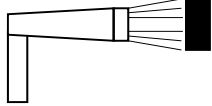
## 5. SYMBOLS PRESENTATION

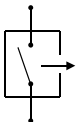
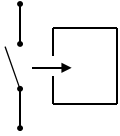
Symbol	Name	Function
	Adjustable leak connector	Pneumatic connector for the plugging of a calibrated leak (ruby kind) or an adjustable leak.
	Pressure connector	Pneumatic connector for the plugging of a manometer for an external checking of the pressure.
	Pressure supply	of the air supply from the 6 bar network.
	Test circuit supply	Pneumatic connector (according to option) for the plugging of a supplementary pneumatic supply, used in the event of the test pressure being greater than 8 bar.
	Ground connector	Connector for the electric connection to the ground.
	Automatic connector	Pneumatic connector for the driving of an external logic or pneumatic components (pneumatic sealing connector).
	Connector	Connector for a pneumatic output.
	Connector	Connector for a pneumatic input.
	Warning!	Read and respect the instructions of the user manual, before connecting and using the instrument.
	Printer	Printer connection socket.
	Bar code reader	Bar code reader connection socket.

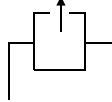
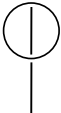
Symbol	Name	Function
	Output	Dry contact output.
	Input	Dry contact input.
	Infrared link	The receiver and transmitter of the infrared link is located here.
	Analogue output	Analogue output.
	Analogue input	Analogue input for the temperature sensor.

## Chapter 1

# INSTALLATION OF THE INSTRUMENT

### 1. APPEARANCE OF THE ATEQ F405

The **ATEQ F405** is supplied in a ABS blind case containing a pneumatic module (valves) and a small remote control ABS case gathering the front face functions (keyboard and display) allowing the pneumatic module driving.

The connection between the remote control and the pneumatic case is made by a link wire with two M12 connectors (Lumberg type) supplied with the instrument.

A 24 V DC power supply unit is supplied with the instrument.

#### 1.1. PNEUMATIC CASE

##### 1.1.1. Upper side

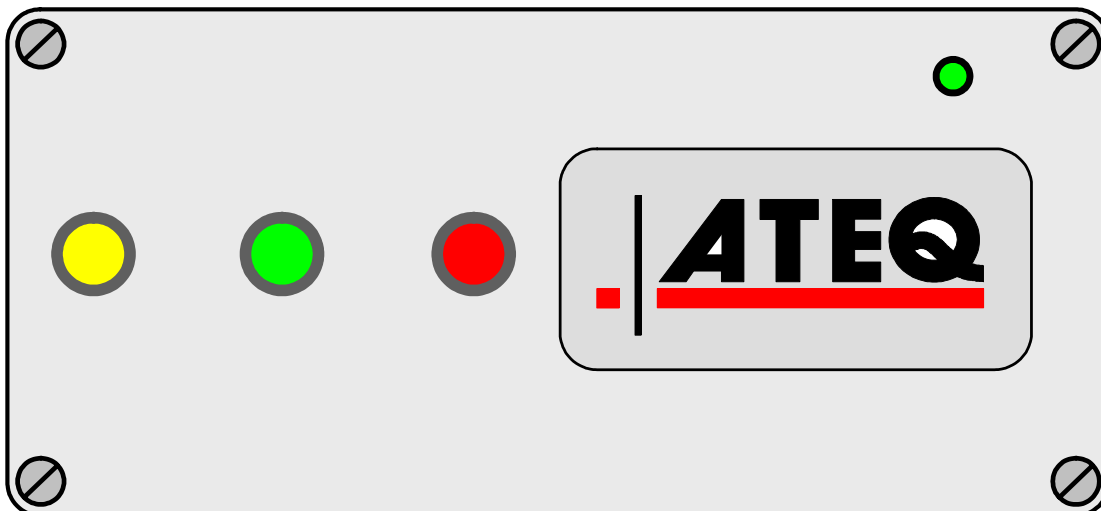

#### 1.2. REMOTE CONTROL

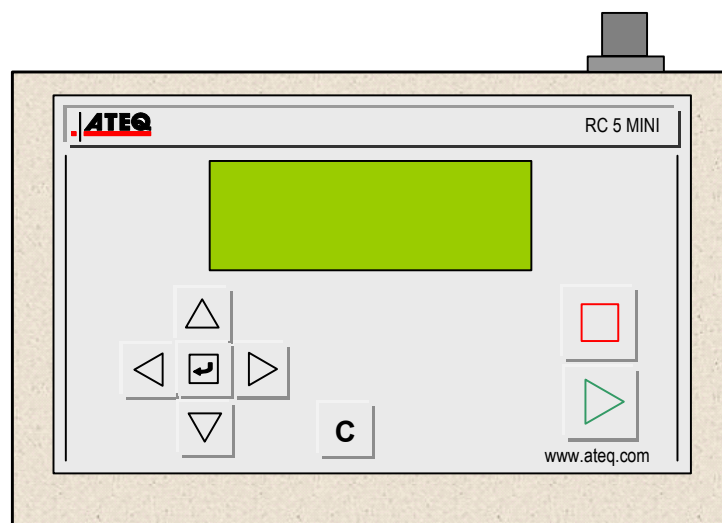

## 2. INSTALLATION OF THE INSTRUMENT

### 2.1. LAYOUT OF THE CONNECTOR ON THE REMOTE CONTROL

#### 2.1.1. 1) Remote control connector

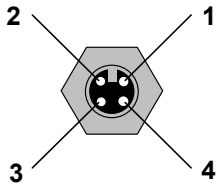

Used for the connection of the remote control to the pneumatic case.  
(Lumberg male connector).

PIN 1	Network
PIN 2	+ 24V Power supply
PIN 3	Network
PIN 4	0V Earth

### 2.2. LAYOUT OF CONNECTORS ON THE F405 CASE

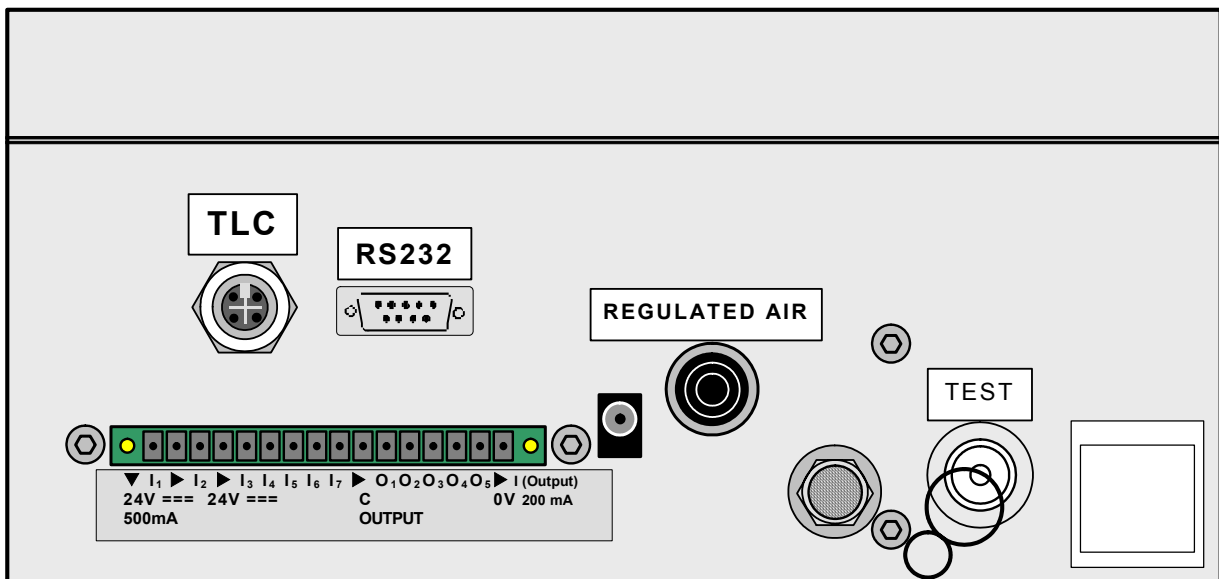

### 2.3. ELECTRICAL CONNECTORS DETAILS

#### 2.3.1. Remote control connector

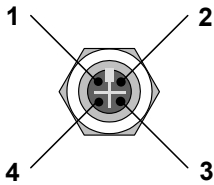

Used for connection of the remote control.  
(Lumberg female connector).

PIN 1	Network
PIN 2	+ 24V Power supply
PIN 3	Network
PIN 4	0V Earth

#### 2.3.2. J3 Connector (I/O Inputs/Outputs)

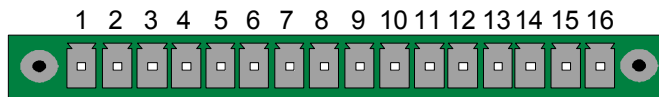

PIN 1	Reset (IN 1)	DRY CONTACT INPUT  (Activation by 24 V DC)
PIN 2	Common (+ 24 V)	
PIN 3	START (IN 2)	
PIN 4	Common (+ 24 V)	
PIN 5	Input program selection (IN 3)	
PIN 6	Input program selection (IN 4)	
PIN 7	Programmable input (IN 5)	
PIN 8	Not used	
PIN 9	Not used	DRY CONTACT OUTPUT  60V AC / DC Max 200mA Max
PIN 10	Common	
PIN 11	Part OK output	
PIN 12	Test part default output	
PIN 13	Not used	
PIN 14	Warning output	
PIN 15	Cycle end output	
PIN 16	0 V	

**2.3.2. 1) Activating a program from the J3 connector inputs**

To activate a program from the J3 connector inputs, you have to select pins 5 to 9 (one or more). Binary weight  $n + 1$ .

**Pin combinations for program selection**

Program number	Pin 5 (Input 3)	Pin 6 (Input 4)	Pin 7 (Input 5)
1	0	0	0
2	1	0	0
3	0	1	0
4	1	1	0
5	0	0	1
6	1	0	1
7	0	1	1
8	1	1	1

**2.3.2. 2) J3 Connector (Binary inputs/outputs) programmable input**

Input 7 (pin 9) parameters can be set in the **CONFIGURATION/CHANGE I/O** menu.

The functions which can be programmed and are available on this input are all the specials cycle:

- ✓ Program selection.
- ✓ Regulator adjust request.
- ✓ Infinite fill request.
- ✓ Piezo auto zero request.
- ✓ Auto test request.

Some possibilities appear only if the function is used.

2.3.2. 3) J3 Connector (binary inputs/outputs) diagram

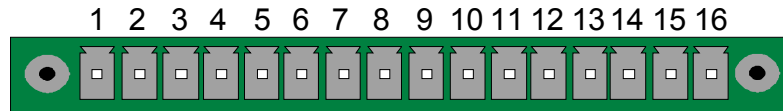

a) PLC in NPN mode connection

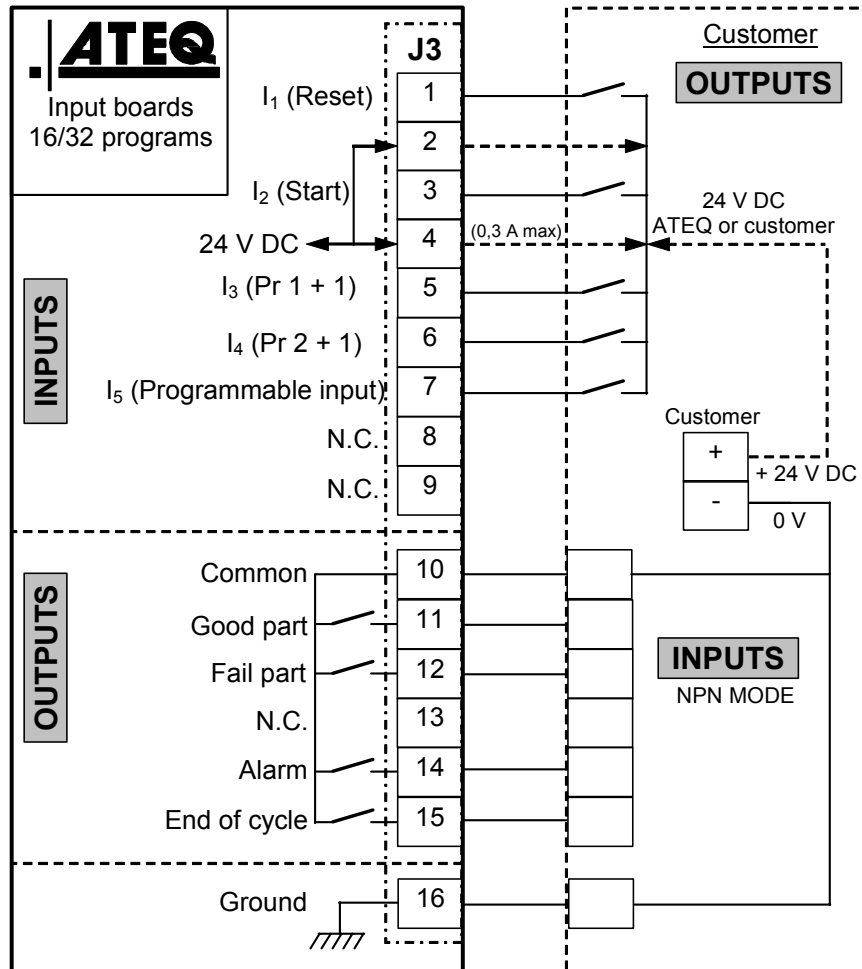

**Note:** The 24V power supply must be provided by the internal power supply of the ATEQ instrument (0,3A maximum) **OR** through an external power supply provided by the customer.

In the case of customer external supply, the ATEQ instrument can be supply by the 2 and 4 pins on the J3 connector too.

**b) PLC in PNP mode connection**

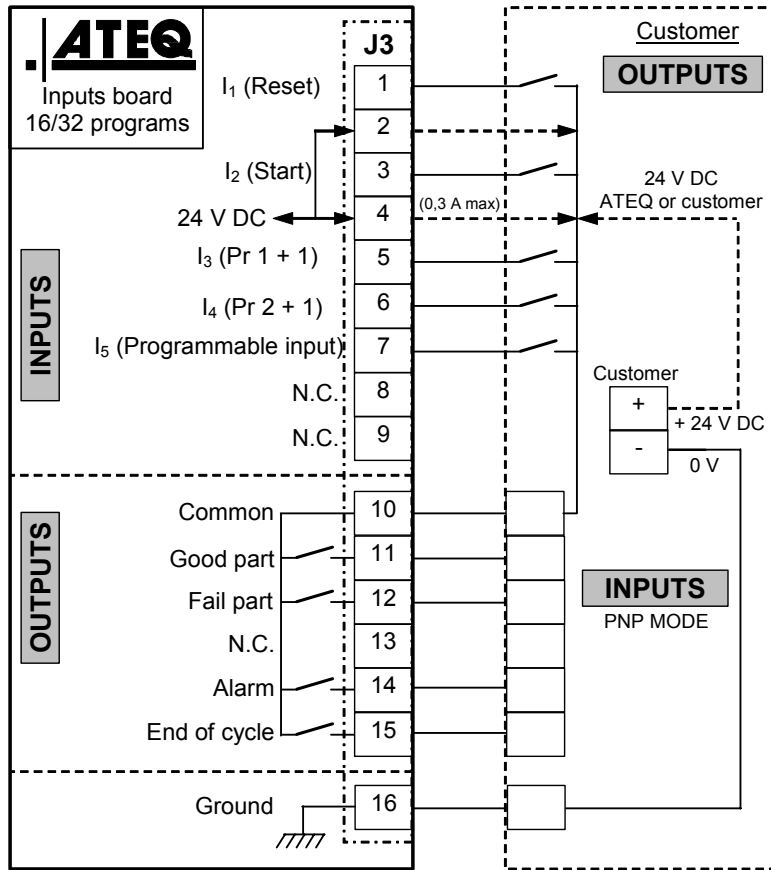

**Note:** The 24V power supply must be provided by the internal power supply of the ATEQ instrument (0,3A maximum) **OR** through an external power supply provided by the customer.

In the case of customer external supply, the ATEQ instrument can be supply by the 2 and 4 pins on the J3 connector too.

**c) Lights connection**

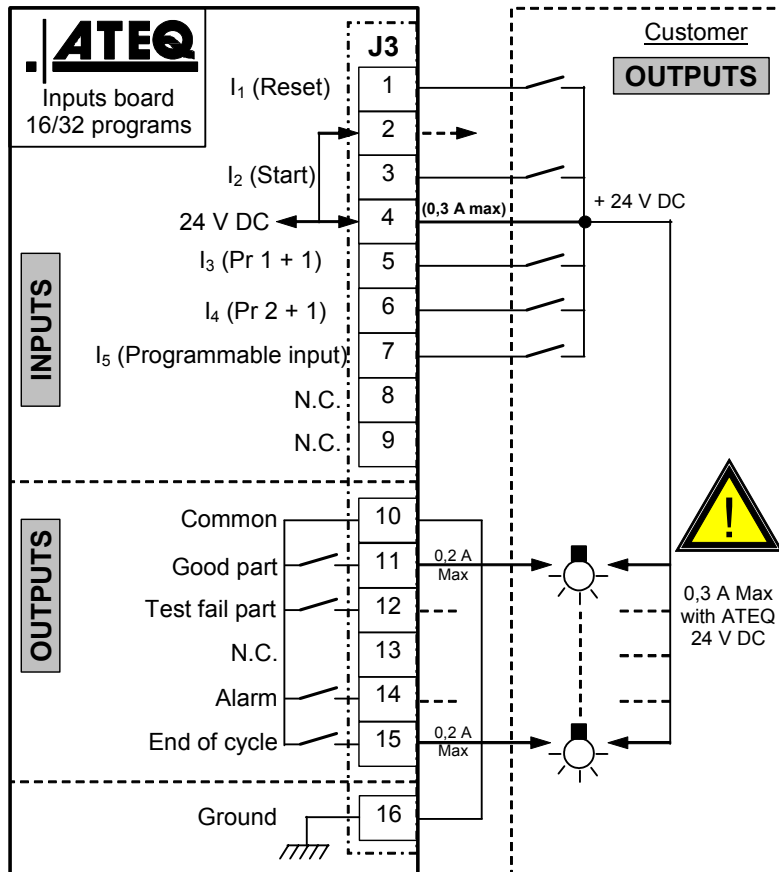

**Note:** The 24V power supply must be provided by the internal power supply of the ATEQ instrument (0,3A maximum) **OR** through an external power supply provided by the customer.

In the case of customer external supply, the ATEQ instrument can be supply by the 2 and 4 pins on the J3 connector too.

**2.3.2. 4) 24 V DC power supply connector**

The **ATEQ F405** operates on a voltage of 24V DC using the external power supply.

Used for connection of the power supply.



The voltage must be 24 V DC with minimum current 1.25 A.

The instrument can be supplied from the J3 connector relay board on the 24 V DC pin.

**2.3.2. 5) J8 Connector (RS232)**

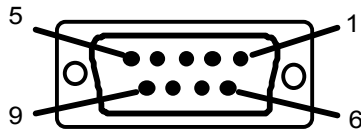

Used for the connection of a printer, a bar-code reader, a PC or a memory module.

PIN 1	Not used	PIN 6	+ 5 V DC 200 mA Max
PIN 2	RXD Data reception	PIN 7	RTS request to send
PIN 3	TXD Data emission	PIN 8	CTS clear to send
PIN 4	Not used	PIN 9	Not used
PIN 5	Earth		

**2.4. PNEUMATICS CONNECTORS DETAIL**

**2.4.1. Pneumatics outputs**

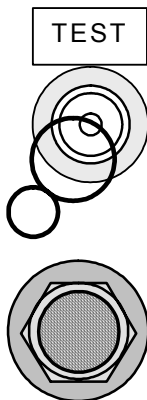

This output allows the connection to the part to be tested.

Exhaust output (dump).

**2.4.2. Pneumatic input**



Pneumatic supply of the test pressure.

### 2.4.2. 1) Pneumatic supply

It is essential that the air supplied is clean and dry. Even though there is a filter, supplied with the instrument, the presence of dust, oil or impurities may cause a malfunction.

When the instrument is working in vacuum conditions, impurities must be prevented from being drawn into it. For this purpose we strongly recommend that a suitable airtight filter is installed between the test part and the instrument. This filter can be supplied by **ATEQ**.

**The presence of impurities, oil or humidity in the air may cause deterioration which will not be covered by the guarantee.**

**In accordance with ISO standard 8573-1 concerning classes of compressed air for measurement instruments in an industrial environment:**

**ATEQ recommends:**

- |                                |         |                                     |
|--------------------------------|---------|-------------------------------------|
| • Grain size and concentration | CLASS 1 | (0.1 µm and 0.1 mg/m <sup>3</sup> ) |
| • Dew point under pressure     | CLASS 2 | (- 40° dew)                         |
| • Maximum concentration of oil | CLASS 1 | (0.01 mg/m <sup>3</sup> )           |

**ATEQ recommends the installation:**

- of an air dryer to provide dry air at less than - 40° dew point,
- of a 25 micron and 1/100 micron double filter.

## Chapter 2

---

# USER INTERFACES

---

### 1. ATEQ F405 APPEARANCE

#### 1.1. PNEUMATIC CASE

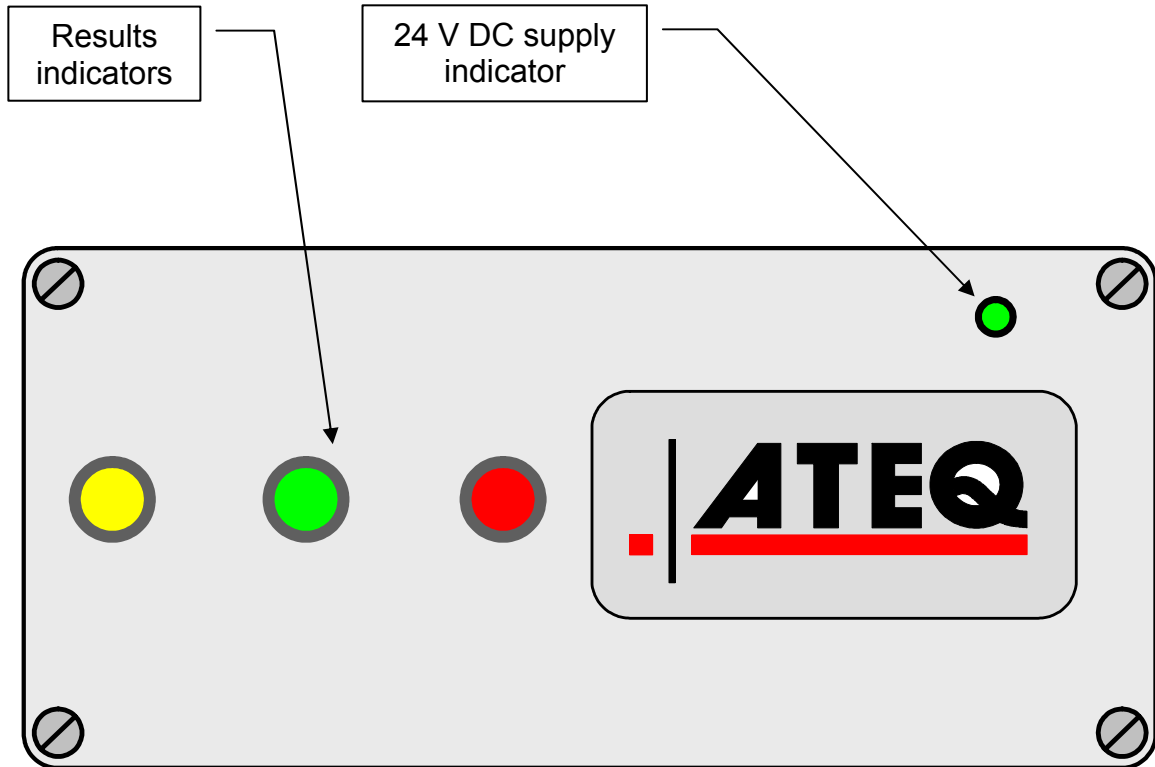

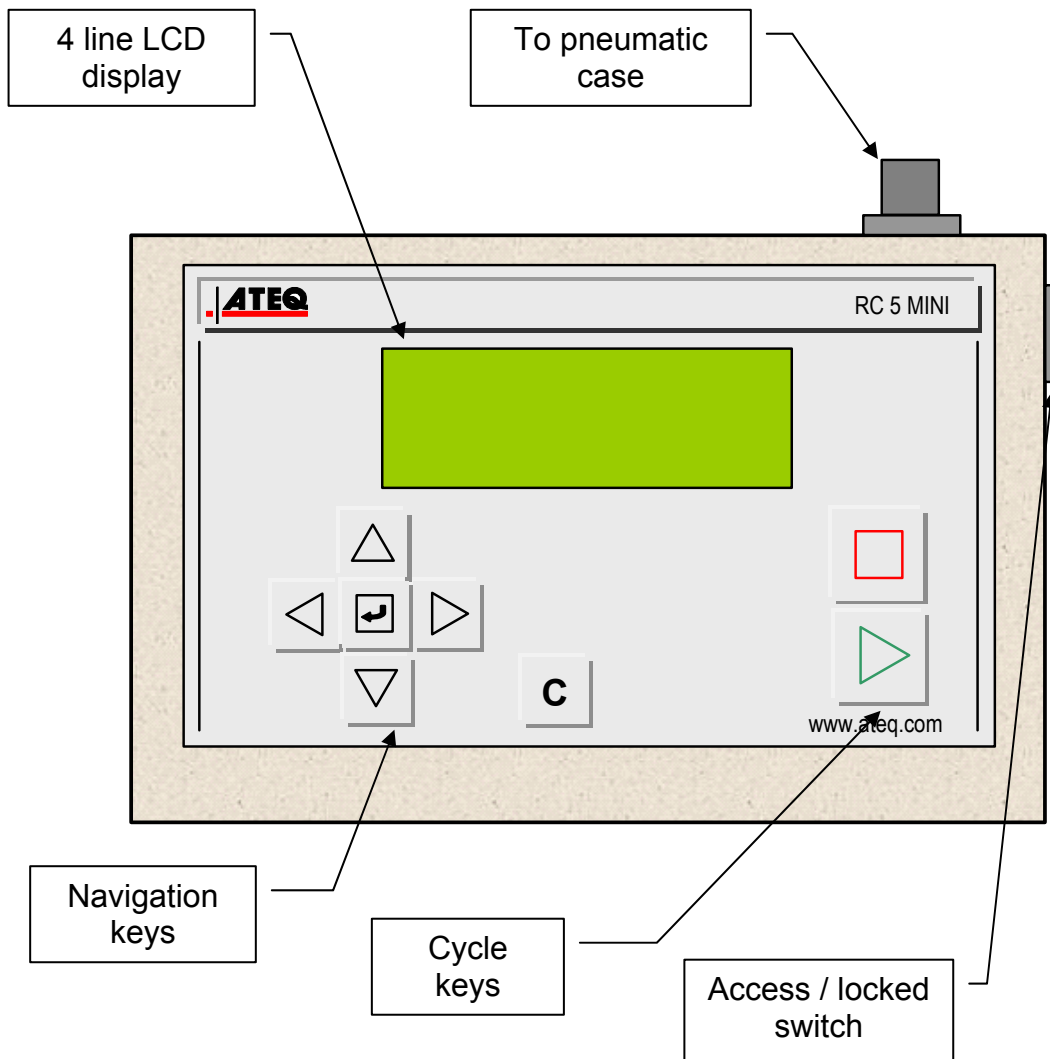

1.2. REMOTE CONTROL



## 2. PNEUMATIC CASE

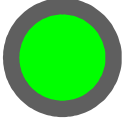
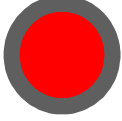





### 2.1. FUNCTIONS OF THE INDICATOR LIGHTS

24 V DC power supply indicator.	 Small green L.E.D.
Good part light.	 Big green L.E.D.
<p>Fail part indicator indicating a leak in excess of the reject threshold for pressure measurements or an increase in volume during vacuum condition measurements.</p> <p>Fail part indicator indicating a “negative” leak in excess in absolute terms of the reject threshold for vacuum measurements or an increase in pressure during pressure condition measurements.</p>	 Big red L.E.D.
Cycle in progress light.	 Big yellow L.E.D.

### 3. REMOTE CONTROL

#### 3.1. APPEARANCE OF THE KEYBOARD

##### 3.1.1. Navigation keys

KEY	FUNCTION
	Scroll up or increase numerical values
	Scroll down or decrease numerical values
	Not used
	Not used
	<b>ENTER</b> key Opening a menu Entering a parameter Confirmation of a parameter
	« <b>C</b> » for <b>CANCEL</b> Return to the previous menu or function Escape without modifying a parameter

##### 3.1.2. Cycle keys

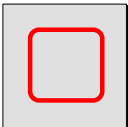
KEY	FUNCTION
	<b>START</b> key Starts a measurement cycle
	<b>RESET</b> key Stops a cycle in progress

## 3.2. LOCKABLE SWITCH

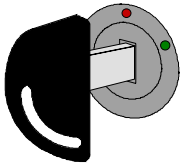
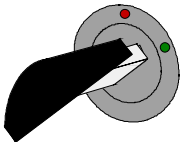
POSITION	FUNCTION
	<p><b>LOCKED</b> position. Access to adjustable parameters not possible.</p>
	<p><b>ACCESS</b> position. Adjustable parameters may be accessed.</p>

**NB:** whatever position the key is in (**LOCKED** or **ACCESS**), test cycles can be started and stopped.

## 3.3. 4 LINE LCD DISPLAY

```

ATEQ F405
Version XX.XXi
0->10000 mbar
0.01->5.00 kPa

```

Used to display measurements and adjustable parameters. In the opposite example, XX.XXi represents the program version for the instrument.



## Chapter 3

## START-UP AND SETTINGS



## 1. POWERING-UP THE ATEQ F405

Supply the instrument with 24 V DC. When switched on, the instrument:		
- Displays the version and the full scale of the sensors...		<pre>ATEQ F405 Version XX.XXi 0-&gt;10000 mbar 0.01-&gt;5.00 kPa</pre>
...then displays the main menu.		<pre>CYCLE/Pr : 001 PRESS = 0.000 bar  READY</pre>

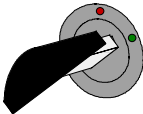
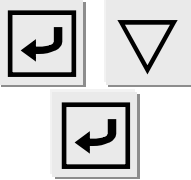
## 2. CREATION OF A TEST PROGRAM

To modify the parameters, turn the key to the <b>ACCESS</b> position.		<pre>RUN/Pr: 001 PRESS = 0.000 bar  READY</pre>
To access the main menu, press <b>ENTER</b> . In the main menu, place the cursor in front of the <b>PARAMETERS</b> menu. Confirm with the <b>ENTER</b> key.		<pre>MAIN MENU RUN PROG. : --- PARAMETERS SPE CYCLE : Disabled</pre>
The <b>PARAMETERS</b> menu is used to manage test programs.  ☞ If the various programs to be created have different parameters, they must be created one by one.  ☞ If the programs have identical parameters, a base program can be created and then the <b>Copy-Paste</b> function can be used to duplicate the program as many times as necessary.		<pre>PARAMETERS Copy-Paste Pr : 001 ----- Pr : 002 -----</pre>

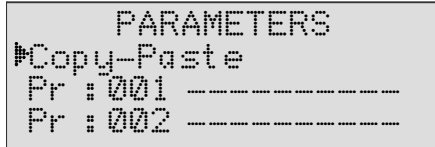

### 2.1. CHOICE OF THE PROGRAM NUMBER

<p>Position the cursor in front of the chosen program number and confirm with the <b>ENTER</b> key.</p>	 	
---	---	--

**Note:** the instrument has four programs maximum.

### 2.2. TEST TYPE SELECTION

Four test types are available.

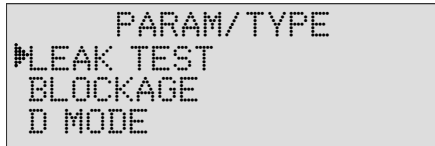
<p>The <b>PARAMETERS</b> menu gives access to four possible types of test: leak test (<b>LEAK TEST</b>), pressure test (<b>BLOCKAGE</b>), desensitised mode test (<b>D. MODE</b>) and an operator test (<b>OPERATOR</b>); see the following paragraph for explanations. Put the cursor in front of the required test type and confirm with the <b>ENTER</b> key.</p>	 	
--	---	--

#### 2.2.1. Leak test

The leak test is most suitable for measuring small leaks (pressure drop). The following formula is used to convert a leak expressed in units of flow to a drop in pressure

$$\Delta P \text{ (Pa/s)} = \frac{F \text{ (cm}^3\text{/min)}}{0,0006 \times V \text{ (cm}^3\text{)}}$$

F(cm<sup>3</sup>/min) = Leak flow                      V (cm<sup>3</sup>) = volume of the test part  
 0.0006 = constant                              ΔP (Pa/s) = pressure drop

**Example:**

Part which has dP/dt = 50 Pa/s			Part which has dP/dt = 1 Pa/s		
Test	Pa/s	Pa	Test	Pa/s	Pa
1 s	50	50	1 s	1	1
2 s	50	100	2 s	1	2
3 s	50	150	3 s	1	3
.	.	.	.	.	.
.	.	.	.	.	.
n s	50	nx50	n s	1	n

The choice of working in Pa or in Pa/s depends on the application. In all events, it must not be forgotten that the full scale of the sensor in Pa or Pa/s is limited to 50 or 500 Pa depending on the instrument configuration.

### 2.2.2. Blockage test mode

The blockage mode is used for rough measurement of a flow, based on the measurement of back pressure. The standard pressure limits are used to classify the results as good or bad. The cycle only contains the fill phase and the measurement is carried out during this phase.

If the pressure measured is below the minimum limit, then the flow is too large.

If the pressure measured is in excess of the maximum limit, then the flow is too small.

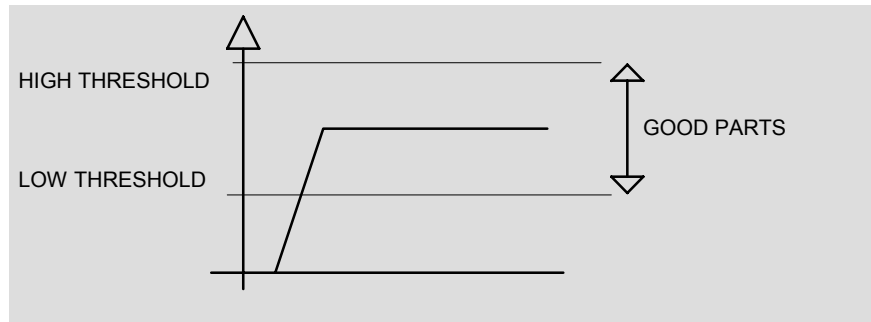

### 2.2.3. Desensitized mode test

This mode is used for the measurement of large leaks, when the reject level required is above 500 Pa.

The unit used during the reading of the pressure drop in desensitized mode is the unit which is used for the display of the test pressure (identical resolution). The limits will also be indicated in this unit.

☞ The Custom unit check function cannot be used in this mode.

### 2.2.4. Operator mode test







This type of test means that the operator can carry out operations on the part whilst under test, then confirm these operations using a "START"  key if the operator

test is good, or the "RESET"  key if the test is failed.

### 2.3. PARAMETER SETTINGS

Once the test type is chosen, the test cycle parameters must be set.

The procedure to follow for setting the test parameters is identical in each case. Example: Coupling time A.

<p>First, position the cursor in front of the chosen parameter using the navigation keys (here, Coupl. A).</p>		<pre>PARAM/pr001 TYPE : LEAK TEST COUPL. A: 00.00 s FILL    : 00.00 s</pre>
<p>Then, confirm with the <b>ENTER</b> key. The cursor will move to the right of the display.</p>		<pre>PARAM/pr001 TYPE : LEAK TEST COUPL. A: 00.00 s FILL    : 00.00 s</pre>
<p>Modify the value using the navigation keys.</p>		<pre>PARAM/pr001 TYPE : LEAK TEST COUPL. A: 00.03 s FILL    : 00.00 s</pre>
<p>Once the value is modified, confirm with the <b>ENTER</b> key.</p>		<pre>PARAM/pr001 TYPE : LEAK TEST COUPL. A: 03.00 s FILL    : 00.00 s</pre>
<p>To move on to the next parameter, use the navigation keys.</p>		<pre>PARAM/pr001 TYPE : LEAK TEST COUPL. A: 03.00 s FILL    : 00.00 s</pre>
<p>To exit from the menu, use the <b>CANCEL</b> key.</p>		<pre>PARAMETERS Cut-Paste Pr: 001 LEAK Pr: 002 LEAK</pre>

#### 2.3.1. Coupling time

Coupling times A and B are start of cycle parameters.

If there is no automatic connector, Coupling time A is part of the cycle.

If an instrument is fitted with an automatic connector, Coupling time A delays the pressurisation of the test part by allowing the activation of a first cycle connector at the test start. Coupling time B allows the activation of a second automatic connector. These Coupling times ensure better stabilization of the seals placed on the test part.

☞ Set this parameter using the method described in § 2.3.

### 2.3.2. Fill time

This is the time allowed for the pressurisation of the part to be tested. It must not be too long (waste of time) or too short (the pressure in the component is at risk of not being sufficient due to drops in pressure caused by temperature changes).

To determine the appropriate fill time, it is necessary to set the **Fill Time** in order to make it **Too Long** (TTLR), then to shorten it until a drop in pressure occurs due to thermal effects.

Determine the TTLR by using the following formula:

$$\text{TTLR} = \sqrt[4]{\text{volume in cm}^3 \times \text{test pressure in mbar}}$$

- ✓ Carry out a cycle. When the instrument switches to the stabilization period, the pressure must remain stable.
- ✓ A pressure drop (since there will be no fall in pressure due to thermal effects) signifies the presence of a large leak; check the test part and the pneumatic assembly components, then start again.
- ✓ If the pressure remains stable, the part does not contain a large leak and the fill time is too long. Shorten it progressively by carrying out cycles until a drop in pressure is noticeable.
- ✓ As soon as a fall in pressure due to thermal effects appears, the fill time has become too short. Increase it slightly.

☞ Set this parameter using the method described in § 2.3.

### 2.3.3. Stabilization time

This time is used to stabilise the pressure in the test circuit.

It is possible that a change in pressure occurs due to thermal exchanges between the components. If the instrument takes a measurement too early, the instrument will indicate the presence of a large leak.

- ✓ To determine the correct stabilization time, it is necessary to set a long time so that the reading at the end of the test time is equal to zero.
- ✓ Set the stabilization time to four times the length of the fill time.
- ✓ Carry out a cycle. When the instrument switches to the test period, the pressure must remain at zero.
- ✓ If there is a drop in pressure, there is a small leak present. Check the test part and the pneumatic connections, then start again.
- ✓ If the pressure is stable, the part does not contain a small leak and the stabilization time is therefore too long. Progressively shorten and carry out cycles (wait one minute between each cycle) until you see the appearance of a drop in pressure. This indicates that the stabilization time has become too short. Increase it slightly.

☞ Set this parameter using the method described in § 2.3.

### 2.3.4. Test time

The test time depends on the programmed reject level and operation mode.

In the dP/dt (Pa/s) mode, the variation in measured pressure is due to the drift in the pressure drop.

In the dP (Pa) mode, the pressure variation measured is the total of the pressure drop over the whole test time. This mode is more unstable, but is more sensitive. The instrument totals all the variations occurring due to variations in volume or temperature over the whole of the test time.

☞ Set this parameter using the method described in § 2.3.

### 2.3.5. Dump time

The instrument will as default propose a dump time of zero. This must be set by carrying out several tests.

☞ Set this parameter using the method described in § 2.3.

### 2.3.6. Pressure units

The different units are bar, mbar, PSI, Pa, kPa, MPa. .

☞ Set this parameter using the method described in § 2.3.

### 2.3.7. Maximum fill

This function is used to set a maximum limit for the fill pressure. A warning is triggered if this limit is exceeded.



When test time is infinite, the maximum fill pressure monitoring is inoperative. Care should therefore be taken to avoid excess pressure being applied to the part during the test.

☞ Set this parameter using the method described in § 2.3.

### 2.3.8. Minimum fill

This function is used to set a minimum limit for the fill pressure. A warning is triggered if this limit is not reached.

☞ Set this parameter using the method described in § 2.3.

### 2.3.9. Reject unit

Pa, Pa/s, Cal-Pa, Cal-Pa/s, cm<sup>3</sup>/min, cm<sup>3</sup>/s, cm<sup>3</sup>/h, mm<sup>3</sup>/s.

If a unit of flow is selected, two parameters will be added to the program:

- ✓ the choice of the flow calculation basis, in Pa or Pa/s
- ✓ the volume of the test part (+pipes).

There is a special "Cal learn" cycle to determine a basic unit of flow. (see chapter 4 § 3.5 "manual calibration").

**Note:** high resolution enables an extra figure to be displayed (i.e. 1/10<sup>th</sup> Pa)

☞ Set this parameter using the method described in § 2.3.

### 2.3.10. Test reject

This function is used to set a limit level below which the part is considered to be bad.

☞ Set this parameter using the method described in § 2.3.









### 2.3.11. Functions

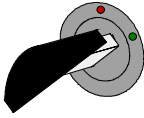

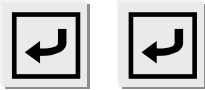

The **FUNCTION** menu gives access to additional parameters which must first be activated in the **CONFIGURATION** menu and then the **EXTENDED MENU**.

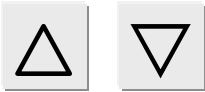
If no additional parameters are confirmed in the **EXTENDED MENUS**, the **FUNCTION** menu will be empty when selected.





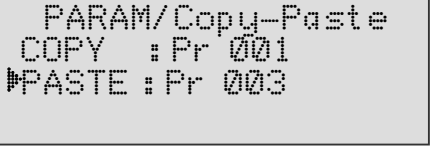

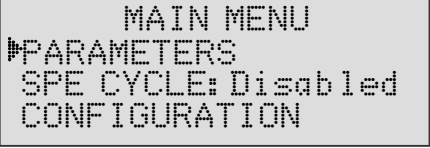

To activate these parameters refer to chapter 4 § 2.

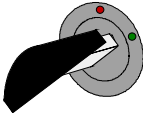
### 3. DUPLICATION OF A TEST PROGRAM

<p>To modify the parameters, turn the key to the <b>ACCESS</b> position.</p>		
<p>Starting from the main menu, position the cursor in front of the <b>PARAMETERS</b> function.</p>		<pre> MAIN MENU RUN PROG.: 001 PARAMETERS SPE CYCLE : Disabled                     </pre>
<p>Confirm with the <b>ENTER</b> key. The cursor will appear in front of the Copy-Paste function. Confirm the function again using the <b>ENTER</b> key.</p>		<pre> PARAMETERS Copy-Paste Pr : 001 ENGINE Pr : 002 HEAD                     </pre>
<p>Next, confirm the <b>COPY</b> function.</p>		<pre> PARAM/ Copy-Paste COPY      : Pr --- PASTE     : Pr ---                     </pre>
<p>Display the number of the program to be copied using the navigation keys. (In this case, program no.1).</p>		<pre> PARAM/ Copy-Paste COPY      : Pr 001 4 PASTE     : Pr ---                     </pre>
<p>Confirm using the <b>ENTER</b> key.</p>		<pre> PARAM/ Copy-Paste COPY      : Pr 001 PASTE     : Pr ---                     </pre>
<p>Place the cursor in front of <b>PASTE</b>.</p>		<pre> PARAM/ Copy-Paste COPY      : Pr 001 PASTE     : Pr ---                     </pre>
<p>Confirm with the <b>ENTER</b> key. Assign a number to this new program using the navigation keys (For example no.3).</p>		<pre> PARAM/ Copy-Paste COPY      : Pr 001 PASTE     : Pr 003 4                     </pre>

<p>Confirm with the <b>ENTER</b> key, The display confirms that the program has been copied.</p>		
<p>The program no.1 parameters have now been copied into program no.3 parameters. In this example program no.3 is an exact copy of program n°1.</p>		
<p>Press the <b>CANCEL</b> key twice to return to the main menu.</p>		





#### 4. DELETING A PROGRAM OR A PROGRAM NAME

<p>To modify the parameters, turn the key to the <b>ACCESS</b> position.</p>		
<p>Position the cursor in front of the <b>PARAMETERS</b> function. Confirm with the <b>ENTER</b> key.</p>		<pre> MAIN MENU RUN PROG.: 001 PARAMETERS SPE CYCLE : Disabled                     </pre>
<p>Position the cursor in front of the program number or the program name to be deleted.</p>		<pre> PARAMETERS Copy-Paste Pr: 001 ENGINE Pr: 002 HEAD                     </pre>
<p>Confirm once to enter the program.</p>		<pre> PARAM/Pr001 TYPE : LEAK WAIT A: 00.00 s WAIT B: 00.00 s                     </pre>
<p>Confirm a second time to gain access to the delete menu. There are two possibilities: delete the program name or delete the whole program.</p>		<pre> M/Pr001/TEST TYPE Delete name Program reset                     </pre>
<p>1°) Confirm a third time. The name of the program is deleted.</p>		<pre> PARAMETERS Copy-Paste Pr: 001 ----- Pr: 002 HEAD                     </pre>
<p>2°) Place the cursor in front of Program reset.</p>		<pre> M/Pr001/TEST TYPE Delete name Program reset                     </pre>
<p>Confirm with the <b>ENTER</b> key. The program is then deleted.</p>		<pre> PARAMETERS Copy-Paste Pr: 001 ----- Pr: 002 HEAD                     </pre>

**NB:** if the “**Program delete**” operation is carried out first, then the program name is also deleted.

## 5. STARTING A CYCLE

### 5.1. CHOICE OF THE PROGRAM TO BE RUN

<p>Position the key in the <b>ACCESS</b> position.</p>		
<p>Starting from the main menu, place the cursor in front of the <b>RUN PROG.</b> function.</p>		<pre> MAIN MENU ▶RUN PROG.: 001 PARAMETERS SPE CYCLE : Disabled                     </pre>
<p>Confirm with the <b>ENTER</b> key.</p>		<pre> MAIN MENU ▶RUN PROG.: 001 PARAMETERS SPE CYCLE : Disabled                     </pre>
<p>Display the number of the program required by scrolling through the numbers with the navigation keys.</p>		<pre> MAIN MENU RUN PROG. : 004 ◀ PARAMETERS SPE CYCLE : Disabled                     </pre>
<p>Confirm your choice with the <b>ENTER</b> key.</p>		<pre> MAIN MENU ▶RUN PROG. : 004 PARAMETERS SPE CYCLE : Disabled                     </pre>

## 6. STARTING A MEASUREMENT CYCLE





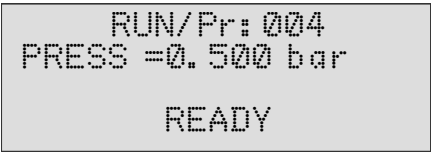

<p>Press the <b>START</b> key to start a measurement cycle.</p>		<pre> RUN/Pr: 004 PRESS =0.500 bar  READY                     </pre>
<p>The cycle phases are displayed on the LCD window:</p> <p><b>WAIT, FILL, STAB, TEST, DUMP.</b></p>		<pre> RUN/Pr: 004 PRESS =1.00 bar  STABILIZATION                     </pre>

## 7. STOPPING A CYCLE

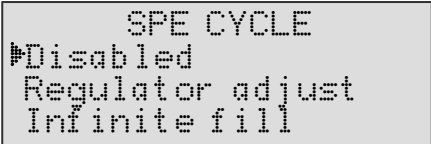
<p>Press the <b>RESET</b> key to stop the measurement. The display “<b>READY</b>” indicates that the instrument is ready to perform a new measurement test.</p>		
---	---	--

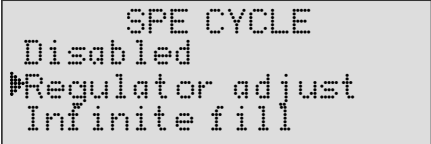
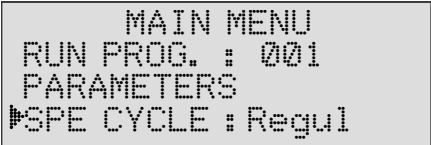
## 8. SETTING THE TEST PRESSURE

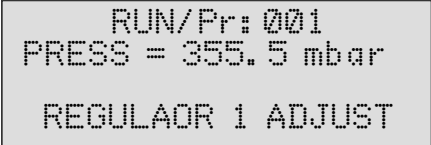
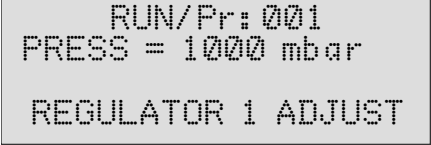
### 8.1. MANUAL SETTING WITH A MECHANICAL REGULATOR

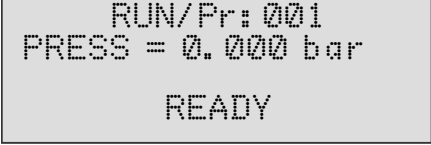
<p>Position the cursor in front of the <b>SPE CYCLE</b> function and confirm with the <b>ENTER</b> key.</p>		
<p>Next, position the cursor in front of <b>Regulator adjust</b> and confirm with the <b>ENTER</b> key.</p>		
<p>The display confirms that the special cycle has been selected.</p>		
<p>Press the <b>START</b> key to launch a special cycle.</p>		
<p>Set the test pressure.</p>		
<p>Once the pressure is set, press the <b>RESET</b> key to stop the special cycle.</p>		

## Chapter 4

# FUNCTIONS OF THE INSTRUMENT

### 1. MENU STRUCTURE

#### 1.1. MAIN MENU

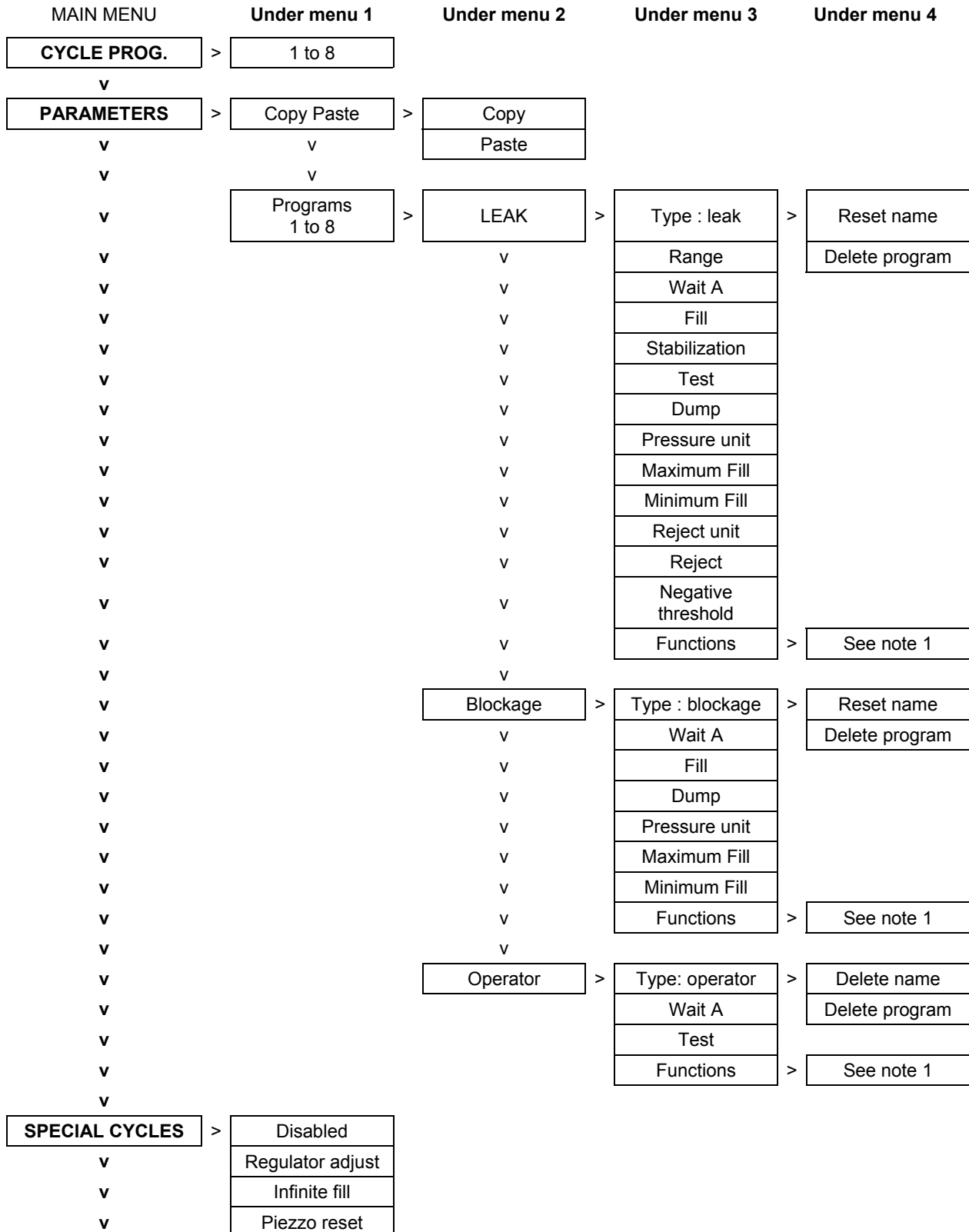



## Chapter 4 – Functions of the instrument

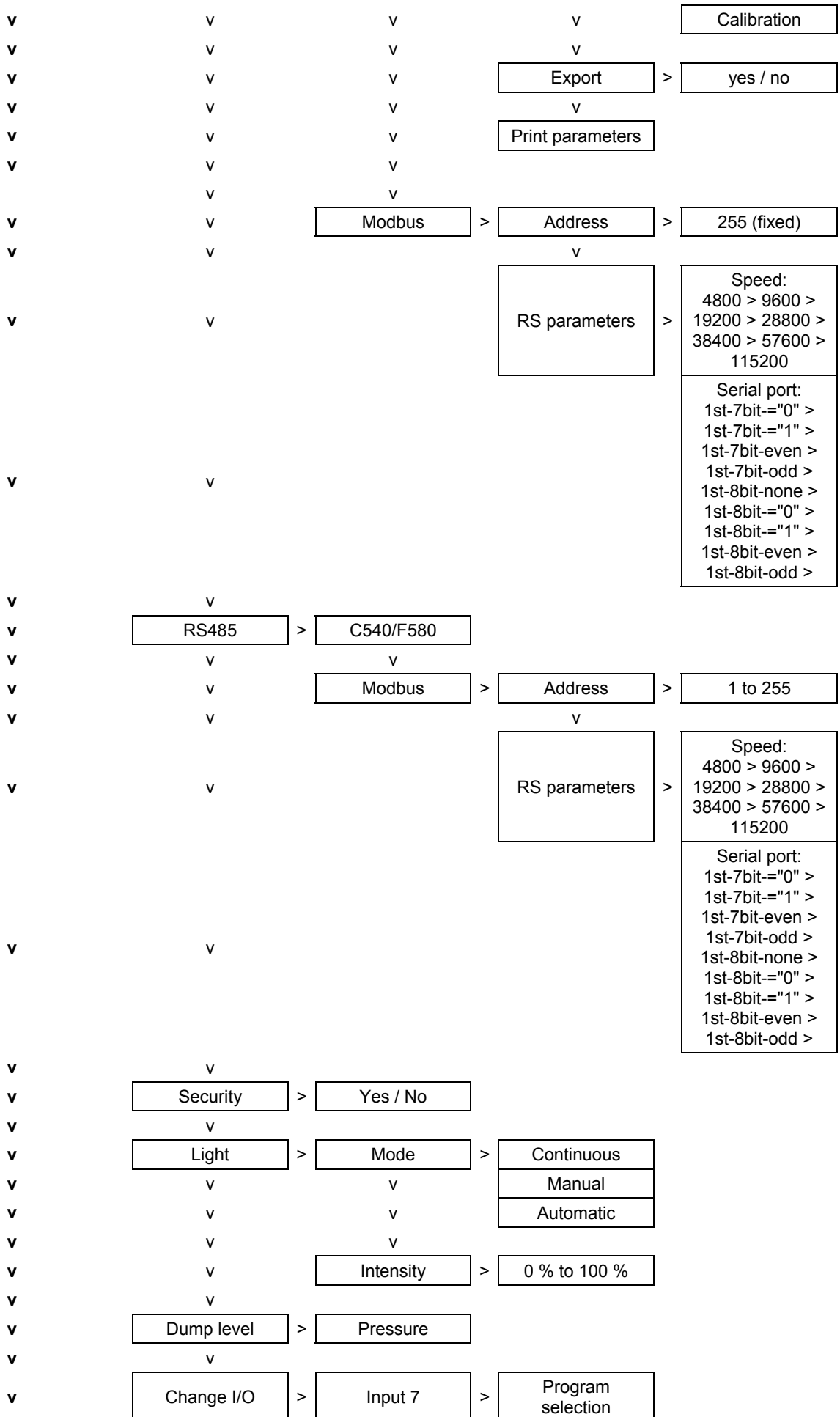

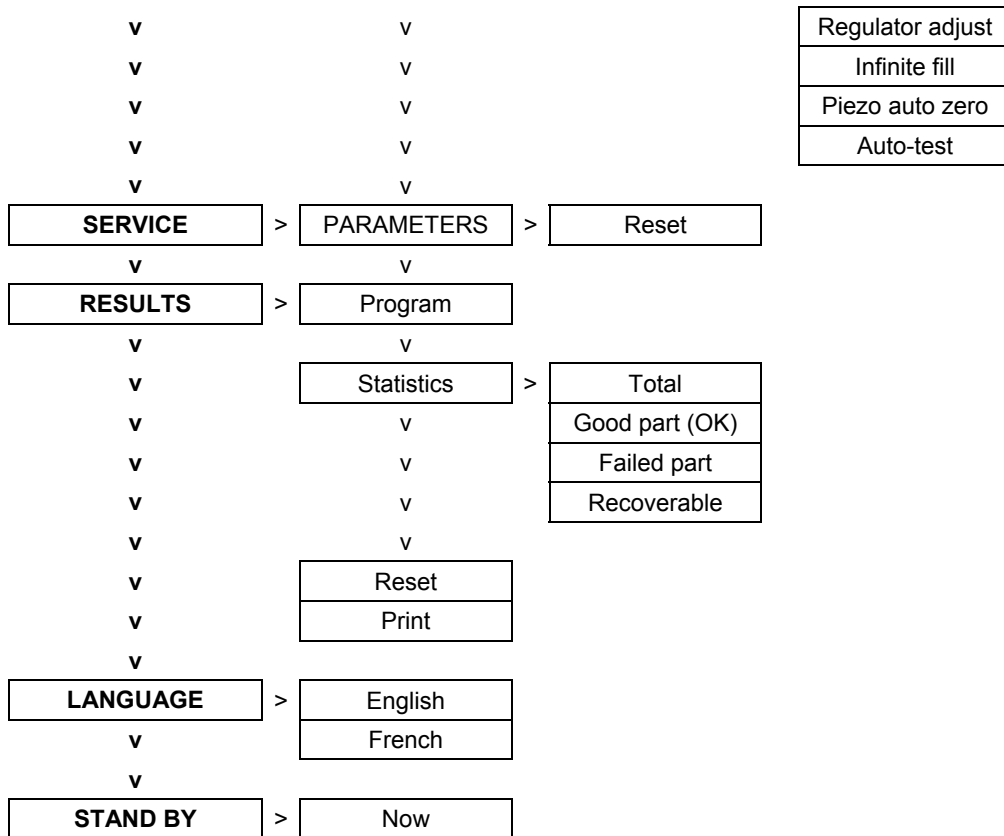

1.2. "FUNCTIONS" MENU WHEN ACTIVATED

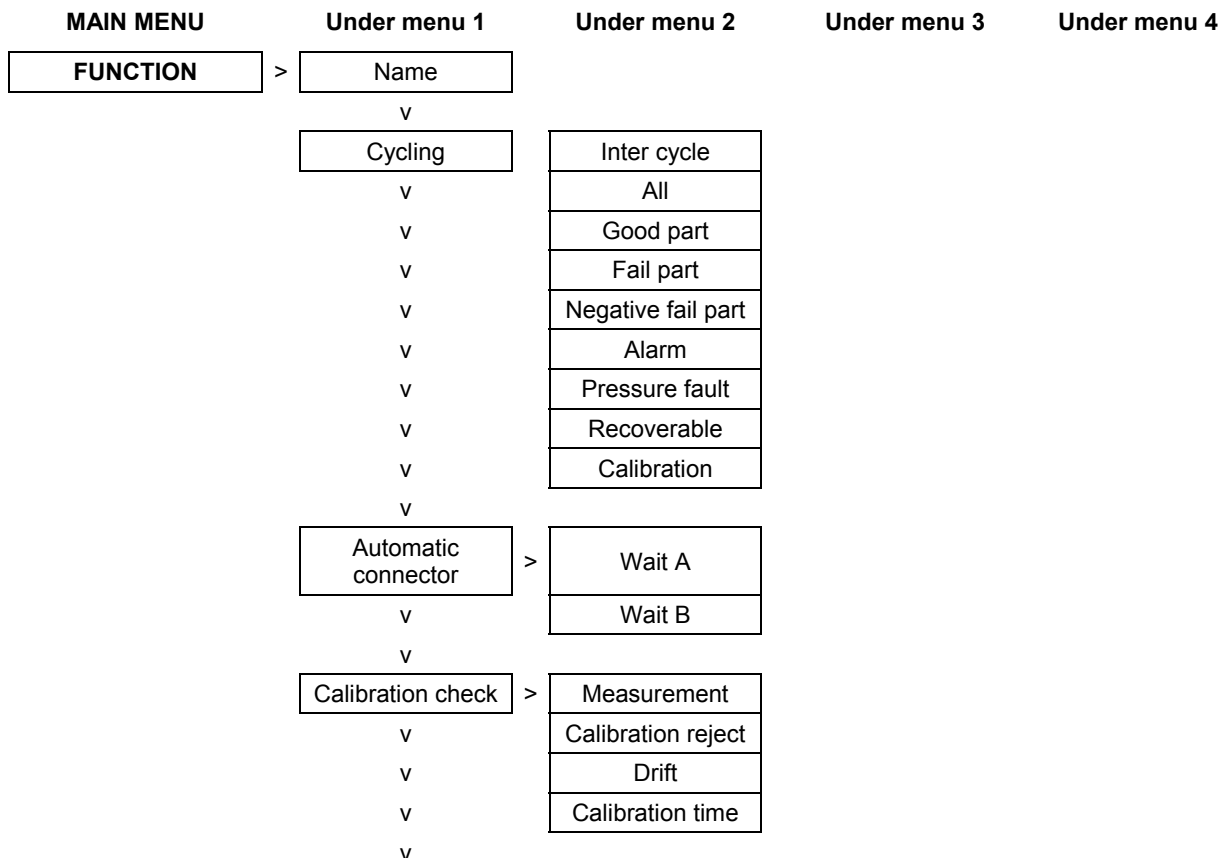

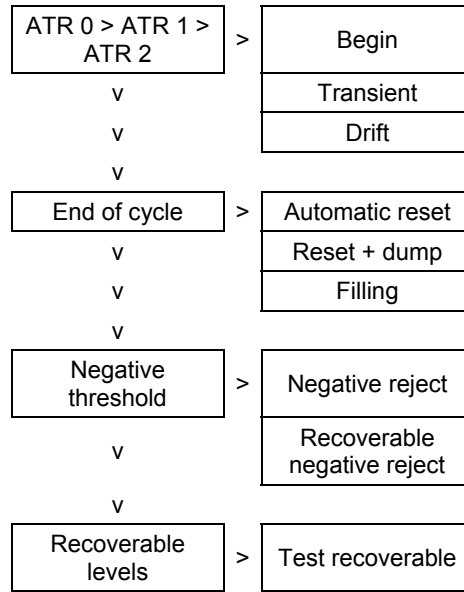









## 2. CONFIGURATION MENU

### 2.1. EXTENDED

The extended menus offer access to additional functions. If these functions are activated, they can be found in the **FUNCTION** menu when a program is created. If no additional functions are activated, the **FUNCTION** menu will be empty when a program is created.

#### 2.1.1. Activation of the additional functions

<p>In the main menu, place the cursor in front of the <b>CONFIGURATION</b> label</p>		<pre> MAIN MENU SPE CYCLE : Disabled CONFIGURATION RESULTS                     </pre>
<p>Confirm using the <b>ENTER</b> key.</p>		<pre> CONFIGURATION EXTENDED MENUS PRINTER : YES HOUR                     </pre>
<p>Next, confirm the <b>EXTENDED</b> function with the <b>ENTER</b> key. The list of additional functions is then displayed.</p>		<pre> CONF I/EXTEND MENUS NAME : No CYCLING : No AUTO CONNECT : No                     </pre>
<p>To activate a function (e.g. the <b>NAME</b> function), confirm it with the <b>ENTER</b> key. Next, choose <b>YES</b> with the navigation keys and confirm again with the <b>ENTER</b> key. Start the operation again if you need to activate other functions.</p>	   	<pre> CONF I/EXTEND MENUS NAME : Yes CYCLING : No AUTO CONNECT : No                     </pre>
<p>Once all the chosen functions are activated, press the <b>CANCEL</b> key twice to return to the main menu.</p>	 	<pre> MAIN MENU SPE CYCLE : Disabled CONFIGURATION RESULTS                     </pre>

### 2.1.2. Setting the additional functions

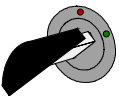
- ✓ Place the key in the **ACCESS** position .
- ✓ Create a new program (refer to chapter 3 paragraph 2 "Creation of a test program").
- ✓ In the parameters list for this new program, confirm the **FUNCTIONS** parameter (refer to chapter 3 paragraph 2.3 "Parameter setting").

 **Only the functions which have been activated using the above method will appear in the FUNCTIONS parameter.**

### 2.1.3. List of additional functions

#### 2.1.3. 1) Name

This function is used to customise a program, for example to name a program after the part to be tested.

 Select the option and enter settings if necessary.

#### 2.1.3. 2) Chaining

This function enables several tests to be carried out by the instrument one after the other. The instrument offers 8 program sequencing criteria.

The sequencing order can be edited; the choice of the following program is defined in the parameters. By default the programs are sequenced according to their original number P+1.

When an active program is sequenced with another program, a "+" is displayed behind the program number.

```

MAIN MENU
▶RUN PROG.      : 01+
PARAMETERS
SPE CYCLE : none
    
```

Associated parameters to be set: NEXT PROGRAM, INTER-CYCLE (wait or coupling time between two cycles). Chaining conditions: ALL RESULTS (under all result conditions), PASS (part good), TEST FAIL (test part bad), REFERENCE FAIL (reference part bad), ALARM, PRESSURE OUT (pressure error), REWORKABLE (parts which can be repaired), CALIBRATION (calibration error).

 Select the option and enter settings if necessary.

### 2.1.3. 3) ATR (Transient attenuation)

An ATR cycle enables time to be gained over a traditional cycle by enabling the stabilization time to be reduced and absorbing the transient pressure. The transient pressure is an unexpected drop in pressure caused by a stabilization time which is too short. The ATR may require a « learning » cycle to enable the transient pressure to be measured.

As the transient can evolve both negatively and positively, It is preferable to maintain identical Test and reference reject levels.

#### a) ATR 0

The initial value of the transient is known. Parameters must be set manually.

**The ATR may only be used on parts which have identical behaviour during the test, in other words, parts which have an identical transient.**

Associated parameters to be set: Initial (Initial value of the transient), Transit (actual, non modifiable value of the transient), Tolerance (Drift tolerance on acquisition of the transient, % of the reject level).

☞ Select the option and enter settings if necessary.

#### b) ATR1

The value of the transient is unknown. A special learning cycle must be carried out.

Associated parameters to be set: Initial (Initial value of the transient), Transit (actual and non modifiable value of the transient), Tolerance (Drift tolerance on acquisition of the transient, % of the reject level).

☞ Select the option and enter settings if necessary.

#### c) ATR2

Corresponds to ATR 1 but the potential leakage of the part is taken into account when the value of the transient is determined during the special cycle.

Associated parameters to be set: Initial (Initial value of the transient), Transit (actual and non modifiable value of the transient), Tolerance (Drift tolerance on acquisition of the transient, % of the reject level).

☞ Select the option and enter settings if necessary.

**For ATR learning cycles, see paragraph 3.6. "ATR learning".**

When a parameter is modified but no learning cycle has been carried out, an **"ATR"** error occurs. The **"alarm"** and **"end of cycle"** outputs are activated.



Learning may be carried out on a value greater than the reject level and the **"Pass"** and **"end of cycle"** outputs are then activated. However, the **"ATR"** fault appears if the difference between the transient and the initial value is greater than the reject level.

### 2.1.3. 4) Cycle end

This function enables different cycle ends to be chosen, depending on the configuration of the instrument (connection to a PLC).

#### a) Relay sequencing related to different cycle ends

In order to interface the **ATEQ F405** with its environment (PLC, PC ...), the following timing charts supply the details of the sequencing of the electrical outputs (relay board on the J3 connector) and pneumatic outputs (automatic connectors), depending on the commands entered on the front panel or through the J3 connector (START, RESET).

Legend	
<b>A</b>	Wait time for automatic connector A
<b>B</b>	Wait time for automatic connector B
<b>F</b>	Fill time
<b>S</b>	Stabilization time
<b>#</b>	Unspecified time occurring between the programmed test time and the pressing of the reset  key.
<b>T</b>	Test time
<b>D</b>	Dump time
<b>START</b>	Press the  key on the front panel or make a contact between pins 2-3 on the J3 connector.
<b>RESET</b>	Press the  key on the front panel or make a contact between pins 1-2 on the J3 connector.
<b>Automatic Connector</b>	Active (high level) : the pneumatic output is active (air output) Inactive (low level) : the pneumatic output is inactive (no air output)
<b>BP or GP</b>	Bad part or Good part relay on the J3 connector
<b>EoC</b>	End of cycle relay on J3 connector
<b>t mini</b>	Minimum time to accept an entry, 500 ms on connector J8 in the central module and 50 ms on connector J3 on a head.



**Actual times are not those displayed but those on the print-out.**

**b) "Automatic RESET" cycle end**

If the part is OK, the Part OK relay will be activated as soon as the test ends and remains so until the start of the following cycle. Following the dump time, the end of cycle relay is activated.

If the part is bad, the bad part relay is activated as soon as the test is completed. The instrument automatically dumps and sends a cycle end signal. A new cycle can then be launched.

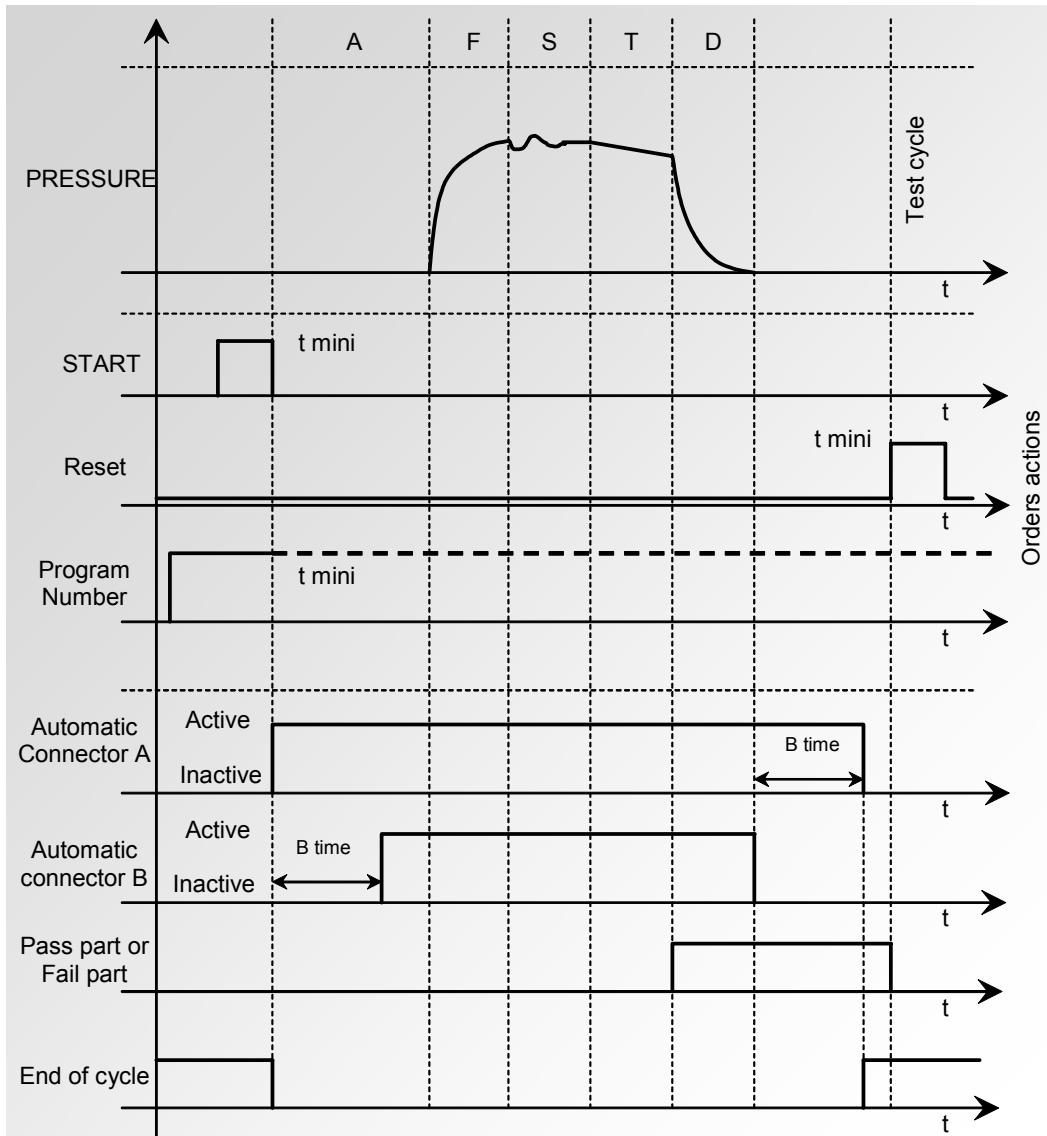

The active program is the one selected before starting up. It remains active even if the program inputs on the connector are no longer activated. This selection can only be modified during the inter cycle period.

To return to program 1, when a cycle is not in progress, press any of the program selection inputs.

**c) Ending a cycle with the RESET key ("Automatic RESET"  
Cycle end)**

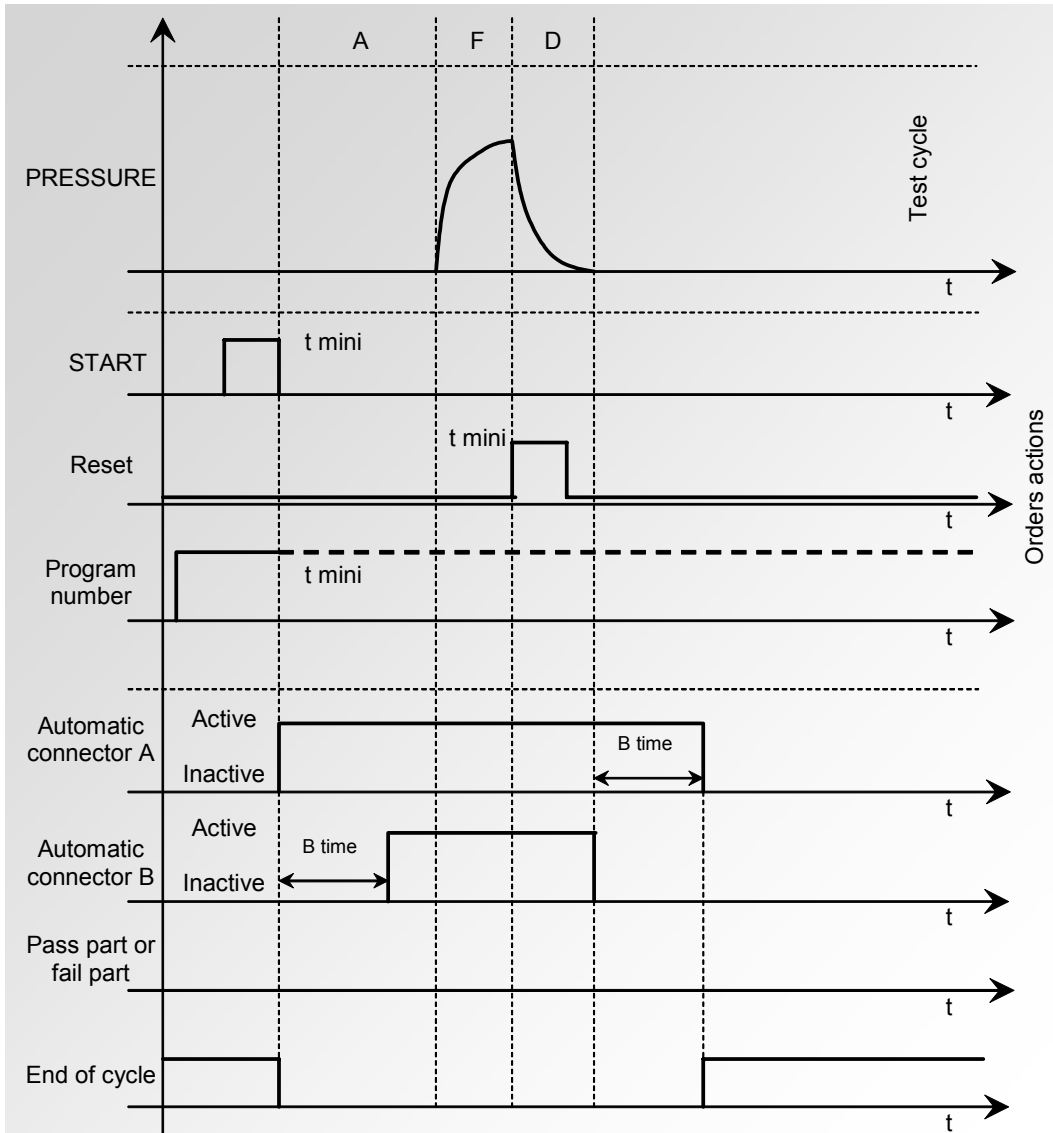

The active program is the one selected before starting up. It remains active even if the program inputs on the connector are no longer activated. This selection can only be modified during the inter cycle period.

To return to program 1, when a cycle is not in progress, press any of the program selection inputs.

**d) "RESET + dump" cycle end (automatic dump)**

If the part is OK, the part OK relay is activated as soon as the test time is finished, and remains so (only in position 2) until the next cycle is launched.

At the end of the dump time, the end of cycle relay is activated.

If the part is Bad, as soon as the test time is over, the bad part relay is activated and remains so until the end of the cycle. The dump is then carried out. The cycle can be

ended by pressing the **RESET**  key.

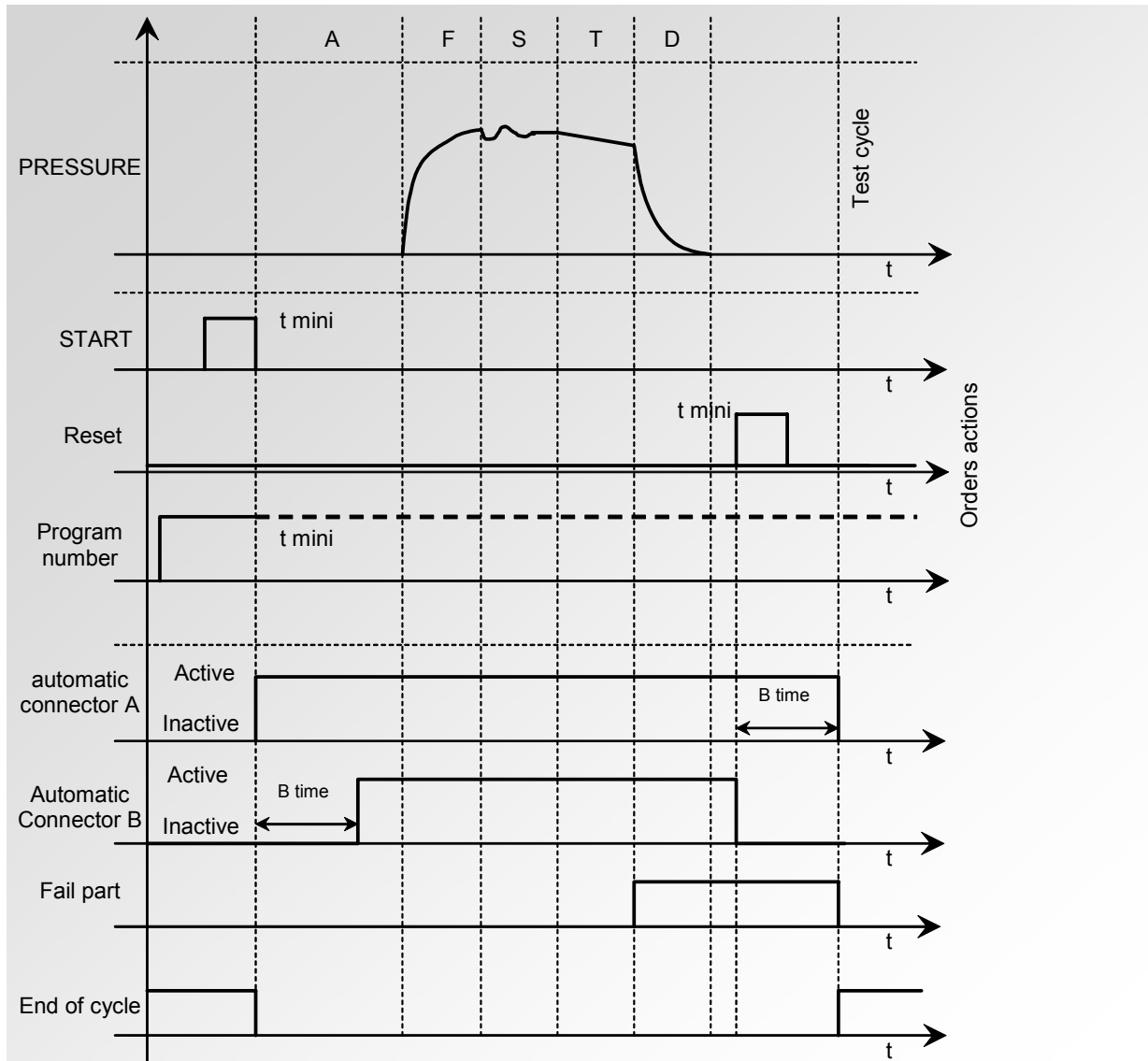

The active program is the one selected before starting up. It remains active even if the program inputs on the connector are no longer activated. This selection can only be modified during the inter cycle period.

To return to program 1, when a cycle is not in progress, press any of the program selection inputs.

e) "Fill" cycle end

If the part is OK, the good part relay is activated at the end of the test time and remains so till the start of the next cycle.

At the end of the dump time, the end of cycle relay is activated.

If the part is bad, as soon as the test time is finished the relay becomes and remains activated.

The instrument waits for a reset from the operator or the PLC to start the dump time and send the end of cycle signal.

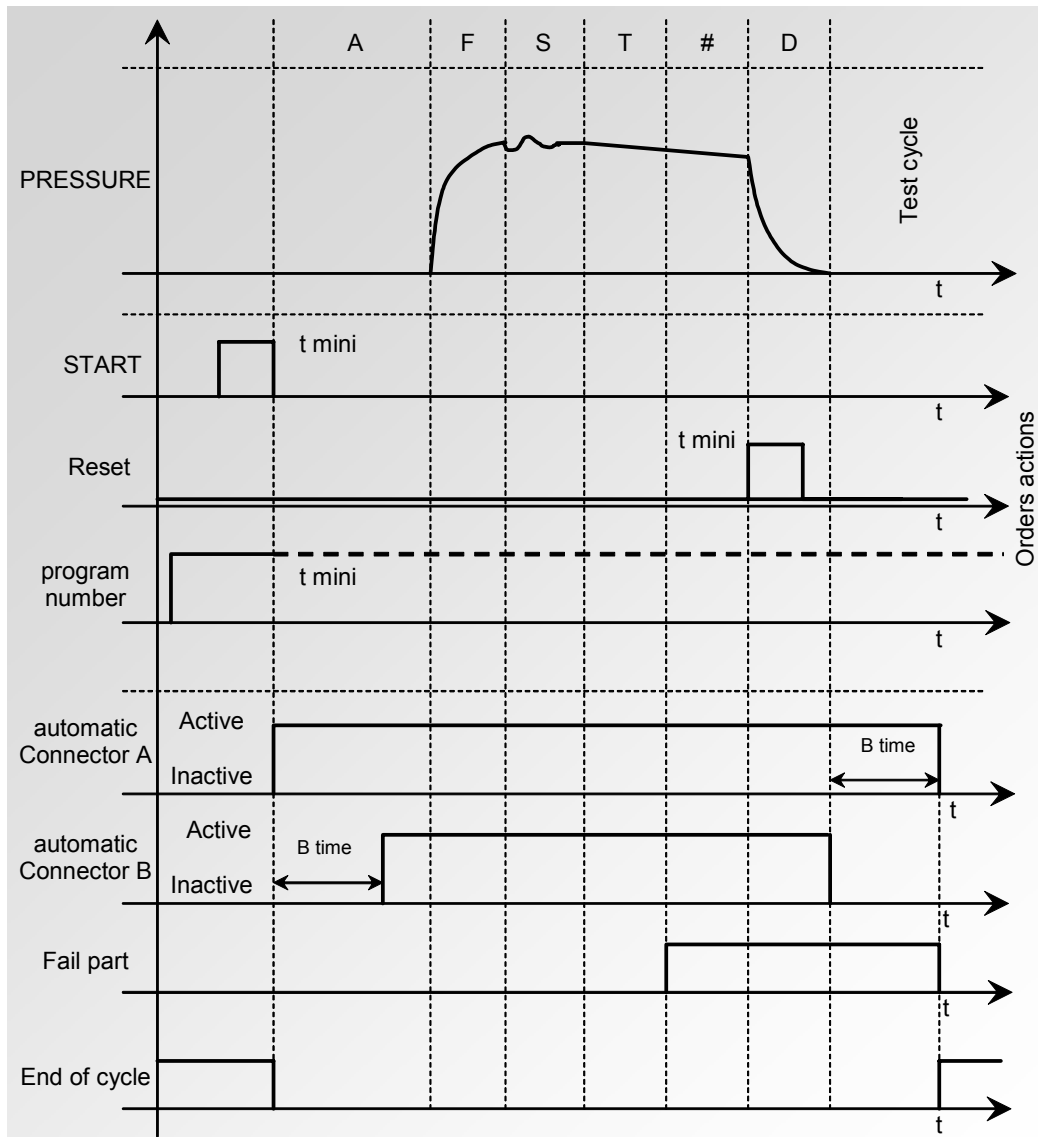

### 2.1.3. 5) Negative threshold

This parameter allows the setting of a reject level for a leak of "negative" conventional value. This type of leak is uncovered in the event of vacuum condition tests or in pressure measurement due to changes in the ambient temperature.

☞ Select the option and enter settings if necessary.

### 2.1.3. 6) Recovery limits

This option offers the option of two reject levels: non-tolerance level (the bad part is not recoverable) and recoverable reject level (the part is bad but may be reworked to become acceptable). This option is particularly used in casting, when parts are intended for treatment via impregnation.

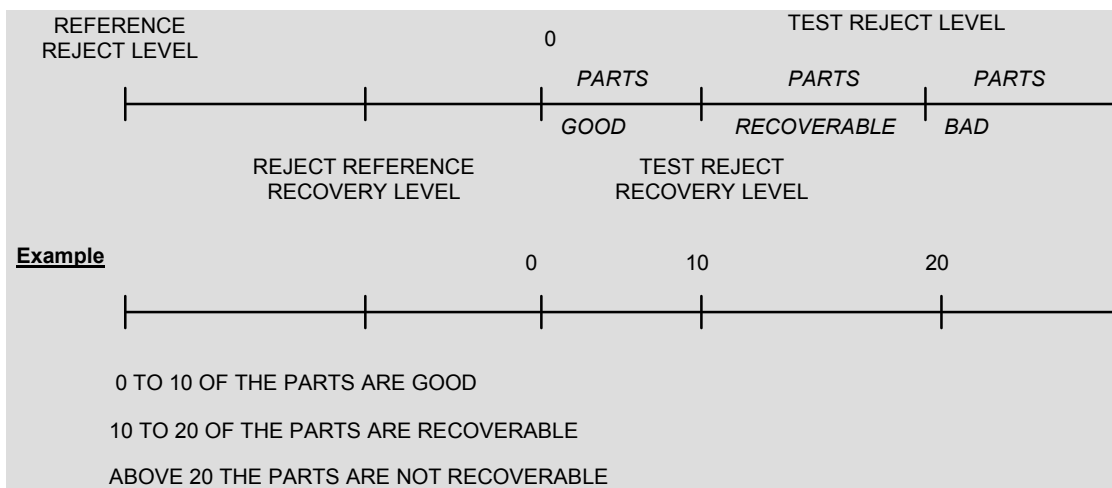

The associated parameters to be set are: RECUP Test.

For recoverable parts, with multi-head configuration on the central unit or on the heads themselves, the Pass (PB) and Fail (PM) outputs are both activated simultaneously.

☞ Select the option and enter settings if necessary.

## 2.2. RS232

### 2.2.1. C540/580

This function enables the configuration of the instrument so that it may be supervised by an ATEQ central module.

☞ Select the option and enter settings if necessary.

### 2.2.2. Print frame

Not operational.

### 2.2.3. Printer

This function enables the configuration of the instrument to enable the printing of the program data (parameters) as well as the test results. When the option is activated (YES), each time a cycle is started, the test results are systematically printed.

☞ Select the option and enter settings if necessary.

#### 2.2.3. 1) RS parameters

These parameters enable the configuration of the instrument enabling it to communicate with the printer.

Associated parameters to be set: Speed, Stop byte, number of data bytes, parity.

☞ Select the option and enter settings if necessary.

#### 2.2.3. 2) Print frame

This function enables the configuration of the results printout.

Associated parameters to be set: PRESSURE (Display or not of the test pressure), Prog. name (Display of the program name when set), Lines before (number of lines before the result), Lines after (number of lines after the result), Inter line (space between each line), Form feed (new page).

#### 2.2.3. 3) Frame format

The results frame is based on 40 columns.

##### a) Example for test OK result

1 2 3 4 5 6 7 8 9 10 11 12 13 14 15 16 17 18 19 20 21 22 23 24 25 26 27 28 29 30 31 32 33 34 35 36 37 38 39 40

< 0 1 > : ( O K ) : + 0 0 3 P a

Frame detail:

Columns	Characters
1	<
2-3	Figure indicating program number
4	>
5	:
6	(
7-8	2 letters indicating OK for good part TD bad test part RD bad reference part
9	)
10	:
11	SPACE
12	+, - or nothing
13 - 14 -15	3 figures indicating the leak value
16	SPACE
17 > XX	2 to 6 letters indicating the unit of measurement



### 2.2.6. Print parameters

When this option is confirmed the test parameters are printed immediately.

#### 2.2.6. 1) Example of parameter print frame

1	2	3	4	5	6	7	8	9	10	11	12	13	14	15	16	17	18	19	20	21	22	23	24	25	26	27	28	29	30	31	32	33	34	35	36	37	38	39	40	
V	e	r	s	i	o	n		0	1	.	0	1	t																											
P	r							0	1																															
T	Y	P	E		:		L	E	A	K																														
W	A	I	T		A	:		0	0	.	1	s	1	s																										
F	I	L	L		:		0	1	.	0	s																													
S	T	A	B		:		0	1	.	0	s																													
T	E	S	T		:		0	2	.	0	s																													
D	U	M	P		:		0	1	.	0	s																													
M	a	x	.	F	I	L	L	:			2	.	4	0																										
M	i	n	.	F	I	L	L	:			1	.	6	0																										
T	e	s	t	R	E	J	E	C	T	:			0	1	0																									
R	e	f	.	R	E	J	E	C	T	:			0	0	0																									

### 2.3. SECURITY

This function deactivates the **START** and **RESET** keys on the instrument front panel. Programs can only be started from the instrument inputs (J3 connector).

☞ Select the option and enter settings if necessary.









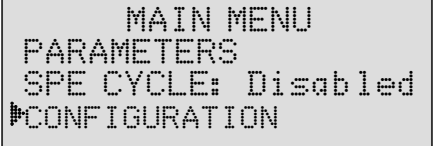

## 2.4. LIGHTING THE SCREEN

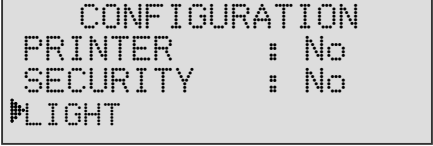
Screen illumination can be programmed and modified. The lighting can be adjusted according to the ambient conditions or the user's choice.

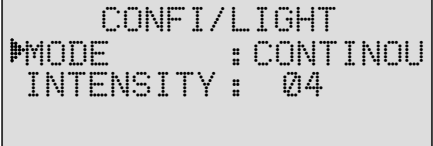
There are three lighting modes :

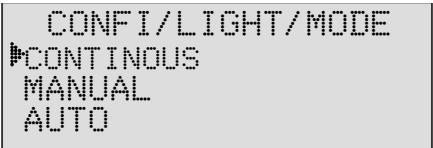
- ✓ **continuous** mode, display screen permanently lit whatever the conditions
- ✓ **manual** mode, the screen remains lit for 20 minutes and if the keyboard has not been used by the end of this period the screen shuts down and only relights when the keyboard is touched again.
- ✓ **automatic** mode, which is identical to manual mode, with illumination of the screen also if an action is carried out from the external inputs (rear connectors)

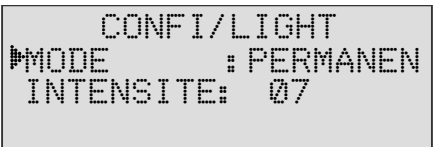
Using these three modes, the lighting intensity of the screen can be programmed from 00 (screen off) to 07 (maximum lighting intensity).

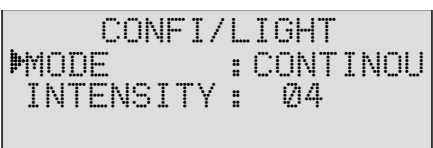
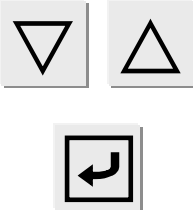
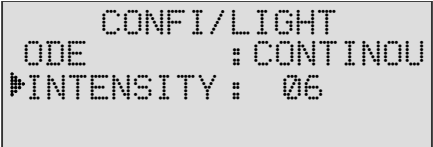



<p>In the main menu, position the cursor by the <b>CONFIGURATION</b> menu then confirm by pressing <b>ENTER</b> .</p>		
<p>Move the cursor down until it is in front of the <b>LIGHT</b> menu then confirm by pressing <b>ENTER</b>.</p>		
<p>Place the cursor in front of <b>MODE</b> to choose the required lighting mode and confirm using <b>ENTER</b>.</p>		
<p>Select the lighting mode and confirm using <b>ENTER</b>.</p>		
<p>To return to the previous menu, press the <b>C</b> button once</p>		
<p>To select the lighting intensity for the display, place the cursor in front of the <b>INTENSITY</b> menu and confirm using <b>ENTER</b>.</p>		
<p>Then select the lighting intensity from 00 (off) to 07 (maximum luminosity) and the new lighting intensity will be applied as soon as <b>ENTER</b> is pressed.</p>		

## 2.5. DUMP LEVEL

A message "**Part under pressure**" is displayed and the instrument don't gives the cycle end status if at the end of the dump time the pressure of the tested part is higher than the configured threshold.

```
CYCLE/Pr : 001
PRESS = 0.500 bar
PART UNDER PRESSURE
DUMP
```

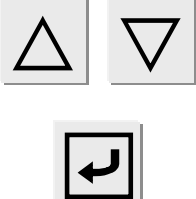
This function is parameterized in the "**Configuration**" menu.

<p>In the main menu, position the cursor by the <b>CONFIGURATION</b> menu then confirm by pressing <b>ENTER</b>.</p>		<pre>MAIN MENU PARAMETERS SPE CYCLE: Disabled DUMP LEVEL : No</pre>
<p>Move the cursor down until it is in front of the <b>DUMP LEVEL</b> menu then confirm by pressing <b>ENTER</b></p>		<pre>CONFIGURATION SECURITY : No LIGHT DUMP LEVEL : No</pre>
<p>Validate by <b>YES</b> the <b>DUMP LEVEL</b> function.</p>		<pre>CONFIGURATION SECURITY : No LIGHT DUMP LEVEL : Yes</pre>
<p>Then adjust the minimal dump level monitoring pressure, when the pressure in the tested part will be less than this threshold, the "End of cycle" output will be activated.</p>		<pre>CONF/DUMP LEVEL PRESSURE : 0.005</pre>
<p>To return to the previous menu, press the <b>C</b> button twice.</p>		<pre>MAIN MENU PARAMETERS SPE CYCLE: Disabled DUMP LEVEL : No</pre>

## 2.6. I/O CONFIGURATION

### 2.6.1. Input 5 (IN5)

This menu is used to configure programmable input 5 on connector J3 on the 16-program input/output board.

Refer to Chapter 1, paragraph 2.3.2.2) "Connector J3 (binary Inputs/Outputs) programmable input".

The various functions which can be set on input 7 are: "Program selection", "Valve Auto-test", "Regulator adjust", "Infinite fill", "Piezo auto zero".

These functions represent all the special cycles available.

**NB:** *to activate one of these functions, it must activate the input 5 (IN5) and the operator is pressing simultaneously the "Start" key.*





*If the current run program is not created, none of these functions appears in the "I/O Configuration" menu, only the program selection menu is accessible.*

### 3. SPECIAL CYCLES MENU

#### 3.1. SPECIAL CYCLES AVAILABLE







The following list shows all the special cycles which are possible those available will vary depending on what is checked in the expanded menus or according to the optional extras requested at the time of manufacture of the instrument.

Special cycle	Function
✓ Inactive	No special cycle selected.
✓ Regulator adjust	Cycles used to set the regulator.
✓ Infinite fill	Cycle used to put test part under pressure for infinite time.
✓ Piezzo auto reset	Cycle used to carry out forced reset of the piezzo transducer and the electronic regulator.
✓ Calibration check by volume	Cycle started manually by the operator to carry out calibration check by volume with a good part.
✓ CAL learning	This cycle is used to carry out learning in calibrated Pascal or Pascal/sec mode on a known standard leak.
✓ CAL check	This cycle is used for auto-diagnostics in calibrated Pascal mode (see previous function) within a tolerance determined by percentage limits.
✓ ATR learning	This cycle is used to enter the ATR parameters if they are not known. This should be done after each start-up of the instrument, or after a long period with no test cycles.
✓ Ato test	Allows to make an internal self control of the instrument, it's a non presence internal valves leaks checking.

To run a special cycle, select it in the "special cycles" menu, then press the  button. To stop it, press the  button. In some cycles the stop is automatic.

### 3.2. REGULATOR

This special cycle enables the main regulator pressure to be set.

Position the cursor in front of <b>SPE CYCLE</b> and confirm using the <b>ENTER</b> key.	 	<pre>SPE CYCLE Disabled Regulator adjust Infinite fill</pre>
Next , position the cursor in front of Regulator adjust and confirm using the <b>ENTER</b> key.	 	<pre>SPE CYCLE Disabled Regulator adjust Infinite fill</pre>
The display confirms that the special cycle has been selected.		<pre>MAIN MENU RUN PROG.: 005 PARAMETERS SPE CYCLE: Regul</pre>
Press the <b>START</b> key to start the special cycle.		<pre>RUN/Pr : 001 PRESS = 355.5 mbar  REGULATOR 1 ADJUST</pre>
Adjust the value of the pressure.		<pre>RUN/Pr : 001 PRESS = 500.0 mbar  REGULATOR 1 ADJUST</pre>
Once the pressure is adjusted, press the <b>RESET</b> key to stop the special cycle.		<pre>RUN/Pr : 001 PRESS = 0.000 bar  READY</pre>

**Note:** In the case of a test on empty, the negative pressure levels retain their mathematical "order".

#### PRESSURE MEASUREMENT

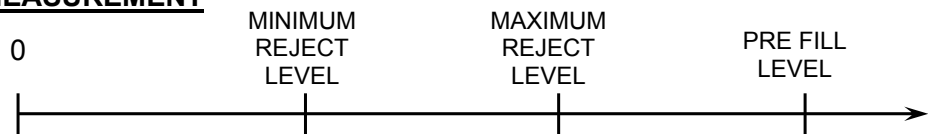



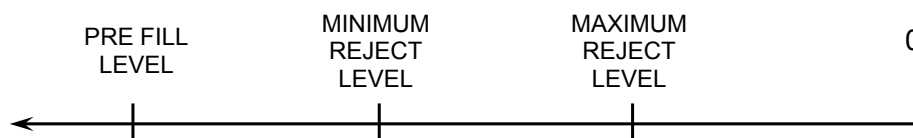



#### EMPTYING MEASUREMENT

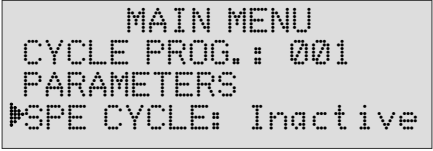

### 3.3. INFINITE FILL

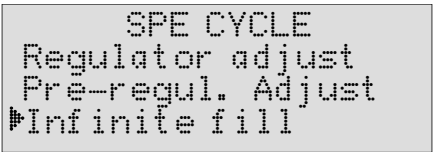
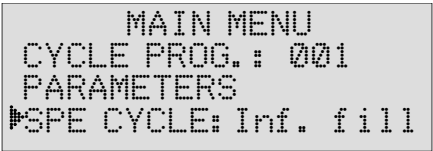

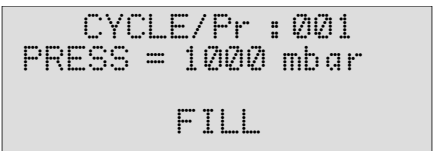

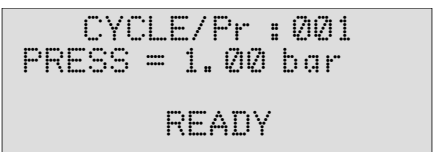
It is possible to carry out an infinite fill with the instrument, in other words, a permanent flow of air at the test pressure in order to locate leaks (set-up adjustment...).

If the assembly allows it (risk of sudden disconnection of part under pressure) it is preferable, in the case of infinite fill, to have a dump time of zero so as not to draw in liquid if there is a leak (when looking for leaks using a soapy water based product).

<p>In the main menu, place the cursor in front of the <b>SPE CYCLE</b> function and confirm using the <b>ENTER</b> key.</p>		
<p>Next, place the cursor in front of <b>Infinite fill</b> and confirm using the <b>ENTER</b> key.</p>		
<p>The display confirms that the special cycle has been selected.</p>		
<p>Press the <b>START</b> key to start a new cycle.</p>		
<p>Adjust the test pressure.</p>		
<p>To stop the cycle, press the <b>RESET</b> key.</p>		

### 3.4. PIEZZO RESET

Used for compulsory reset to zero of the piezzo sensor.

<p>In the main menu, place the cursor in front of <b>SPE CYCLE</b> and confirm using <b>ENTER</b>.</p>	 	<pre> MAIN MENU RUN PROG: 001 PARAMETERS ▶SPE CYCLE: Inactive                     </pre>
<p>Next, place the cursor in front of <b>Piezzo Reset</b> function and confirm using <b>ENTER</b>.</p>	 	<pre> SPE CYCLE Pre-regul. adjust Infinife fill ▶Piezo reset                     </pre>
<p>The display confirms that the special cycle has been selected.</p>		<pre> MAIN MENU RUN PROG.: 001 PARAMETERS ▶SPE CYCLE: Piezo R.                     </pre>
<p>Press the <b>START</b> key to start the reset.</p>		<pre> RUN/Pr : 001 PRESS = 355.5 mbar  RESET                     </pre>
<p>Once the reset is carried out, the cycle ends automatically.</p>		<pre> RUN/Pr : 001 PRESS = 355.5 mbar  READY                     </pre>

### 3.5. MANUAL CALIBRATION

#### 3.5.1. CAL Learning (calibration)

If the 4 units of flow are not appropriate for the application, it is possible to go to calibrated mode (manual). To do this, a learning cycle must be carried out so that a calibration value will correspond to a pressure drop.





To access this special cycle, select the unit **Cal-Pa** or **Cal-Pa/s** as a reject unit when creating a program (for selection of units, see chapter 3 § 2.3 "Setting parameters").

Then the special learning cycle must be carried out, either from the special cycles menu or from input 7 on connector J3 programmed for this function, or via a programmed function key on the optional RC5 keypad, if this is installed.

The first CAL learning cycle must be done using the special cycles menu so that a CAL target which is different to zero can be entered.

On these outputs we have:





- "Pass" and "end of cycle" if the target is lower than or equal to the test reject level,
- "Fail" and "end of cycle" if the target is greater than the test reject level.

<p>In the main menu, place the cursor in front of the <b>SPE CYCLE</b> function and confirm using the <b>ENTER</b> key.</p>		<pre> MAIN MENU RUN PROG.: 001 PARAMETERS SPE CYCLE: Disabled                     </pre>
<p>Next, place the cursor in front of the <b>CAL. learn</b> function and confirm using the <b>ENTER</b> key.</p>		<pre> SPE CYCLE Infinite fill Piezo reset CAL. Learn.                     </pre>
<p>The display confirms that the special cycle has been selected.</p>		<pre> SPE C/CAL. Learn INSTRUCT. : 0.0004 R. UNIT : Cal-Pa                     </pre>
<p>Set the target calibration <b>INSTRUCT</b> which will be used as the base unit using the navigation keys.</p>		<pre> SPE C/CAL. Learn INSTRUCT. : 0.0004 R. UNIT : Cal-Pa                     </pre>
<p>Confirm using the <b>ENTER</b> key, even if the value remains unchanged.</p>		<pre> MAIN MENU RUN PROG.: 001 PARAMETERS SPE CYCLE: Cal                     </pre>
<p>Press the <b>START</b> key to start the learning cycle. At the end of the cycle, the readout displays the test results in the calibration unit.</p>		<pre> CYCLE/Pr : 001 PRESS = 0.505 bar LEAK = 1.5 Cal-Pa READY                     </pre>
<p>Once carried out, the calibration cycle will end of its own accord.</p>		<pre> CYCLE/Pr : 001 PRESS = 355.5 mbar  READY                     </pre>

**Note:** The CDF (leak flow calibrator) can be used to calibrate the instrument and to send this value via the infra-red link.





### 3.6. ATR LEARNING

If the transient values are not known, a transient learning cycle must be carried out so that the instrument can calculate and enter the values. These learning cycles are located as shortcuts in the special cycle's menu, on input 7 of connector J3 programmed for this function or on a programmed function key on the optional RC5 keypad, if this is installed.

<p>If no transient learning has been carried out, the message <b>ATR ERROR</b> will appear.</p>		<pre> RUN/Pr: 001 PRESS = 1.50 bar LEAK = ATR ERROR READY (NO OK)                     </pre>
<p>To carry out the learning, select the <b>SPE CYCLE</b> menu.</p>		<pre> MAIN MENU RUN PROG. : 001 PARAMETERS MCYCLE SPE : Disabled                     </pre>
<p>Then select the <b>ATR Learn</b> menu.</p>		<pre> SPE CYCLE Infinite fill Piezo auto zero ATR Learn.                     </pre>
<p>The display confirms that the special cycle has been selected.</p>		<pre> MAIN MENU RUN PROG. : 001 PARAMETERS MCYCLE SPE : ATR                     </pre>
<p></p>		<pre> RUN/Pr: 001 PRESS = 1.50 bar LEAK = 002 Pa READY (OK)                     </pre>
<p>The instrument carries out a test cycle, then continues the cycle by carrying out a learning cycle. When the cycle has been completed, the transient values are recorded.</p>		<pre> RUN/Pr: 001 PRESS = 1.50 bar LEAK = 002 Pa ATR Learn.                     </pre>
<p>To view the transient values, press <b>ENTER</b>. <i>Note: these values can be modified manually.</i></p>		<pre> ATR2 Begin. : -000 Transient : -003 DRIFT : 020 %                     </pre>

### 3.7. AUTO-TEST

Allows to make an internal self control of the instrument, it's a non presence internal valves leaks checking.

<p>To carry out an auto test, it must select the <b>SPE CYCLE</b> menu.</p>	 	<pre>MENU PRINCIPAL PROG. ACTIF : 01 PARAMETRES CYCLE SPE: Inactif</pre>
<p>Then select the <b>Auto test</b> Menu.</p>	 	<pre>CYCLE SPE Auto zero piezo Apprent. CAL. Auto test</pre>
<p>The display confirms that the special cycle has been selected.</p>		<pre>MENU PRINCIPAL PROG. ACTIF : 01 PARAMETRES CYCLE SPE: Aut-test</pre>
<p>Press the <b>START</b> button to start the auto test cycle.</p>		<pre>CYCLE/Pr : 001 PRESS = 1.50 bar AUTO-TEST REPLISSAGE</pre>
<p>The instrument is carrying out the auto test cycle. Until the cycle is finished, it indicates the auto test result. If it indicates OK the auto test is good. If it indicates DT the auto test is fail, please contact the ATEQ After Sales Service to make an instrument checking.</p>		<pre>CYCLE/Pr : 001 PRESS = 1.50 bar AUTO-TEST FRET (PE)</pre>









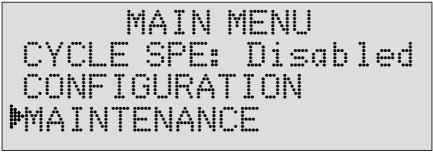

#### 4. MAINTENANCE MENU

This menu is used to manage the memory containing the test cycle parameters.

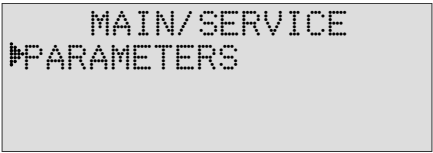
- ✓ Erase maintenance parameters menu: used to delete the current configuration.

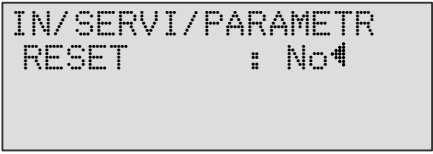
To access the menu, turn the key switch to the **ACCESS** position.

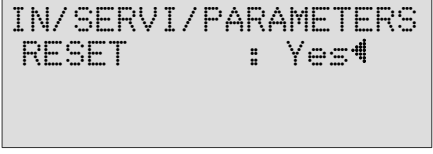

<p>In the main menu, place the cursor in front of <b>SERVICE</b> and confirm using <b>ENTER</b>.</p>	 	
<p>Then place the cursor in front of <b>PARAMETERS</b> and confirm using <b>ENTER</b>.</p>	 	
<p>Then place the cursor in front of the action required: <b>ERASE</b>: delete current parameters and return to initial configuration. and confirm using <b>ENTER</b>.</p>	 	
<p>To activate an operation, confirm using <b>ENTER</b>. Then choose <b>YES</b> using the arrows then confirm again using <b>ENTER</b>.</p>	  	

## 5. RESULTS MENU

This function is used for:

- ✓ the detailed display of the test results: number of parts tested, number of good parts, number of bad reference parts, number of bad parts, number of recovered parts, number of times the alarm is triggered (each indicator is expressed as a % value),
- ✓ the resetting of the results memory,
- ✓ printing of the results (number of good parts, number of bad parts. ).

## 6. LANGUAGE MENU

This function is used to select the language displayed by the instrument. Several languages are available. Two languages can be stored in the instrument when it is manufactured, English by default and one other optional language.

## 7. STAND BY MENU

This function is used to switch off the instrument without disconnecting it. Standby can be immediate or programmed with start and stop times.

There are two ways to achieve immediate standby:

Either through the standby menu,

Or by pressing the **RESET**  button for more than three seconds.

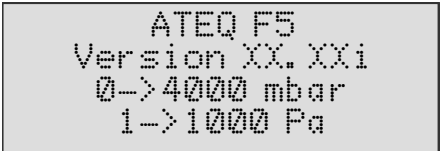
<p><b>Note:</b> when the instrument is on standby, the display is off.</p>		
<p>To reactivate the instrument, simply press any key on the front panel or activate any input.</p>		

 Select the option and enter settings if necessary.



## Chapter 5

---

# ACCESSORIES

---

### 1. ACCESSORIES SUPPLIED WITH THE INSTRUMENT

#### 1.1. POWER SUPPLY

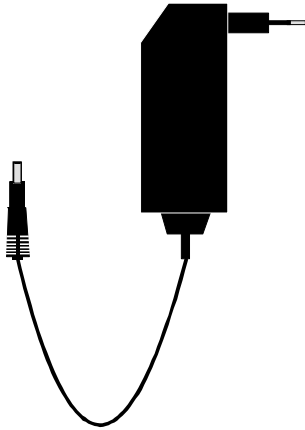

The power supply of the **F405** converts a network voltage (120 to 240 V AC) into a 24 V DC low voltage supply. It has no power switch and works as soon as it is plugged in. It is protected against surges and short circuits via a thermal fuse (Do not use any other type of fuse).

## 2. OPTIONAL ACCESSORIES

### 2.1. CALIBRATED LEAK

Calibrated leaks are used to check the instrument's calibration.

PRESSURE	Master leak type										
	A	B	5	C	D	50	E	F	G	1000	5000
<b>2 kPa</b> (20 mbar)			1,5	3,12	6,6	18	31,2	1,24	2,05	4,2	53
<b>5 kPa</b> (50 mbar)		2,3	4	7,4	17,5	42	1,3	2,6	5,25	11,3	132
<b>15 kPa</b> (150 mbar)	2,82	6,7	12	23	55	2,2	4	8,2	17	35,5	338
<b>30 kPa</b> (300 mbar)	4,8	12	24	46,8	2,12	3,6	7,6	22,4	40	74,5	700
<b>50 kPa</b> (500 mbar)	10	25	48	1,4	3,5	8	15,5	31	63	150	1142
<b>100 kPa</b> (1 bar)	23	56	1,8	3,3	8	19	37	74	149	360	2230
<b>200 kPa</b> (2 bar)	55	2,3	4,6	8,5	21	47	89	194	380	830	4343
<b>400 kPa</b> (4 bar)	2,5	6,6	12,1	23,3	56	125	220	540	1030	1500	8750
<b>1 MPa</b> (10 bar)	11,5	29	50	95	198	420	705	2310	3700	4450	

 **kPa.cm<sup>3</sup>/h**  
(bar.cm<sup>3</sup>/h)

 **kPa.cm<sup>3</sup>/min**  
(bar.cm<sup>3</sup>/min)

**Note:** the values indicated above are given for information and can vary by +/- 20%. The true rate is precisely measured before delivery with an accuracy of +/- 5% up to 1Mpa.cm<sup>3</sup>/min (10 bar.cm<sup>3</sup>/min) and +/- 3% from this value. **Special master leaks can be manufactured on request, within 5% of the requested value.**

- ✓ The calibrated leaks must be used with clean dry air.
- ✓ These leaks must not be dipped in water. It is essential that they are stored in their case after usage.
- ✓ The leaks must be checked periodically by the company's metrology department or by **ATEQ's** metrology service.
- ✓ Check that there is an O-ring seal and that it is in good condition.
- ✓ The instrument zero check must be done by replacing the leak with a sealing connector and not by sealing off the leak itself.
- ✓ To check that the leak has not been blocked, attach a piece of flexible tubing to the leak and submerge its extremity in water to watch for bubbles.

## 2.2. NEEDLE VALVE AND LEAK/FLOW CALIBRATOR (CDF)

### 2.2.1. Needle valve

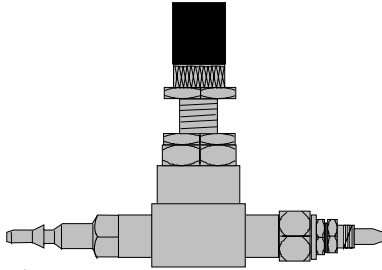

Needle valves are used to calibrate the leakage limits. These valves have an adjustable leak and depending on the model allow adjustments of between a few cm<sup>3</sup>/h to several l/min.

These valves can be easily disturbed and therefore require the frequent use of some means of checking the setting (ex: CDF).

**Note:** it is strongly recommended that you do NOT leave a needle valve permanently connected on a leak detection machine with automatic calibration every "n cycles".

### 2.2.2. CDF (Leak/flow Calibrator)

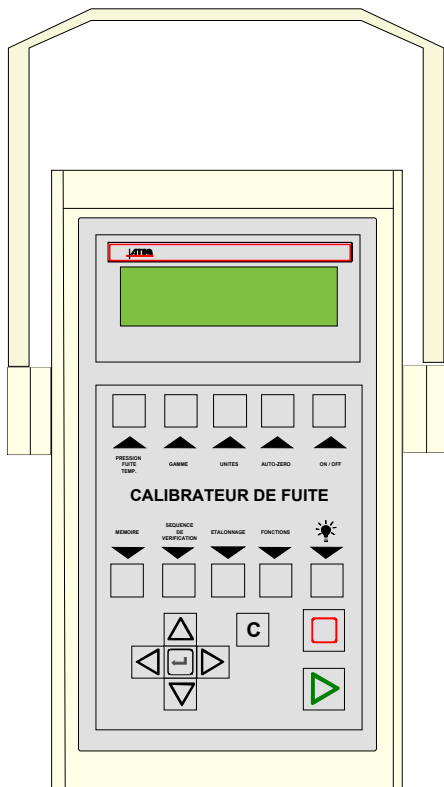

The **Leak/Flow calibrator** is a multiple range **ATEQ** flow meter intended for checking leak testing equipment and particularly **ATEQ** instruments. It measures a loss of charge with a differential sensor, which is connected to a calibrated flow tube.

### 2.3. AUTOMATIC CONNECTORS WITH EXPANDABLE JOINTS

**ATEQ** automatic connectors are used so that accurate and reliable assemblies can be built to check air tightness. They simplify the work of the operator as they are self-locking thanks to the use of a pneumatic valve supplied from the mains compressed air supply. Several connectors may be controlled by the same remote, powered by an **ATEQ** or other logic.

They adapt easily to a large number of fittings and apertures of varied dimensions. Their use ensures that non-machined walls can be guaranteed airtight.

There are four basic versions of **ATEQ** automatic connectors :

- ✓ SA for external connections,
- ✓ SI for internal connections,
- ✓ SAG and SIG for threaded and tapped connections.

They are either in anodised aluminium or stainless steel as standard. Different types of joints are available depending on the elasticity required.

#### 2.3.1. Operation

The connector is positioned manually or automatically using a jack or cylinder.

Compressed air is allowed through the control aperture via a three part valve. The pressure pushes the cylinder which squashes the connector. The air tightness is therefore perfect and there will be no leakage in the connector seals.

#### 2.3.2. Standard dimensions

SAG and SIG have been designed for threaded and tapped caps. For the time being, they are available in gas norm. Sizes, which are: 1/2", 3/4", 1", 1 1/4", 1 1/2", 2", BSP.

The SA and SI are designed for smooth nozzles, with dimensions from 3 to 80 mm for the external diameters (SA), and from 10 to 75 mm for the internal diameters (SI).

### 2.4. FILTRATION KIT

Clean, dry air must be used to ensure the reliability of the instruments.

The filtration kit is connected to the air input on the rear panel of the instrument.

It consists of a dust filtering cartridge (5µm) and other cartridge (0.01 µm) giving residual oil pollution equal to 0.01 ppm.

## Chapter 6

# ERROR MESSAGES

The **ATEQ F405** can display error messages if there are operational problems.

PROBLEM	MESSAGE DISPLAYED
<p>Test error. Leak in excess of the full scale.  <b>Action:</b> check the test circuit.</p>	<pre>CYCLE/Pr001 PRESS=0.942 bar LEAK=&gt;&gt;F. S TEST READY (NO OK)</pre>
<p>Pressure in excess of the full scale.  <b>Action:</b> decrease the pressure using the mechanical regulator knob or the target if an electronic regulator is used.</p>	<pre>CYCLE/Pr001 PRESS=&gt; FULL SCALE READY (NO OK)</pre>
<p>Pressure in excess of the maximum threshold.  <b>Action:</b> check regulator settings, pressure limits, check whether the right regulator has been selected if there are two.</p>	<pre>CYCLE/Pr001 PRESS=1.02 bar P&gt; READY (NO OK)</pre>
<p>Pressure below the minimum threshold.  <b>Action:</b> check the network pressure and regulator settings, the pressure limits, and whether the right regulator has been selected if there are two.</p>	<pre>CYCLE/Pr001 PRESS=0.000 bar P&lt; READY (NO OK)</pre>
<p>ATR error.  <b>Action:</b> run another ATR learning cycle or check the ATR parameters. ATR fault.</p>	<pre>CYCLE/Pr001 PRESS=0.942 bar LEAK=ATR ERROR READY (NO OK)</pre>
<p>Fault: no CAL learning  <b>Action:</b> carry out CAL learning</p>	<pre>CYCLE/Pr001 PRESS=0.942 bar LEAK=CAL DEFAULT READY (NO OK)</pre>
<p>or CAL drift found following request for CAL check.  <b>Action:</b> check the programmed percentage of CAL drift, the known standard leak and the test pressure.</p>	<pre>CYCLE/Pr001 PRESS=0.942 bar LEAK=CAL ERROR READY (NO OK)</pre>

PROBLEM	MESSAGE DISPLAYED
<p>The input pressure on the regulator must be at least 10 % of regulator full scale + 100kPa (+ 1 bar).  <b>Action:</b> check supply network pressure or pressure at the regulator input.</p>	<p>The indicator lights come on briefly after the following message is displayed :</p> <div data-bbox="1008 405 1442 551" style="border: 1px solid black; padding: 5px; text-align: center;"> REGULATOR ERROR </div>
<p>PROG error: the I/O's have selected a program with no parameters.  <b>Action:</b> enter program parameters.</p>	<div data-bbox="1008 618 1442 763" style="border: 1px solid black; padding: 5px; text-align: center;"> CYCLE/Pr.: 009 ERROR </div>
<p>Inappropriate size for the selected unit of pressure.  <b>Action:</b> change unit or modify the minimum and maximum pressure limits if these and the test pressure can be used with this unit.</p>	<div data-bbox="1008 831 1442 976" style="border: 1px solid black; padding: 5px;"> PARAM/Pr 001 &gt;Press. Unity: mbar MAX Fill : FFFF MIN Fill : 0.0 </div>

## Chapter 7

---

# OPERATIONAL PROBLEMS

---

### 1. PHENOMENON NOTED

If a test machine begins to detect too many bad parts (statistically, more than three consecutively), it is advisable to carry out a **check on the whole unit**. The quality of the manufacture and operation of the leak detector should be the last things considered.

#### 1.1. CONDITION OF THE MACHINE'S SEALS

This is the no.1 defect as the seals are subject to high levels of dirt contamination (alumina, shavings). Regular cleaning of the seals is an effective remedy.

#### 1.2. DAMAGED INSTRUMENT SEALS

There is a possibility that the seals may be cut by shavings or worn by repetitive squashing. This can be prevented by regular servicing and replacement of the seals.

#### 1.3. BUMPER PAD

This is a defect which may occur after a certain amount of time as the bumper pads may be worn, or if the pressure settings in the air cylinder are inadvertently disturbed. Check the stability of the measurement and that the bumper pads are correctly installed.

#### 1.4. PNEUMATIC AIR SUPPLY TOO LOW

This anomaly can cause false measurements (large leaks or erratic measurements). The air supply to the cells must be higher than the minimum of 4 bar and it is essential that it is greater than the minimum test pressure of 1 bar. Also check that sealing connectors are being used correctly.

#### 1.5. PNEUMATIC LINK

The link and reference pipes will age and break with time. The pipes and seals must conform to the required quality. **ATEQ** recommends the use of RILSAN PA11 pipes and AVS type joints.

## 1.6. ENVIRONMENT

A measurement may be affected by a variation in background temperature (sun, draughts, storage of parts outdoors, handling of the test part by the operator, ...).

The dampness of parts may cause errors in the readings (insufficient drying after washing, outdoor storage, condensation, presence of water in the fixture, ...).

## 1.7. CALIBRATION

**ATEQ** does not accept any liability in regard to calibrations and settings to its instruments which are not carried out by its own personnel.

## 1.8. CONCERNS ABOUT RELIABILITY OF THE INSTRUMENT'S CIRCUITS

If all the other checks do not resolve the problem, the instrument's circuit may be checked.

Proceed as follows:

- ✓ Segregate the instrument from its environment (pneumatic assembly),
- ✓ Connect up the instrument (test output),
- ✓ Choose an unused program,
- ✓ Set the parameters as follows:
  - ⇒ the regulator to the test pressure,
  - ⇒ the pressure monitoring thresholds to +/- 20 % of the test pressure,
  - ⇒ wait times A and B 0 seconds,
  - ⇒ fill time 4 seconds,
  - ⇒ stabilisation time 10 seconds,
  - ⇒ test time 10 seconds,
  - ⇒ dump time 1 second,
  - ⇒ reject level maximum,
  - ⇒ unit Pa/sec,
  - ⇒ function all functions cancelled.

Run two consecutive cycles.

The post test time result should not exceed 4 Pa/sec.

## Appendices

---

### ATEQ F405

---

#### 1. TECHNICAL CHARACTERISTICS OF THE F405

	<b>F405</b>
<b>Case dimensions</b> H x L x D (mm) :	120 x 240 x 100
<b>Remote control dimensions</b> H x L x D (mm) :	33 x 178 x 126
<b>Power supply :</b>	24 VDC / 1,6 A Min 23,5 V ; Max 28 V
<b>Pneumatic connections :</b>	Supply: 6/8. Test: 4/6.
<b>Weight (kg) :</b>	About 3
<b>Temperatures :</b>	
Operational :	+10°C to +45°C
Storage :	0°C to +60 °C

## 2. MECHANICAL DEFINITION DRAWINGS OF F405

### 2.1. PNEUMATIC CASE

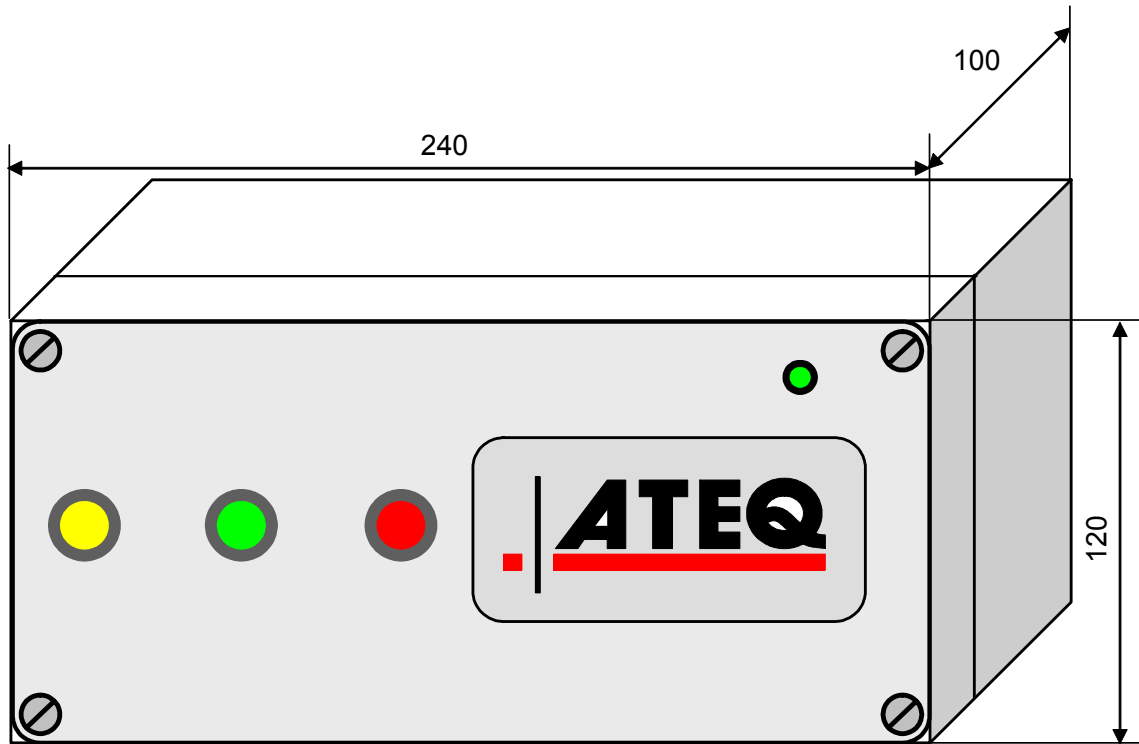

### 2.2. CASE INSTALLATION

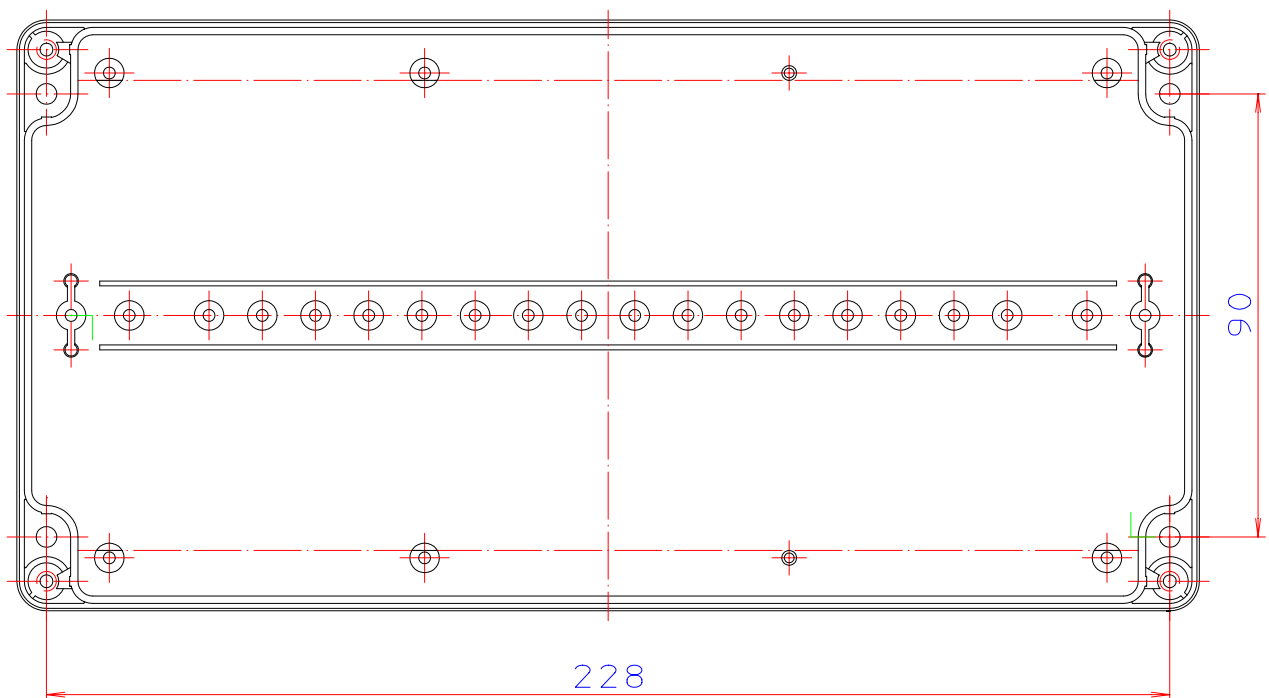

Detail of facing for the case installation:

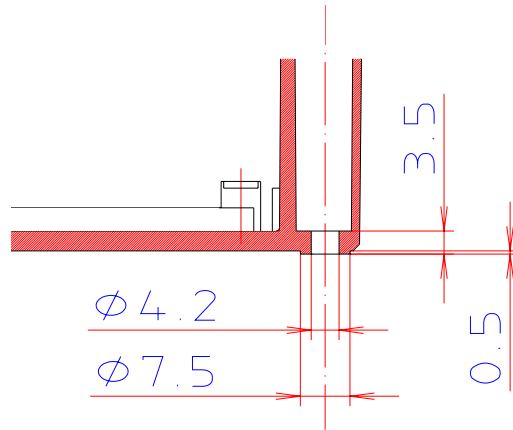

### 2.3. REMOTE CONTROL

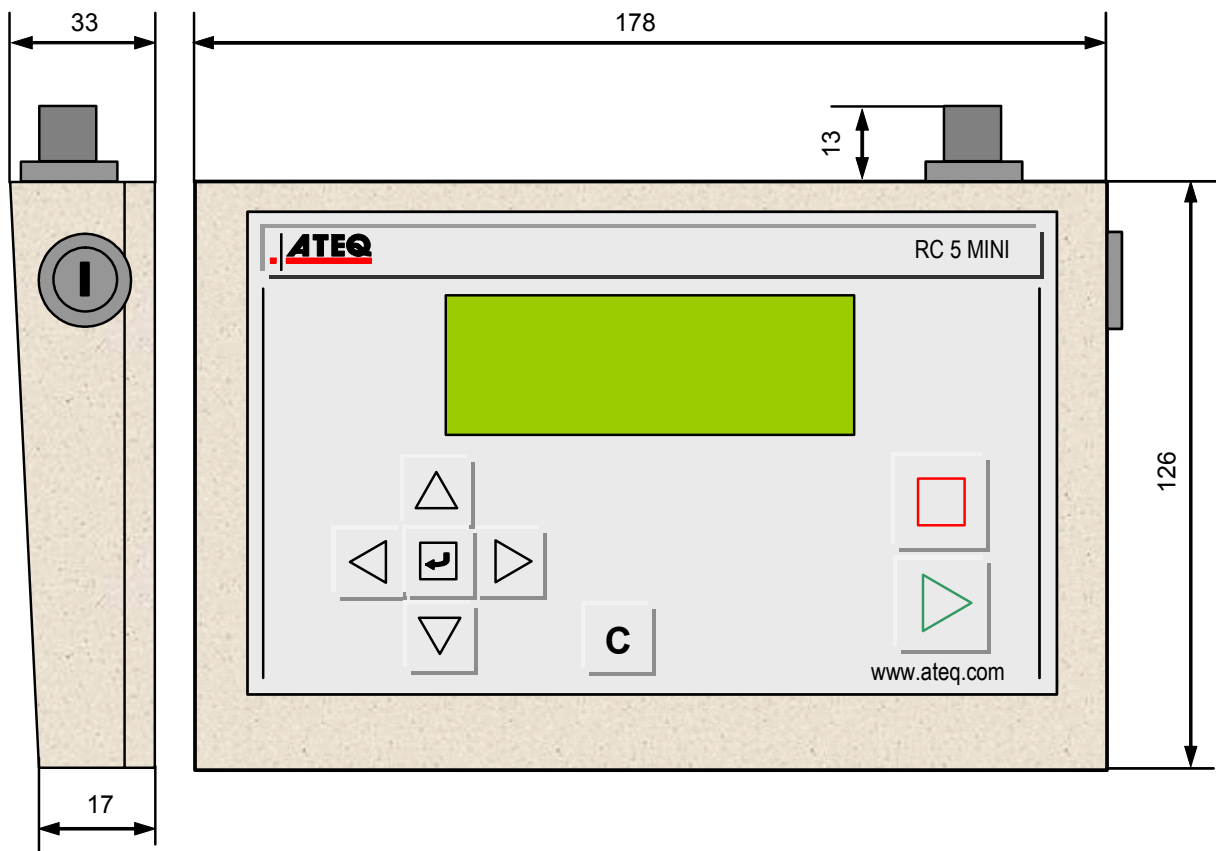

### 3. CONVERSION TABLE

		TO									
		Pa	kPa	bar	mbar	mmH2O	atm	Torr	psi	inH2O	inHg
FROM	Pa	1	10 <sup>-3</sup>	10 <sup>-5</sup>	10 <sup>-2</sup>	0.10197	9.8692 10 <sup>-6</sup>	7.5 10 <sup>-3</sup>	1.45 10 <sup>-4</sup>	4.01 10 <sup>-3</sup>	2.95 10 <sup>-4</sup>
	kPa	10 <sup>3</sup>	1	10 <sup>-2</sup>	10	101.97	9.8692 10 <sup>-3</sup>	7.5	0.145	4.01	0.295
	bar	10 <sup>5</sup>	10 <sup>2</sup>	1	10 <sup>3</sup>	10197	0.98692	750	14.5	401.46	29.53
	mbar	10 <sup>2</sup>	10 <sup>-1</sup>	10 <sup>-3</sup>	1	10.197	9.8692 10 <sup>-4</sup>	0.75	1.45 10 <sup>-2</sup>	0.401	2.95 10 <sup>-2</sup>
	mmH2O	9.806	9.8067 10 <sup>-3</sup>	9.8067 10 <sup>-5</sup>	9.8067 10 <sup>-2</sup>	1	9.6784 10 <sup>-5</sup>	7.3556 10 <sup>-2</sup>	1.4223 10 <sup>3</sup>	3.937 10 <sup>-2</sup>	2.895 10 <sup>-3</sup>
	atm	1.013 10 <sup>5</sup>	101.33	1.0133	1013.3	10332	1	760	14.695	406.78	29.921
	Torr	133.32	0.13332	1.3332 10 <sup>-3</sup>	1.3332	13.595	1.3158 10 <sup>-3</sup>	1	1.9337 10 <sup>-2</sup>	0.535	3.937 10 <sup>-2</sup>
	psi	6897.8	6.8948	6.8948 10 <sup>-2</sup>	68.948	703.07	6.8045 10 <sup>-2</sup>	51.71	1	27.68	2.036
	inH2O	249.09	0.2491	2.4909 10 <sup>-3</sup>	2.4909	25.400	2.4583 10 <sup>-3</sup>	1.8683	3.61 10 <sup>-2</sup>	1	7.35 10 <sup>-2</sup>
	inHg	3386.4	3.3864	3.3864 10 <sup>-2</sup>	33.864	345.32	3.3421 10 <sup>-2</sup>	25.4	0.491	13.595	1





## Index

	<b>2</b>			
24 V DC indicator light		21	LCD 4 line display	23
	<b>A</b>		Leak mode	26
Additional functions		42	Leak/Flow calibrator	69
Adjust regulator pressure		58	Lighting the screen	54
ATR cycle		44		<b>M</b>
ATR error		71	Maximum fill	30
ATR fault		71	Measurement cycle	8
ATR learning		62	Minimum fill	30
Automatic connectors		70		<b>N</b>
	<b>B</b>		Navigation keys	22
Blockage mode		27	Needle valves	69
	<b>C</b>		Negative leak indicator	21
C540 / F580		50	Negative threshold	50
Calibration leaks		68		<b>O</b>
Characteristics		6	Operator mode	27
Choose a cycle end		45		<b>P</b>
Conversion table		78	Parameter settings	28
Create a new program		25	Part OK indicator	21
Cycle end		45	Power supply	67
Cycle keys		22	Pressure inferior to min threshold	71
	<b>D</b>		Pressure over max threshold	71
Definition of the <b>ATEQ F405</b>		5	Pressure too high	71
Delete a program		34	Pressure units	30
Desensitized Mode		27	Print frame	51
Detailed display of the test results		65	Print parameters	51
Determine the fill time		29	Print the results	50
Determine the stabilization time		29	Printer	17, 50
Direct measurement		7	Printing the results	65
Dump level		55	Program choice	35
Dump time		30	Programmable input	14
Duplicate a program		32		<b>R</b>
	<b>E</b>		Recoverable reject level	50
Encombrements		76	Recoverable thresholds	50
Export the results to Microsoft Excel		52	Regulator adjustment	36
Extended menus		42	Reject units	31
	<b>F</b>		Remote control	12, 13
Fail bad indicator		21	Reset the results memory	65
Filtration kit		70	RS232	17
Frame formats		51		<b>S</b>
Functions		31	Sequence several test cycles	43
Functions menu		40	Special cycles	36
	<b>I</b>		Stand by	65
I/O Configuration		56	Stop the measurement	36
Indirect measurement		7	Symbols	9
Infinite fill		59		<b>T</b>
	<b>K</b>		Test error	71
Key access position		23	Test in calibrated Pa/s or Pa	60
Key locked position		23	Test reject	31
	<b>L</b>		Test time	30
Language		65	Test types	26

**W**  
Wait times A and B .....28

Work in calibrated Pa/s or Pa .....61



