

ATEQ G520
Version 1.03



(Photo non contractual)

www.ateq.com

REVISIONS OF THE ATEQ G520 USER MANUAL

<u>Edition/Revision</u>	<u>Reference</u>	<u>Date</u> week/year	<u>Chapters updated</u>
First edition	UM-19700A-U	28/2002	-
Second edition	UM-19700B-U	04/2004	Evolution of the program from version 1.01 to 1.02 (temperature correction).
Third edition	UM-19700C-U	06/2005	Replace LEAK TEST text by FLOW TEST text on all displays, chapter 3. Add test output on chapter 1.
Fourth edition	UM-19700D-U	24/2005	Up dating the measurements characteristics in the preamble. Program evolution to the 1.03 version. Differential sensor coefficient adjustable in the line production. Functioning identical to the 1.02 version. Add cut and external dump valves options in the chapter 5.
Fifth edition	UM-19700E-U	05/2006	Up dating the measurements characteristics in the preamble.

Recommendations for leak testing instruments

Precautions for the test environment

- Keep the test area as clean as possible.

Precautions for the operators

- **ATEQ** recommends that the operators using the instruments should have a suitable qualification and training with respect to the work bench requirements.

General precautions

- Read the user manual before using the instrument,
- all electrical connections to the instrument must be equipped with a safety system (fuse, circuit breaker...) appropriate to its needs and complying with the standards,
- to avoid electromagnetic interference, the cable connections to the instrument should be less than two meters in length,
- it is essential that the electrical main is earthed,
- disconnect the electrical connections to the equipment before maintenance,
- cut the air supply for any kinds of operation on the pneumatic assembly,
- do not open the instrument when it is powered up,
- avoid water spillage near of the instrument,
- **ATEQ** is at your disposal for any further information concerning the use of the instrument under maximum safety conditions.



We would like to bring to your attention that ATEQ will not be held responsible for any accident connected to the improper use of the instrument, to the work bench or to the lack of compliance with safety rules.

ATEQ Company is free from any responsibility for any adjustment of its instrument which would not have been done by its own technicians.

ATEQ, THE ASSURANCE OF A COMPETENT AFTER SALES SERVICE

■ THE ATEQ AFTER SALES SERVICE IS :

- a team of qualified technicians,
- a permanent telephone assistance,
- agencies close to you for faster reaction,
- a stock of spare parts available immediately,
- a car fleet for rapid intervention,
- a commitment to quality ...

■ THE OVERHAUL

ATEQ carries out the overhaul of your instruments at interesting prices.

The overhaul corresponds to the maintenance of the instrument (checking, cleaning, replacing of used parts) as part of preventive maintenance.

Preventive maintenance is the best way to guarantee reliability and efficiency. It allows the maintenance of a group of instruments in good operational order and prevent eventual break-downs.

■ MAINTENANCE KITS

The ATEQ After Sales Service proposes, two kits destined for the preventive maintenance of the pneumatic circuits of instruments.

■ CALIBRATION

This may be carried out on site or in our offices.

ATEQ is attached to the COFRAC and delivers a certificate following a calibration.

■ TRAINING COURSES

In the framework of partnership with our customers, ATEQ offers two types of training in order to optimise the usage and knowledge of our instruments. They are aimed at different levels of technician:

- method / control training,
- maintenance / upkeep training.

■ A TARGETED TECHNICAL DOCUMENTATION

A number of technical documents are at your disposal to allow you to intervene rapidly in the event minor breakdowns:

- problem sheets describing and offering solutions to the main pneumatic and electronic problems,
- several maintenance manuals.

■ A QUALITY GUARANTEE

The instruments are guaranteed for parts and labour in our offices:

- 2 years for leak detection equipment,
- 1 year for electrical tests to norms instruments,
- 1 year for the accessories.

Our After Sales Service is capable of rapidly answering all your needs and queries.

**ATEQ recommends
to made realise by its departments
a revision and a calibration of the instruments
every year**

PREFACE

Dear Customer,

You have just purchased an **ATEQ** instrument, we thank you for the trust you have placed on our brand. This instrument has been designed to ensure a long and unparalleled life expectancy, and we are convinced that it will give you complete satisfaction during many long years of operation.

In order to maximise the life expectancy and reliability of your **ATEQ** instrument, we recommend that you install this instrument on a secured workbench and advise you to consult this manual in order to familiarise yourself with the functions and capabilities of the instrument.

Our **ATEQ** After Sales Service centre can give you recommendations based on your specific operation requirements.

ATEQ

TABLE OF CONTENTS

Preamble	DEFINITION AND PRINCIPLES OF THE G520
1. DEFINITION	5
2. CHARACTERISTICS MEASUREMENT	6
2.1. Flow measurement.....	6
2.2. Pressure measurement.....	6
2.3. Mechanical pressure regulation	6
3. OPERATIONAL CHARACTERISTICS.....	7
4. PRESENTATION OF THE SYMBOLS	8
Chapter 1	INSTALLATION OF THE INSTRUMENT
1. APPEARANCE OF THE ATEQ G520	11
1.1. Layout of connectors on the G520 rear panel.....	12
1.2. Connector details	12
1.2.1. Electrical connectors	12
1.2.2. Pneumatic connectors	17
1.2.3. Pneumatic test output.....	17
Chapter 2	USER INTERFACES
1. ATEQ G520 FRONT PANEL APPEARANCE.....	19
2. APPEARANCE OF THE KEYBOARD	20
2.1. Navigation keys.....	20
2.2. Cycle keys	20
3. LOCKABLE SWITCH	21
4. INFRA-RED INTERFACE	21
5. 4 LINE LCD DISPLAY	21
6. FUNCTIONS OF THE INDICATOR LIGHTS	22
Chapter 3	INSTALLATION AND SETTINGS
1. POWERING UP THE ATEQ G520	23
2. CREATION OF A TEST PROGRAM.....	23
2.1. Choice of the program number	24
2.2. Test type selection	24
2.2.1. Flow test	24
2.2.2. Operator mode test.....	24
2.3. Parameter settings	25
2.3.1. Coupling time.....	26
2.3.2. Fill time	26
2.3.3. Stabilization time	27
2.3.4. Test time.....	27
2.3.5. Pressure units.....	27
2.3.6. Set pressure	28
2.3.7. Maximum fill.....	28
2.3.8. Minimum fill.....	28
2.3.9. Test pressure adjustment	28
2.3.10. Reject unit.....	28
2.3.11. Volume	29
2.3.12. Test reject.....	29
2.3.13. Functions	29
3. DUPLICATION OF A TEST PROGRAM	30
4. DELETING A PROGRAM OR A PROGRAM NAME	31
5. CHOICE OF THE PROGRAM TO BE RUN	32
6. STARTING A MEASUREMENT CYCLE.....	32
7. STOPPING A CYCLE	32

Chapter 4**FUNCTIONS OF THE INSTRUMENT**

1. MENU STRUCTURE	33
1.1. Main menu.....	33
1.2. "FUNCTIONS" menu when activated.....	37
2. CONFIGURATION MENU	39
2.1. Extended menus	39
2.1.1. Activation of the additional functions	39
2.1.2. Setting the additional functions.....	40
2.1.3. List of additional functions	40
2.2. Automatic save.....	52
2.3. Piezo auto zero	52
2.4. Bar Graph.....	53
2.5. Hour.....	53
2.6. RS232	53
2.6.1. C540/580	53
2.6.2. Printer	53
2.6.3. Modbus.....	57
2.7. RS485	58
2.7.1. C540/580.....	58
2.7.2. Modbus.....	58
2.8. Security	58
2.9. Lighting the screen	58
2.10. External dump option	59
2.11. Shut off (option).....	60
2.12. Negative flow alarm.....	61
2.13. I/O configuration	61
3. SPECIAL CYCLES MENU	62
3.1. Special cycles available	62
3.2. Volume calculation	63
3.3. Infinite fill	64
3.4. Piezo auto zero	65
3.5. Print.....	66
3.6. Atmospheric conditions	66
4. SERVICE MENU	67
4.1. Parameters service	67
4.2. Servicing of the sensors.....	68
5. RESULTS MENU	69
6. LANGUAGE MENU	69
7. STAND BY MENU	69
7.1. Standby using the menu	70

Chapter 5**ACCESSORIES**

1. ACCESSORIES SUPPLIED WITH THE INSTRUMENT	71
1.1. Power supply.....	71
2. OPTIONAL ACCESSORIES	72
2.1. Calibrated leak	72
2.2. Needle valve and Leak/Flow Calibrator (CDF)	73
2.2.1. Needle valve.....	73
2.2.2. CDF (Leak/flow Calibrator)	73
2.3. Automatic connectors with expandable joints	74
2.3.1. Operation.....	74
2.3.2. Standard dimensions	74
2.4. Filtration kit.....	74
2.5. Simple remote control	75
2.5.1. Casing reset/start	75
2.5.2. S5 four-function remote control	75
2.6. External shut off valve option	76
2.7. External dump valve and shut off function	76

Chapter 6	ERROR MESSAGES
ERROR MESSAGES	77
Chapter 7	OPERATIONAL PROBLEMS
1. PHENOMENON NOTED.....	79
1.1. Condition of the machine's seals	79
1.2. Damaged instrument seals	79
1.3. Bumper pad.....	79
1.4. Pneumatic air supply too low	79
1.5. Pneumatic Link.....	79
1.6. Environment	80
1.7. Calibration	80
1.8. Concerns about reliability of the instrument's circuits	80
Appendices	ATEQ G520
1. TECHNICAL CHARACTERISTICS OF THE G520	81
2. MECHANICAL DEFINITION DRAWINGS OF G520.....	82
3. CONVERSION TABLE	83
4. PARAMETERS STORED	84
5. VALVES CODES USED IN YOUR APPLICATION	85
6. USER NOTES	86
Index	87

Preamble

DEFINITION AND PRINCIPLES OF THE G520

1. DEFINITION

The **ATEQ G520** is the latest air/air leak detector operating on a continuous basis (automatic test start).

The instrument has been designed to test low pressure components and assemblies (less than 500 mbar) and more particularly gas applications in compliance with European standards, but it can also work with high pressure.

The use of continuous testing may allow the localisation and repair of leaks.

The instrument may also operate in "controlled" mode, a mode which is advantageous for certain applications, with pre-fill or rapid fill or on automatic workbenches.

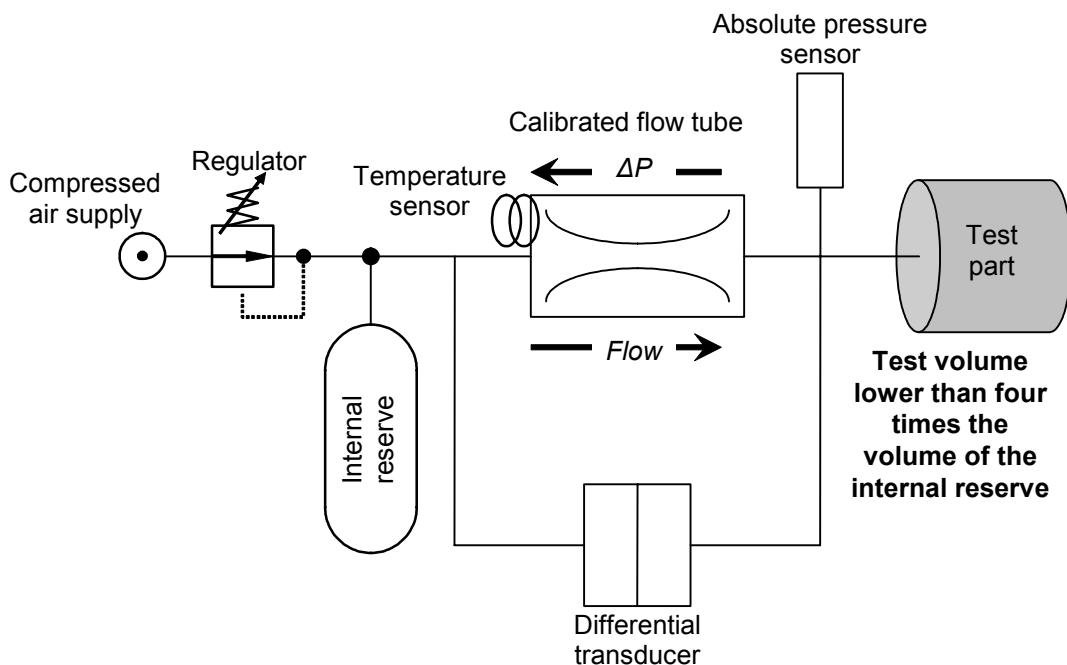

The **ATEQ G520** includes:

a pneumatic assembly allowing:

- the pressurisation of the test part and the reserve through the use of a regulator,
- the measurement of the leak flow image with a differential transducer placed on the end of a calibrated flow tube,
- the monitoring of the test pressure with a piezo sensor acting as a pressure controller,
- the temperature measurement of the calibrated flow tube to correct the measured flow,

a programmable electronic board allowing:

- the saving of all the cycle adjustments,
- the calculation, display and transmission of the test results.

2. CHARACTERISTICS MEASUREMENT

2.1. FLOW MEASUREMENT

RANGE	ACCURACY	Maximum RESOLUTION
100 cm ³ .atm/h	+/- (3,5% of the flow + 0,5 ml/h)	0,1 cm ³ .atm/h
1000 cm ³ .atm/h	+/- (3,5% of the flow + 5 ml/h)	1 cm ³ .atm/h

2.2. PRESSURE MEASUREMENT

The characteristics are common for all the 5th series instruments.

RANGE	ACCURACY	Maximum RESOLUTION
F. S. = 7,5 kPa* (F. S. = 75 mbar*)	+/- (1,5% of the pressure + 0,2 hPa)	0,1 % F. S.
F. S. < 30 kPa (F. S. < 0,3 bar)	+/- (1,5% of the pressure + 1 hPa)	0,1 % F. S.
30 ≤ F. S. ≤ 100 kPa (0,3 ≤ F. S. ≤ 1 bar)	+/- (1,5% of the pressure + 3 hPa)	0,1 % F. S.
100 ≤ F. S. ≤ 1000 kPa (1 < F. S. ≤ 10 bar)	+/- (1,5% of the pressure + 7.5 hPa)	0,1 % F. S.

* Specific (relative)

G 5 th series pressure range	
5 – 50 kPa	50 – 400 kPa

2.3. MECHANICAL PRESSURE REGULATION

5 kPa to 50 kPa / 50 kPa to 400 kPa

3. OPERATIONAL CHARACTERISTICS



The **ATEQ G520** carries out a pressure measurement on the ends of calibrated flow tubes connecting the test part and the internal instrument reference part (reserve) which have been previously equalised at the same pressure.



The measurement is displayed in ml/minute or in ml/hour returned to atmospheric pressure.

The flow measurement is dependant on a certain number of parameters: test pressure, the volume of the part to be tested, the volume of the reference. Additionally, it is necessary to optimise a number of adjustments (timings). We have strived towards the production of a user friendly instrument, that is why a few adjustments are not accessible to the operator. These are set in the factory depending on a customers' required specifications.

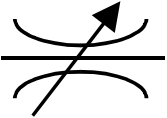
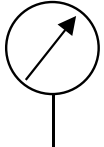
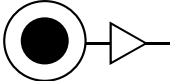
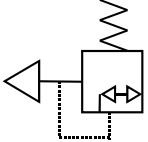
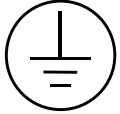
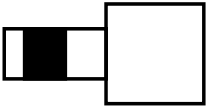
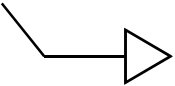
It's also possible to work in standard conditions mode.

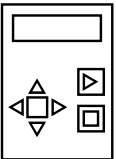
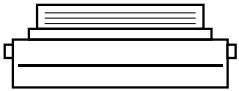
4. PRESENTATION OF THE SYMBOLS

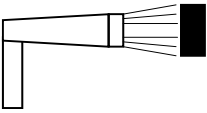
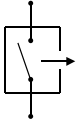
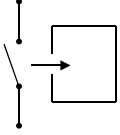
Symbol	Name	Function
	Adjust leak connector	Pneumatic connector for the plugging of a calibrated leak (ruby kind) or an adjustable leak.
	Pressure connector	Pneumatic connector for the plugging of a manometer for an external checking of the pressure.
	Pressure supply	of the air supply from the 6 bar network.
	Test circuit supply	Pneumatic connector (according to option) for the plugging of a supplementary pneumatic supply, used in case of test pressure greater than 8 bar.
	Ground connector	Connector for the electric plugging to the ground.
	Automatic connector	Pneumatic connector for the driving of an external logic or pneumatic components (pneumatic sealing connector).
	Connector	Connector for pneumatic output.
	Connector	Connector for pneumatic input.
	Warning!	Read and respect the instructions of the user manual, before plugging and using the instrument.
	Remote control	Connector for a remote control.
	Printer	Connector for printer plugging.

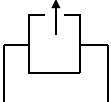
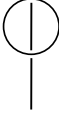
Symbol	Name	Function
	Bar code reader	Connector for bar code reader plugging.
	Output	Dry contact output.
	Input	Dry contact input.
	Infrared link	Infrared link, at this place there's the receiver and transmitter of the infrared link.
	Analogue output	Analogue output.
	Analogue input	Analogue input for the temperature sensor.

Chapter 1

INSTALLATION OF THE INSTRUMENT

1. APPEARANCE OF THE ATEQ G520

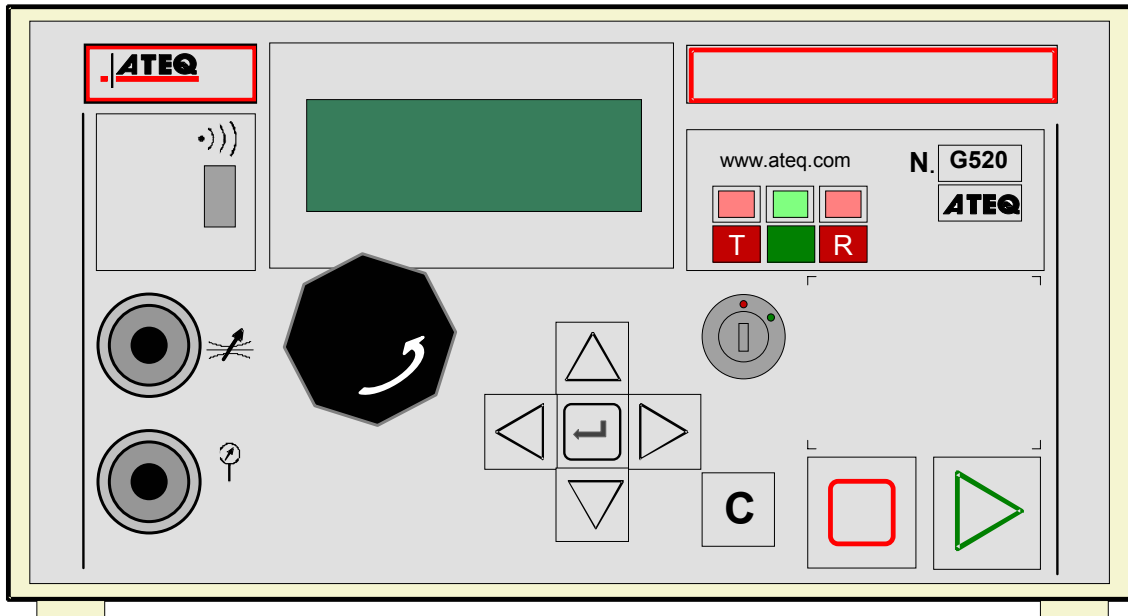

The **ATEQ G520** is supplied in a moulded, painted sheet metal case and rests on rubber feet. The upper cover is attached to the main body by two screws.

The size of the casing has been reduced to facilitate the insertion of the instrument in the working environment.

A 24 V DC power supply unit is supplied with the instrument.

1.1. LAYOUT OF CONNECTORS ON THE G520 REAR PANEL

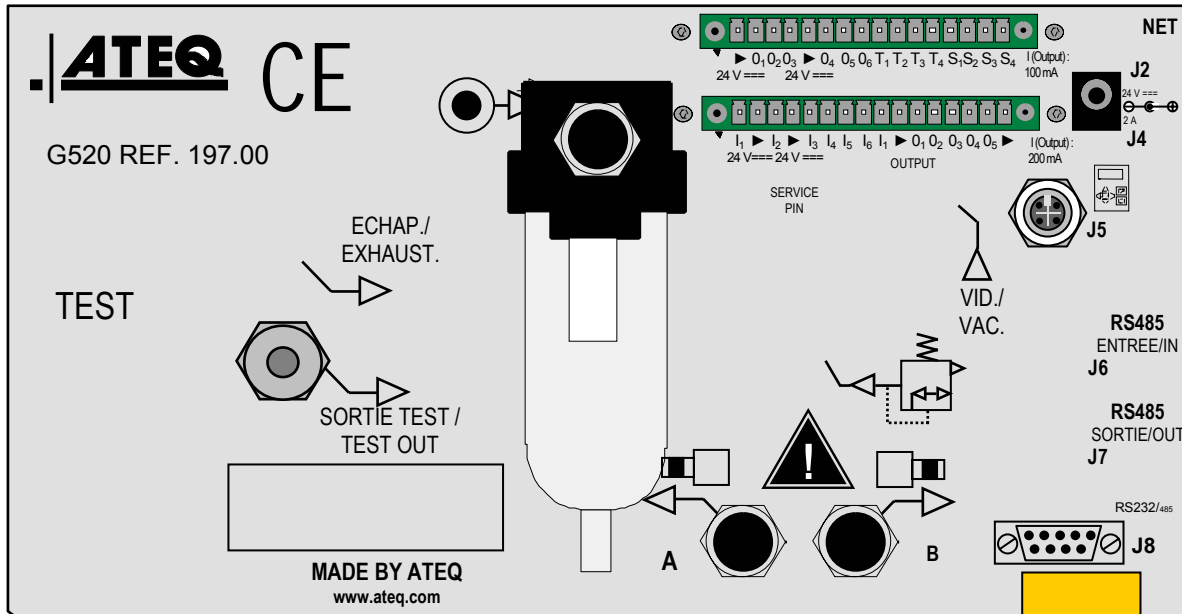

1.2. CONNECTOR DETAILS

1.2.1. Electrical connectors

The **ATEQ G520** operates on a voltage of 24V DC either:

- ✓ Using the external power supply supplied with the instrument,
- ✓ Or via the networking cable when the instrument is a slave.

1.2.1. 1) J1 Connector (Output codes / analogue outputs / temperature sensors)

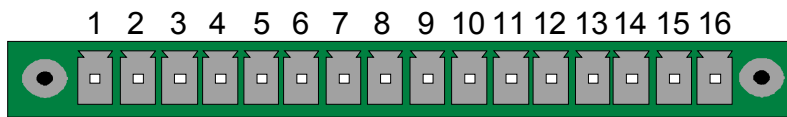

	COMMON (Outputs 1,2,3)	OUTPUT CODES 24V DC 100mA Max Outputs
PIN 2	Output n°1	
PIN 3	Output n°2	
PIN 4	Output n°3	
PIN 5	COMMON (Outputs 4,5,6)	
PIN 6	Output n°4	
PIN 7	Output n°5	TEMPERATURE SENSORS
PIN 8	Output n°6	
PIN 9	12V Sensor power supply	
PIN 10	0V Sensor power supply	ANALOGUE OUTPUTS
PIN 11	Sensor n°1 Input	
PIN 12	Sensor n°2 Input	
PIN 13	Analogue output n°1	
PIN 14	COMMON (Analogue output 1)	
PIN 15	Analogue output n°2	
PIN 16	COMMON (Analogue output 2)	

The analogue outputs are the rough signals: 4 – 20 mA or 0 – 10 V depending on the chosen option.

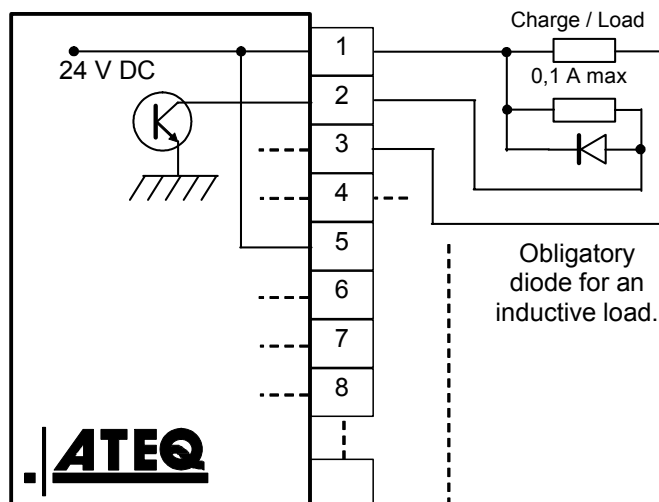

1.2.1. 2) J3 Connector (I/O Inputs/Outputs)

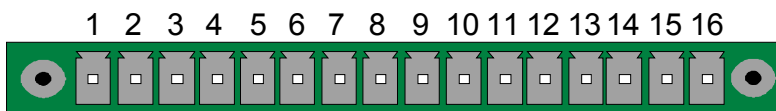

PIN 1	RESET (input 1)	INPUTS (Activation by 24 V DC)
PIN 2	Common (+ 24 V)	
PIN 3	START Input (input 2)	
PIN 4	Common (+ 24 V)	
PIN 5	Input 3 (program selection)	
PIN 6	Input 4 (program selection)	
PIN 7	Input 5 (program selection)	
PIN 8	Input 6 (program selection)	
PIN 9	Input 7 (program entry)	
PIN 10	Floating common outputs	OUPUTS DRY CONTACTS 60V AC / DC Max 200mA Max
PIN 11	Part OK output	
PIN 12	Part BAD output	
PIN 13	Large leak output	
PIN 14	Alarm output	
PIN 15	End of cycle alarm	
PIN 16	0 V	

1.2.1. 3) Activating a program from the J3 connector inputs

To activate a program from the J3 connector inputs, pins 5 to 8 must be selected (one or more at a time). Binary weight $n + 1$.

Pin combinations for program selection

Program number	Pin 5 (Input 3)	Pin 6 (Input 4)	Pin 7 (Input 5)	Pin 8 (Input 6)
1	0	0	0	0
2	1	0	0	0
3	0	1	0	0
4	1	1	0	0
5	0	0	1	0
6	1	0	1	0
7	0	1	1	0
8	1	1	1	0
9	0	0	0	1
10	1	0	0	1
11	0	1	0	1
12	1	1	0	1
13	0	0	1	1
14	1	0	1	1
15	0	1	1	1
16	1	1	1	1

1.2.1. 4) J3 Connector (I/O Inputs/Outputs)programmable input

Input 7 can be parameterised in the **CONFIGURATION/ INPUT OUPUT** menu.

- ✓ Program selection
- ✓ Auto zero reset request,
- ✓ Infinite fill request.

Some possibilities only appear if the function is used.

1.2.1. 5) J3 Connector (I/O Inputs/Outputs) drawing

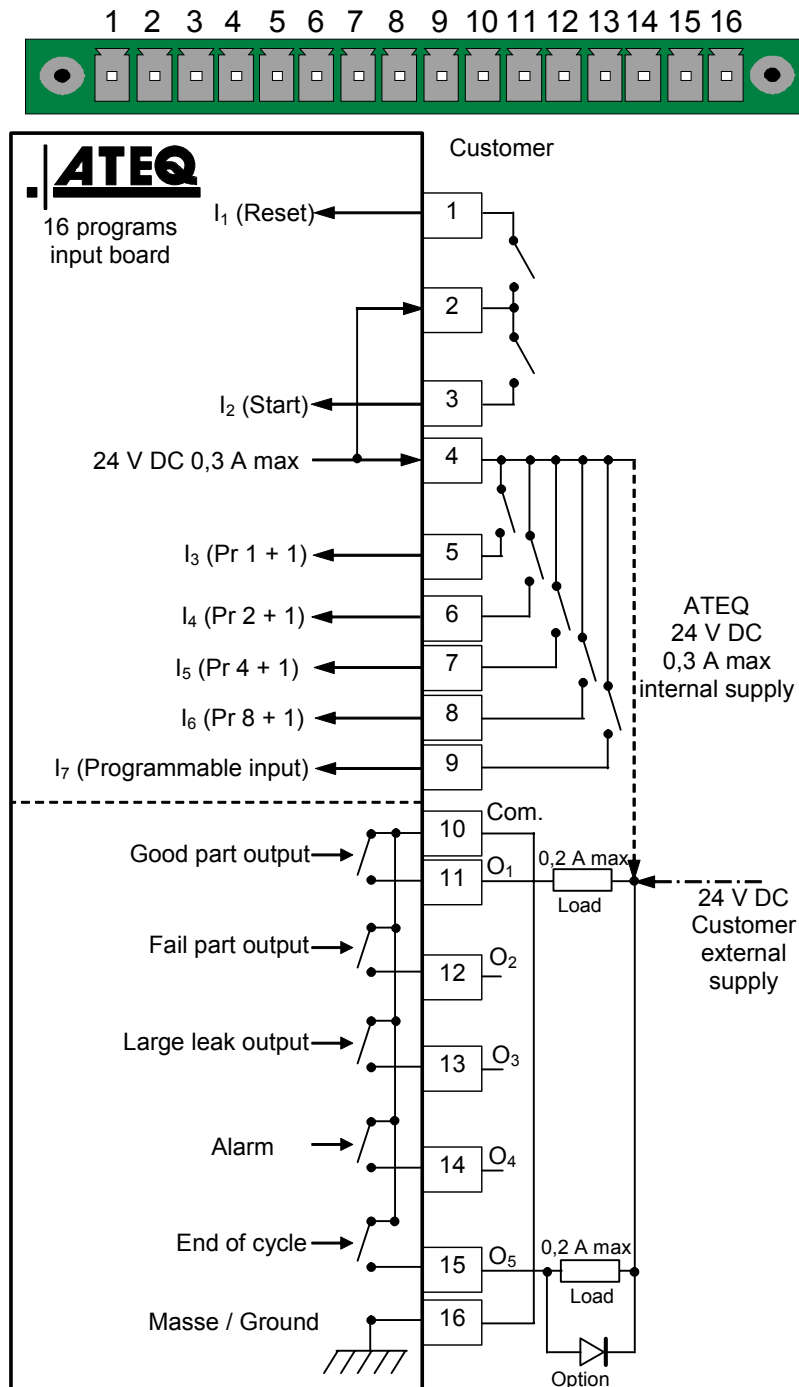

Note: The 24V power supply must be provided by the internal power supply of the ATEQ instrument (0,3A maximum) **OR** through an external power supply provided by the customer.

1.2.1. 6) J4 Connector



Used for connection of the power supply.
The instrument can be supplied from the J3 connector relay board on the 24 V DC pin.

1.2.1. 7) J5 Connector (remote)

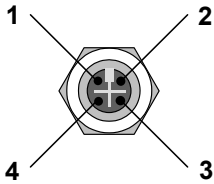

Used for connection of an intelligent remote control.
(Lumberg female connector).

PIN 1	Network
PIN 2	+ 24V Power supply
PIN 3	Network
PIN 4	0V

1.2.1. 8) J8 Connector (RS232)

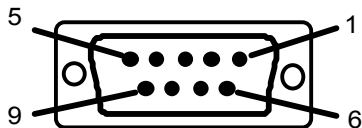

Used for connection of a printer, a bar-code reader, a PC or a memory module.

PIN 1	Not used
PIN 2	RXD Data reception
PIN 3	TXD Data emission
PIN 4	Not used
PIN 5	Earth
PIN 6	Not used
PIN 7	RTS request to send
PIN 8	CTS clear to send
PIN 9	Not used

1.2.1. 9) Examples of RS232 cables

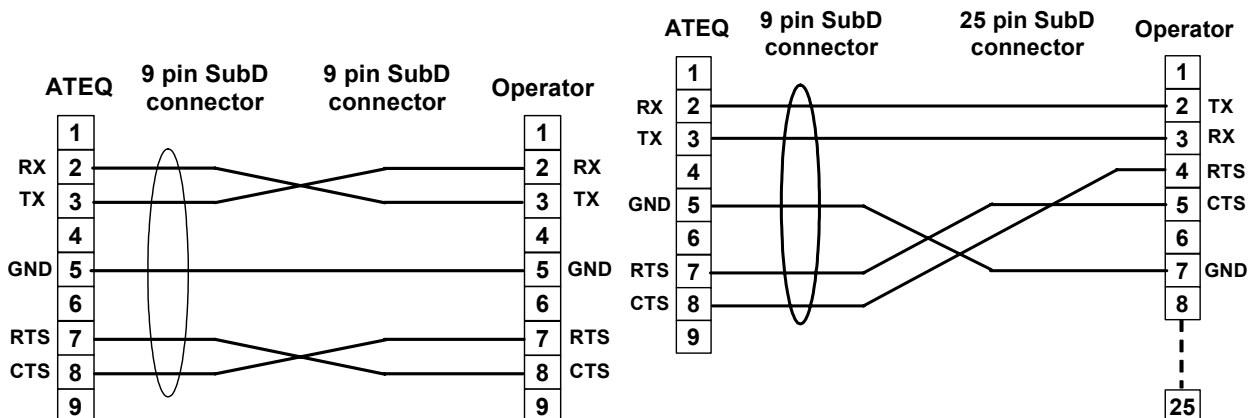

1.2.2. Pneumatic connectors

Pneumatic connectors are rear panel of the **G520** instrument.

These pneumatic outputs can carry out the following functions, depending on the configuration demanded at purchase.

Output "automatic connector A"	Output "automatic connector"
Automatic connector A	Automatic connector B
Automatic connector A	Stamping (output 1 code used)
Automatic connector A	External dump (output 2 code used)
Stamping (output 1 code used)	Dump (output 2 code used)
Automatic connector A	Shut off valve (output 2 code used)
Stamping (output 1 code used)	Shut off valve (output 2 code used)

1.2.2. 1) Automatic connector A



Used for connection of an automatic pneumatic connector.

1.2.2. 2) Automatic connector B



Used for connection of a second automatic pneumatic connector.

1.2.3. Pneumatic test output

This output allows to connect the part to be tested.

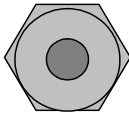

T : Test output.

1.2.3. 1) Pneumatic supply

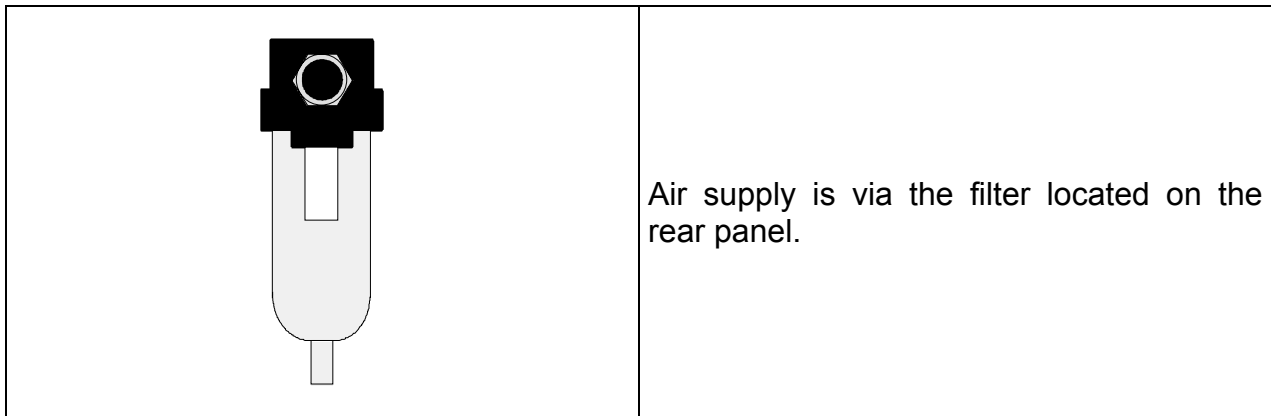

It is essential that the air supplied is clean and dry. Even though there is a filter, supplied with the instrument, the presence of dust, oil or impurities may cause malfunction.

When the instrument is working in vacuum conditions, impurities must be prevented from being drawn into its interior. For this purpose we strongly recommend that a suitable airtight filter is installed between the test part and the instrument. This filter can be supplied by **ATEQ**.

The presence of impurities, oil or humidity in the air may cause deterioration which will not be covered by the guarantee.

In accordance with ISO standard 8573-1 concerning classes of compressed air for measurement instruments in an industrial environment :

ATEQ recommends :

- | | | |
|--------------------------------|---------|---|
| • Grain size and concentration | CLASS 1 | (0.1 μm and 0.1 mg/m^3) |
| • Dew point under pressure | CLASS 2 | (- 40° dew) |
| • Maximum concentration of oil | CLASS 1 | (0.01 mg/m^3) |

ATEQ recommends the installation :

- of an air dryer to provide dry air at less than - 40° dew point,
- of a 25 micron and 1/100 micron double filter.

Optimisation of operation :

The supply pressure must always be between 4 and 8 bar to ensure that the pneumatic distributors operate with optimum efficiency.

When a mechanical regulator is used, the supply pressure must be a minimum of 100 kPa (1 bar) greater than test pressure with a minimum of 400 kPa (4 bar).

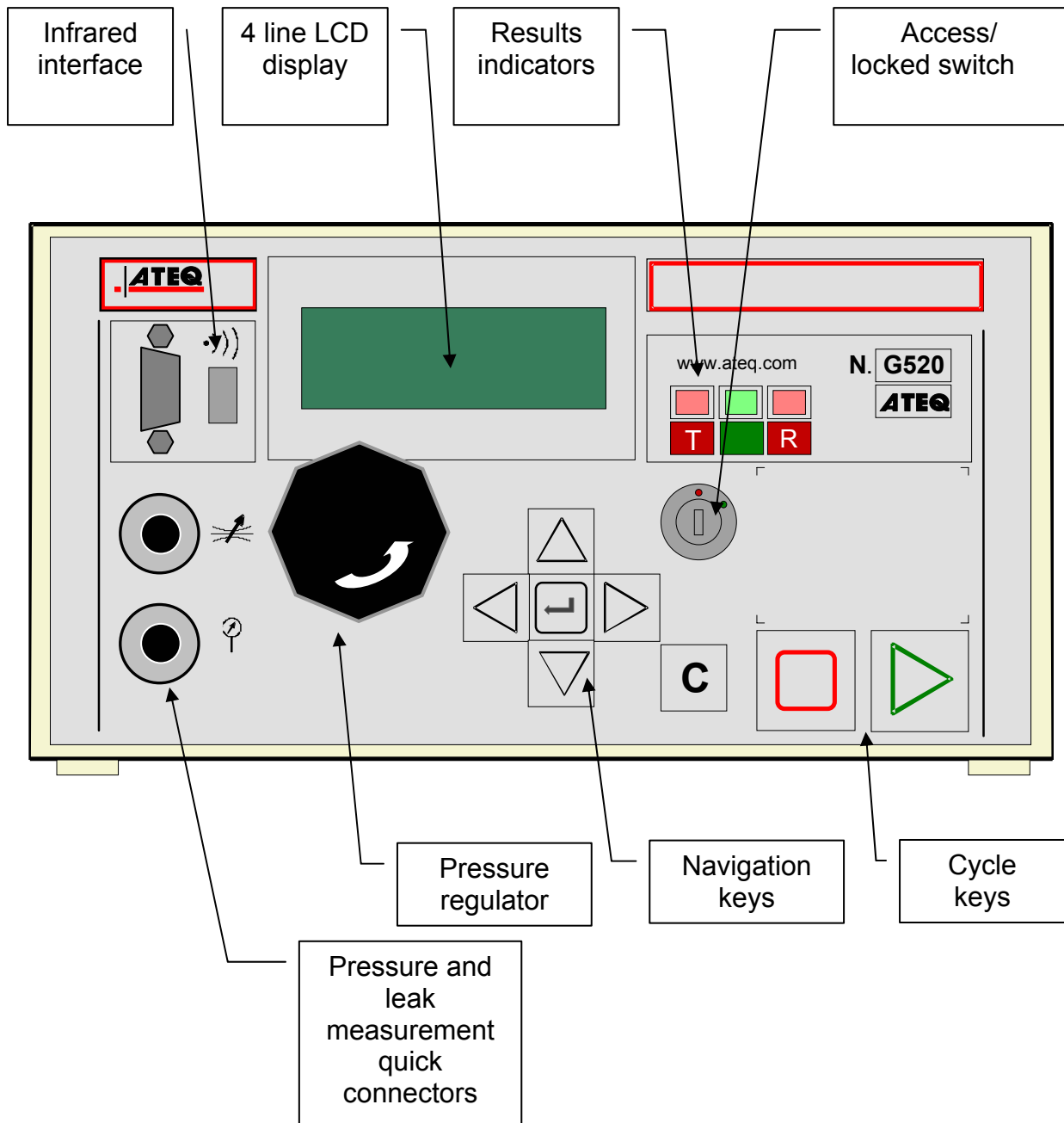

Chapter 2 USER INTERFACES

1. ATEQ G520 FRONT PANEL APPEARANCE

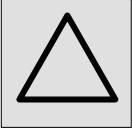
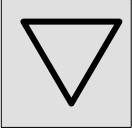
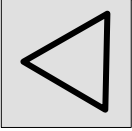
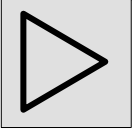

2. APPEARANCE OF THE KEYBOARD

2.1. NAVIGATION KEYS

KEY	FUNCTION
	Scroll up or increase numerical values
	Scroll down or decrease numerical values
	Not used
	Not used
	ENTER key Opening a menu Entering a parameter Confirmation of a parameter
	« C » for CANCEL Return to the previous menu or function Escape without modifying a parameter

2.2. CYCLE KEYS

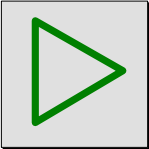
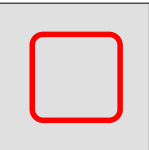
KEY	FUNCTION
	START key Starts a measurement cycle
	RESET key Stops a cycle in progress

3. LOCKABLE SWITCH

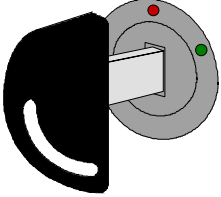
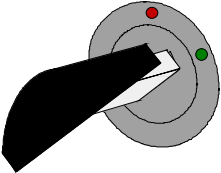
POSITION	FUNCTION
	<p>LOCKED position. Access to adjustable parameters not possible.</p>
	<p>ACCESS position. Adjustable parameters may be accessed.</p>

Note: whatever position the key is in (**LOCKED** or **ACCESS**), test cycles can be started and stopped.

4. INFRA-RED INTERFACE

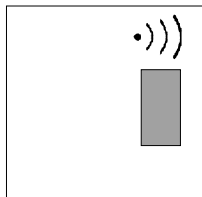

Not used.

5. 4 LINE LCD DISPLAY

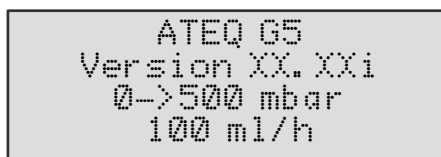



Used to display measurements and adjustable parameters. In the example opposite, XX.XXi represents the program version for the instrument.

6. FUNCTIONS OF THE INDICATOR LIGHTS

The  symbol represents an indicator which is lit.

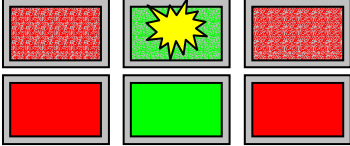
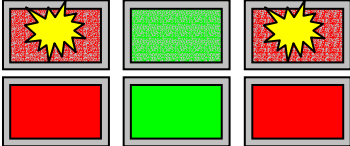
The  symbol represents an indicator which is flashing.

<p>Test part OK indicator</p>	
<p>Large leak mode or fill in progress indicator (automatic start mode).</p>	
<p>Pressure default or alarm indicator</p>	
<p>Part BAD indicator</p>	
<p>Intermittent flashing stand-by or measurement between thresholds 1 and 2 of negative flow. Refer to chapter 4 paragraph 2.12. "negative flow alarm"</p>	

Chapter 3

INSTALLATION AND SETTINGS



1. POWERING UP THE ATEQ G520

Supply the apparatus with 24 V DC. When powered up the instrument:		
- displays version and the full scale of the sensors...		<pre>ATEQ G5 Version XX.XXi 0-> 500 mbar 100 cm3/h</pre>
Carries out a RESET		<pre>CYCLE/Pr : 001 PRESS = 400.0 mbar 0-> 500 mbar RESET</pre>
...then displays the main menu.		<pre>CYCLE/Pr : 001 PRESS = 400.0 mbar READY</pre>

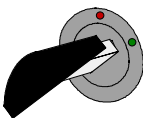
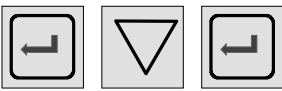
2. CREATION OF A TEST PROGRAM



To modify the parameters, turn the key to the ACCESS position.		<pre>RUN/Pr: 001 PRESS = 0.000 bar READY</pre>
To access the main menu, press ENTER . In the main menu, place the cursor in front of the PARAMETERS menu. Confirm with the ENTER key.		<pre>MAIN MENU RUN PROG. : --- PARAMETERS SPE CYCLE : Disabled</pre>
The PARAMETERS menu is used to manage test programs. ☞ If the various programs to be created have different parameters, they must be created one by one. ☞ If the programs have identical parameters, a base program can be created and then the Copy-Paste function can be used to duplicate the program as many times as is necessary.		<pre>PARAMETERS Copy-Paste Pr : 001 ----- Pr : 002 -----</pre>

2.1. CHOICE OF THE PROGRAM NUMBER

<p>Position the cursor in front of the chosen program number and confirm with the ENTER key.</p>	 	 <pre> PARAMETERS Copy-Paste Pr : 001 ----- Pr : 002 ----- </pre>
---	---	---

2.2. TEST TYPE SELECTION

Two test types are available.

<p>The PARAMETERS menu gives access to two possible types of test : flow test (FLOW TEST) and operator test (OPERATOR); see the following paragraph for explanations. Put the cursor in front of the required test type and confirm with the ENTER key.</p>	 	 <pre> PARAM/TYPE FLOW TEST OPERATOR </pre>
---	---	---

2.2.1. Flow test

The flow test allows the testing of a part for leaks by measuring a flow which is applied to it. In the event of a part having no leaks, there will be no flow, or one inferior to the reject level set.

2.2.2. Operator mode test







This type of test means that the operator can carry out operations on the part whilst under test, then to confirm these operation using a "START"  key if the operator

test is good, or "RESET"  key if the test is fail.

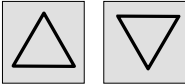
2.3. PARAMETER SETTINGS

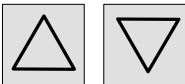
Once the test type is chosen, the test cycle parameters must be set.
The procedure to follow for setting the test parameters is identical in each case.

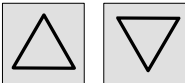
Example : Coupling time A.

<p>First, position the cursor in front of the chosen parameter using the navigation keys (here, Coupl. A).</p>		<pre>PARAM/pr001 TYPE : FLOW TEST COUPL. A: 00.00 s FILL : 00.00 s</pre>
<p>Then, confirm with the ENTER key. The cursor will move to the right of the display.</p>		<pre>PARAM/pr001 TYPE : FLOW TEST COUPL. A: 00.00 s FILL : 00.00 s</pre>
<p>Modify the value using the navigation keys.</p>		<pre>PARAM/pr001 TYPE : FLOW TEST COUPL. A: 00.03 s FILL : 00.00 s</pre>
<p>Once the value is modified, confirm with the ENTER key.</p>		<pre>PARAM/pr001 TYPE : FLOW TEST COUPL. A: 03.00 s FILL : 00.00 s</pre>
<p>To move on to the next parameter, use the navigation keys.</p>		<pre>PARAM/pr001 TYPE : FLOW TEST COUPL. A: 03.00 s FILL : 00.00 s</pre>
<p>To exit from the menu, use the CANCEL key.</p>		<pre>PARAMETERS Cut-Paste Pr: 001 FLOW TEST Pr: 002 FLOW TEST</pre>

2.3.1. Coupling time

Coupling times A and B are start of cycle parameters.

If there is no automatic connector, Coupling time A is part of the cycle.

If an instrument is fitted with an automatic connector, Coupling time A delays the pressurisation of the test part by allowing the activation of a first cycle connector at the test start. Coupling time B allows the activation of a second automatic connector. These Coupling times ensure better stabilization of the seals placed on the test part.

☞ Set this parameter using the method described in § 2.3.

2.3.2. Fill time

This is the time allowed for the pressurisation of the part to be tested. It must not be too long (waste of time) or too short (the pressure in the component is at risk of not being sufficient due to drops in pressure caused by temperature changes).

To determine the appropriate fill time, it is necessary to set the **Fill Time** in order to make it too long, then to shorten it until a drop in pressure occurs due to thermal effects.

- ✓ Carry out a cycle. When the instrument switches to the stabilization period, the pressure must remain stable.
- ✓ A pressure drop (since there will be no fall in pressure due to thermal effects) signifies the presence of a large leak; check the test part and the pneumatic assembly components, then start again.
- ✓ If the pressure remains stable, the part does not contain a large leak and the fill time is too long. Shorten it progressively by carrying out cycles until a drop in pressure is noticeable.
- ✓ As soon as a fall in pressure due to thermal effects appears, the fill time has become too short. Increase it slightly.

☞ Set this parameter using the method described in § 2.3.

2.3.3. Stabilization time

This time is used to stabilise the pressure in the test circuit.

It is possible that a change in pressure occurs due to thermal exchanges between the components. If the instrument takes a measurement too early, the instrument will indicate the presence of a large leak.

- ✓ To determine the correct stabilization time, it is necessary to set a long time so that the reading at the end of the test time is equal to zero.
- ✓ Set the stabilization time to four times the length of the fill time.
- ✓ Carry out a cycle. When the instrument switches to the test period, the flow must remain at zero.
- ✓ If there is a drop in pressure, there is a small leak present. Check the test part and the pneumatic connections, then start again.
- ✓ If the flow is close to nil, the part does not contain a small leak and the stabilization time is therefore too long. Progressively shorten and carry out cycles (wait one minute between each cycle) until you see the appearance of a drop in flow. This indicates that the stabilization time has become too short. Increase it slightly.

☞ Set this parameter using the method described in § 2.3.

2.3.4. Test time

The test time depends on the reject level as the test pressure is supplied by the reserve. The greater the leak is, the faster the pressure drops.

A compromise must therefore be found between the stabilization and test times to obtain a flow measurement at a pressure as close as possible to that of the set (instruction) pressure.

NB: in "Auto Start" mode, the test time parameter is removed (infinite test).

☞ Set this parameter using the method described in § 2.3.

2.3.5. Pressure units

The different units are bar, mbar, PSI, Pa, kPa, MPa. .

☞ Set this parameter using the method described in § 2.3.

2.3.6. Set pressure

This instruction is the test pressure which must be applied to the part. This is because the flow will be constantly recalculated for this set pressure. Beyond a drop of 10 to 20 % in pressure, the error on the flow becomes significant. It is therefore important to have a real test pressure as close as possible to that of the set instruction pressure.

When setting the parameters for a new test cycle (creation of a new program) the default instruction pressure displayed is the value of the calibration pressure which was set in the factory.

☞ Set this parameter using the method described in § 2.3.

2.3.7. Maximum fill

This function is used to set a maximum limit for the fill pressure which triggers an alarm if this limit is exceeded. This threshold is automatically calculated to +20% after the validation of the instruction pressure and can be modified manually.

When test time is infinite, the maximum fill pressure monitoring remains in operation.

☞ Set this parameter using the method described in § 2.3.

2.3.8. Minimum fill

This function is used to set a minimum limit for the fill pressure which triggers an alarm if it is not reached.

This function is used to set a minimum limit for the fill pressure which triggers an alarm if this limit is not reached. This threshold is automatically calculated to -20% after the validation of the instruction pressure and can be modified manually.

When test time is infinite, the minimum fill pressure monitoring remains in operation.

☞ Set this parameter using the method described in § 2.3.

2.3.9. Test pressure adjustment

The adjustment of the pressure on the regulator can be carried out when the instrument is not in a test cycle, with a good part connected to the instrument (permanent flow).

2.3.10. Reject unit

The reject units are: ml/min, ml/h.

☞ Set this parameter using the method described in § 2.3.

2.3.11. Volume

The volume parameter is imperative for the flow measurement.

It's the total volume connected to the test output.

It's exists a special cycle "**Volume calculation**" who allows to estimate the volume if is not known (see the chapter 4 paragraph 2.1.3.15) "Volume calculation").

☞ Set this parameter using the method described in § 2.3.

2.3.12. Test reject

This function is used to set a limit level below which the part is considered to be bad.

☞ Set this parameter using the method described in § 2.3.







2.3.13. Functions

The **FUNCTION** menu gives access to additional parameters which must first be activated in the **CONFIGURATION** menu and then the **EXTENDED MENU**.

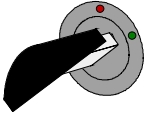
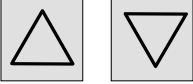
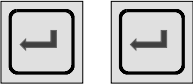
If no additional parameters are confirmed in the **EXTENDED MENUS**, the **FUNCTION** menu will be empty when selected.

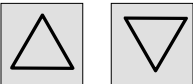

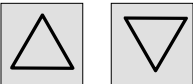

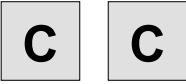

To activate these parameters, refer to chapter 4 § 2.

3. DUPLICATION OF A TEST PROGRAM

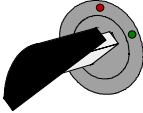
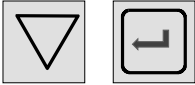



To modify the parameters, turn the key to the ACCES position.		
Starting from the main menu, position the cursor in front of the PARAMETERS function.		<pre>MAIN MENU RUN PROG.: 001 PARAMETERS SPE CYCLE : Disabled</pre>
Confirm with the ENTER key. The cursor will appear in front of the Copy-Paste function. Confirm the function again using the ENTER key.		<pre>PARAMETERS Copy-Paste Pr : 001 ENGINE Pr : 002 HEAD</pre>
Next, confirm the COPY function.		<pre>PARAM/ Copy-Paste COPY : Pr --- PASTE : Pr ---</pre>
Display the number of the program to be copied using the navigation keys. (In this case, program no.1).		<pre>PARAM/ Copy-Paste COPY : Pr 001 PASTE : Pr ---</pre>
Confirm using the ENTER key.		<pre>PARAM/ Copy-Paste COPY : Pr 001 PASTE : Pr ---</pre>
Place the cursor in front of PASTE .		<pre>PARAM/ Copy-Paste COPY : Pr 001 PASTE : Pr ---</pre>
Confirm with the ENTER key. Assign a number to this new program using the navigation keys (For example no.3).		<pre>PARAM/ Copy-Paste COPY : Pr 001 PASTE : Pr 003</pre>
Confirm with the ENTER key, The display confirms that the program has been copied.		<pre>COPY IN PROGRESS</pre>
The program no.1 parameters have now been copied into program no.3 parameters. In this example program no.3 is an exact copy of program n°1.		<pre>PARAM/ Copy-Paste COPY : Pr 001 PASTE : Pr 003</pre>

<p>Press the CANCEL key twice to return to the main menu.</p>		<pre> MAIN MENU PARAMETERS SPE CYCLE: Disabled CONFIGURATION </pre>
--	---	---

4. DELETING A PROGRAM OR A PROGRAM NAME

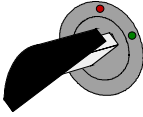
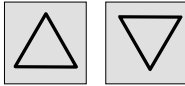
<p>To modify the parameters, turn the key to the ACCES position.</p>		
<p>Position the cursor in front of PARAMETERS function. Confirm with the ENTER key.</p>		<pre> MAIN MENU RUN PROG.: 001 PARAMETERS SPE CYCLE : Disabled </pre>
<p>Position the cursor in front of the program number or the program name to be deleted.</p>		<pre> PARAMETERS Copy-Paste Pr: 001 ENGINE Pr: 002 HEAD </pre>
<p>Confirm once to enter the program.</p>		<pre> PARAM/Pr001 TYPE : FLOW TEST WAIT A: 00.00 s WAIT B: 00.00 s </pre>
<p>Confirm a second time to gain access to the delete menu. There are two possibilities : delete the program name or delete the whole program.</p>		<pre> M/Pr001/TEST TYPE Delete name Program reset </pre>
<p>1°) Confirm a third time. The name of the program is deleted.</p>		<pre> PARAMETERS Copy-Paste Pr: 001 ----- Pr: 002 HEAD </pre>
<p>2°) Place the cursor in front of Program reset.</p>		<pre> M/Pr001/TEST TYPE Delete name Program reset </pre>
<p>Confirm with the ENTER key. The program is then deleted.</p> <p><i>Note: If the "Program delete" operation is carried out first, then the program name is also deleted.</i></p>		<pre> PARAMETERS Copy-Paste Pr: 001 ----- Pr: 002 HEAD </pre>

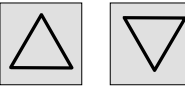
5. CHOICE OF THE PROGRAM TO BE RUN

Position the key in the ACCESS position.		
Starting from the main menu, place the cursor in front of the RUN PROG. function.		<pre>MAIN MENU ▶RUN PROG.: 001 PARAMETERS SPE CYCLE : Disabled</pre>
Confirm with the ENTER key.		<pre>MAIN MENU ▶RUN PROG.: 001 PARAMETERS SPE CYCLE : Disabled</pre>
Display the number of the program required by scrolling through the numbers with the navigation keys.		<pre>MAIN MENU RUN PROG. : 004 ◀ PARAMETERS SPE CYCLE : Disabled</pre>
Confirm your choice with the ENTER key.		<pre>MAIN MENU ▶RUN PROG. : 004 PARAMETERS SPE CYCLE : Disabled</pre>

6. STARTING A MEASUREMENT CYCLE

Press the START key to start a measurement cycle.		<pre>RUN/Pr: 004 PRESS =0.500 bar READY</pre>
The cycle phases appear on the display: wait, fill, stabilization, test, dump.		<pre>CYCLE/Pr: 004 PRESS =1.00 bar STABILIZATION</pre>

7. STOPPING A CYCLE

Press the RESET key to stop the measurement. The display “ READY ” indicates that the instrument is ready to perform a new measurement test.		<pre>RUN/Pr: 004 PRESS =0.500 bar READY</pre>
--	---	--

Chapter 4

FUNCTIONS OF THE INSTRUMENT

1. MENU STRUCTURE

1.1. MAIN MENU

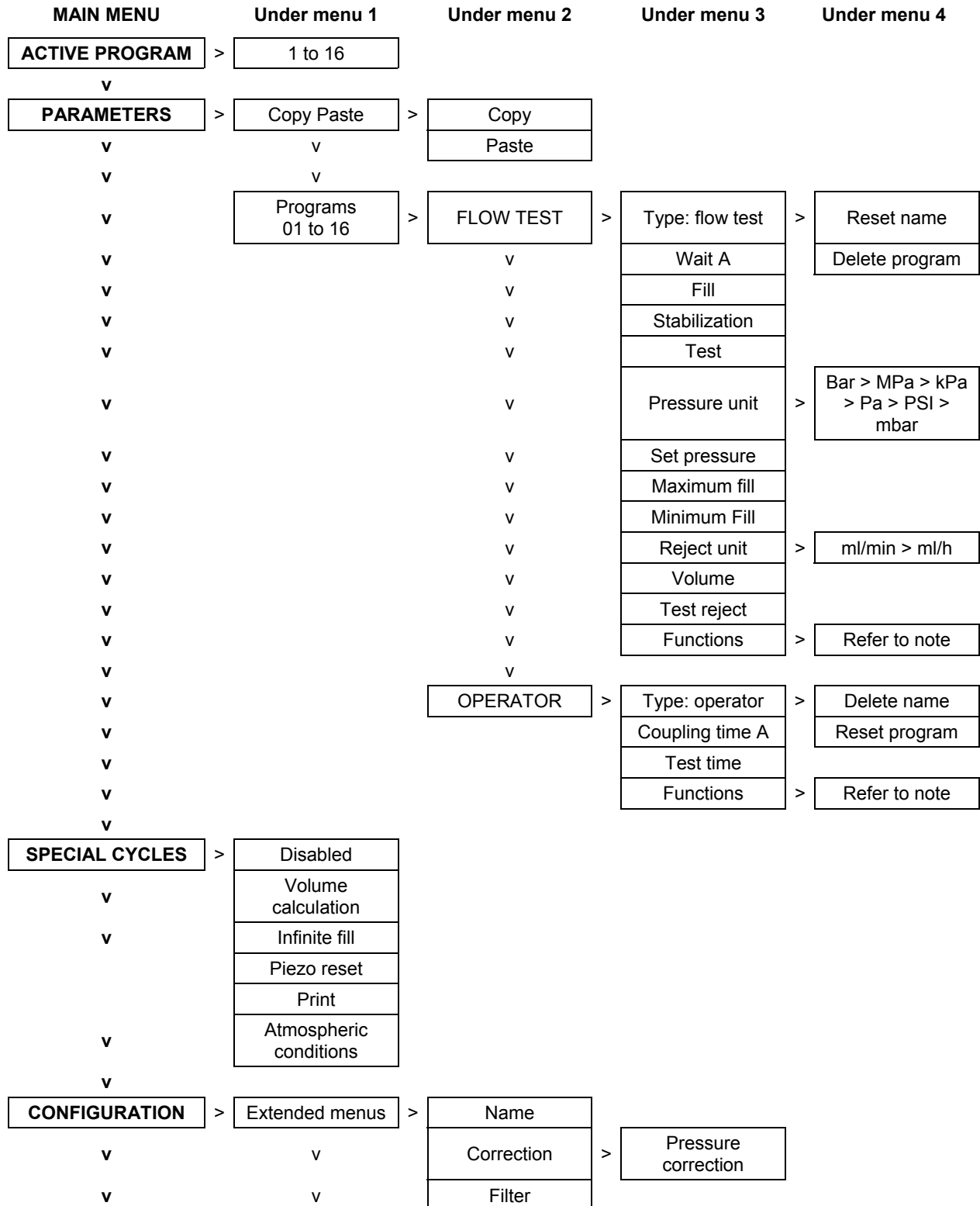

Chapter 4 – Functions of the instrument

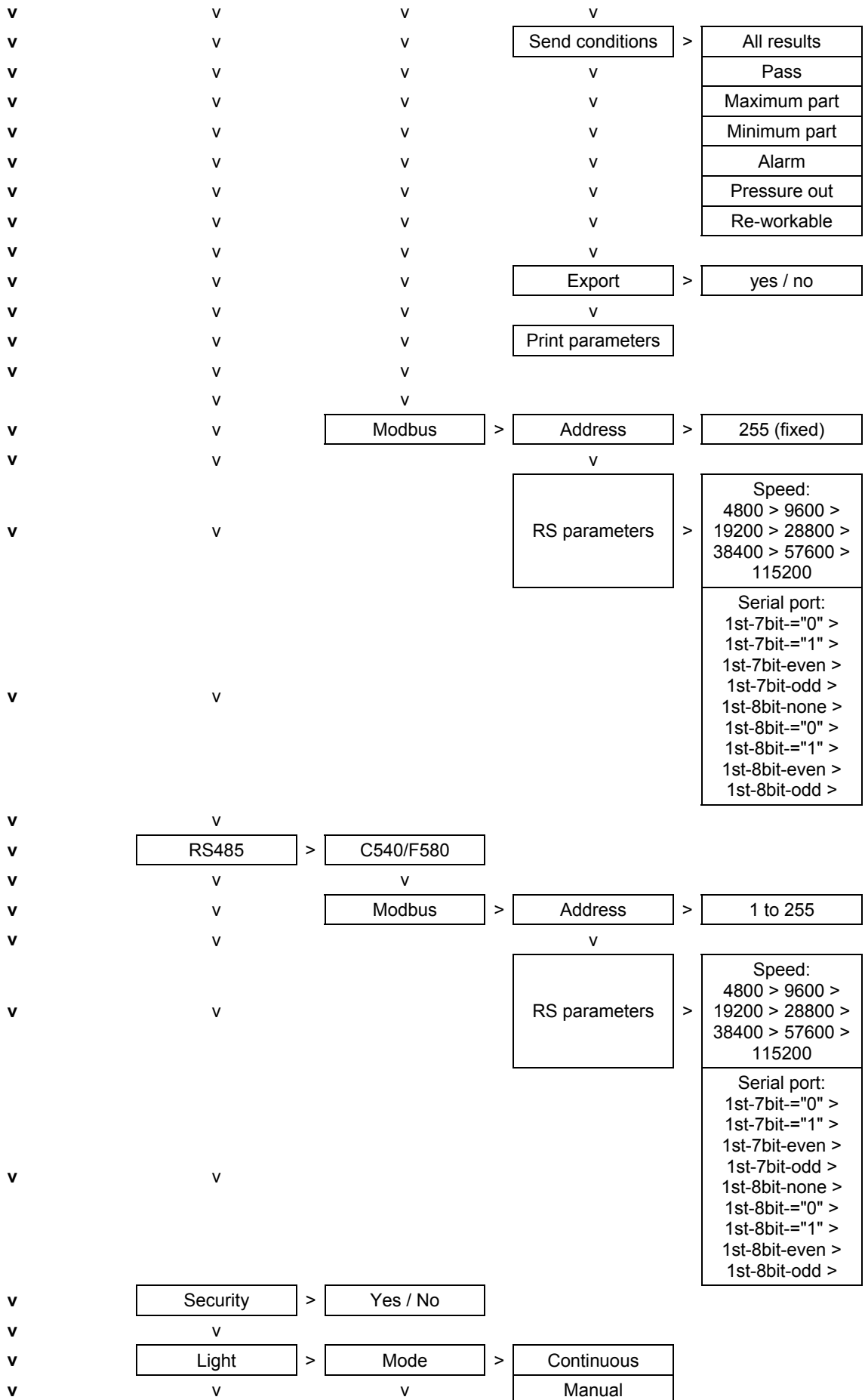

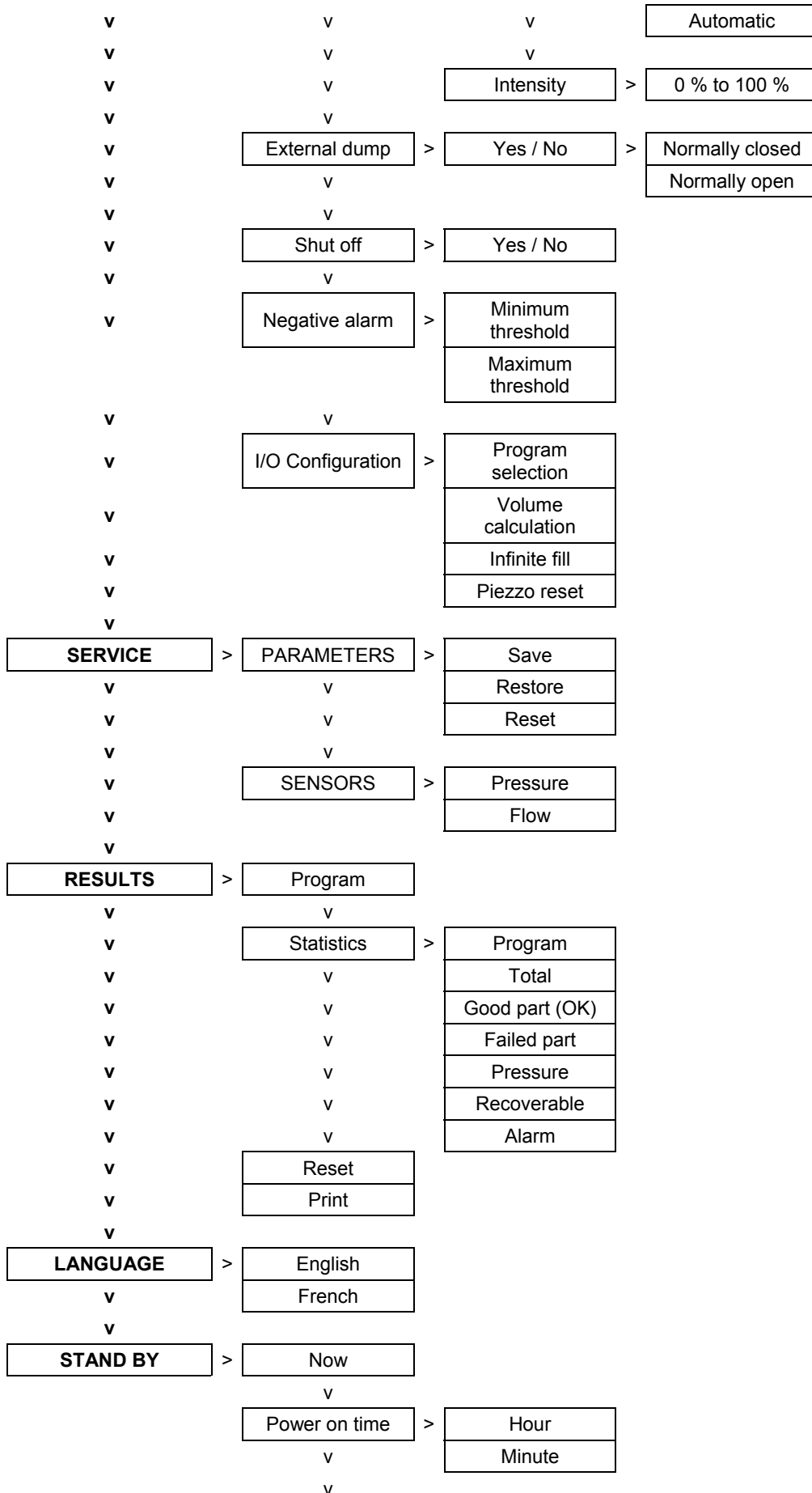

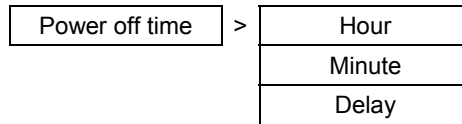

Note: The parameters that feature in the **EXTENDED MENUS** can be found in the **FUNCTIONS** menu of the program when they are activated (refer to the following chapter).

1.2. "FUNCTIONS" MENU WHEN ACTIVATED

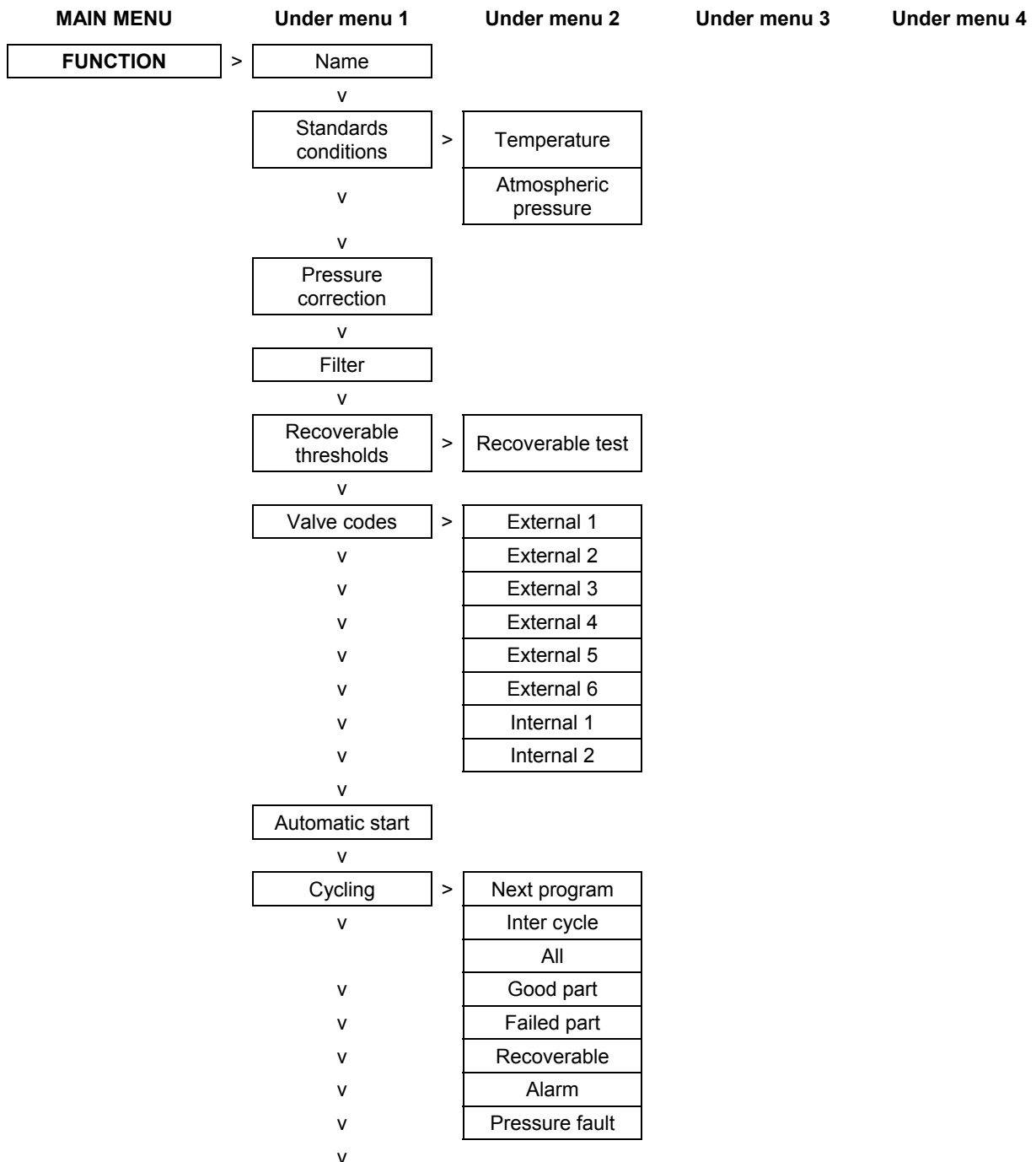

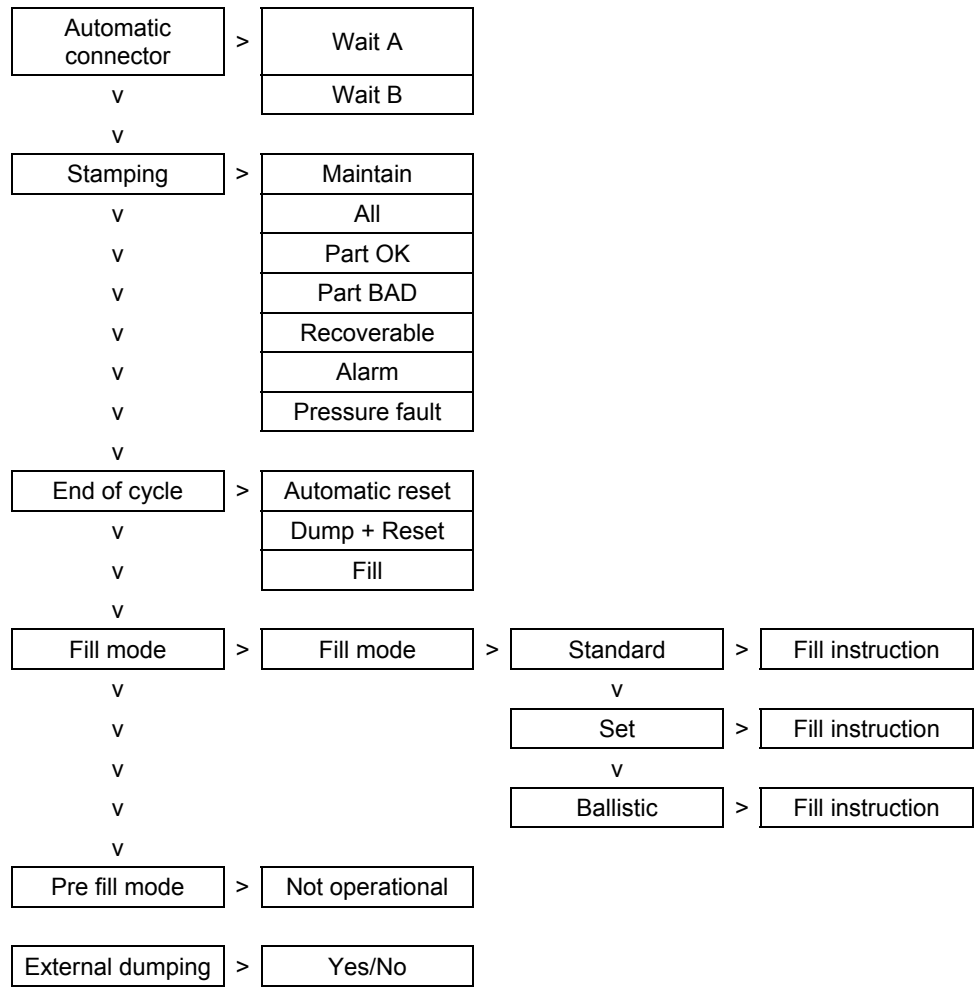









2. CONFIGURATION MENU

2.1. EXTENDED MENUS

The extended menus offer access to additional functions. If these functions are activated, they can be found in the **FUNCTION** menu when a program is created. If no additional functions are activated, the **FUNCTION** menu will be empty when a program is created.

2.1.1. Activation of the additional functions

<p>In the main menu, place the cursor in front of the CONFIGURATION label</p>		<pre> MAIN MENU SPE CYCLE : Disabled CONFIGURATION RESULTS </pre>
<p>Confirm using the ENTER key.</p>		<pre> CONFIGURATION EXTENDED MENUS PRINTER : YES HOUR </pre>
<p>Next, confirm the EXTENDED MENUS function with the ENTER key. The list of additional functions is then displayed.</p>		<pre> CONF I/EXTEND MENUS NAME : No CYCLING : No AUTO CONNECT : No </pre>
<p>To activate a function (e.g. the NAME function), confirm it with the ENTER key. Next, choose YES with the navigation keys and confirm again with the ENTER key. Start the operation again if you need to activate other functions.</p>	   	<pre> CONF I/EXTEND MENUS NAME : Yes CYCLING : No AUTO CONNECT : No </pre>
<p>Once all the chosen functions are activated, press the CANCEL key twice to return to the main menu.</p>	 	<pre> MAIN MENU SPE CYCLE : Disabled CONFIGURATION RESULTS </pre>

2.1.2. Setting the additional functions

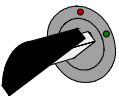
- ✓ Place the key in the **ACCESS** position .
- ✓ Create a new program (refer to chapter 3 §2 "Creation of a test program").
- ✓ In the parameters list for this new program, confirm the **FUNCTIONS** parameter (refer to chapter 3 § 2.3 "Parameter settings").

 **Only the functions which have been activated using the above method will appear in the FUNCTIONS parameter.**

2.1.3. List of additional functions

2.1.3. 1) Name

This function is used to customise a program, for example to name a program after the part to be tested.

 Select the option and enter settings if necessary.

2.1.3. 2) Standard conditions

The "Standard conditions" function allows bringing down the results measured by the instrument to define atmospheric conditions.

The measurement depends of the surrounding temperature and the surrounding atmospheric pressure. When this function is activated, the instrument calculates the flow results with regards to the parameters of atmospheric conditions captured. Like this the measurement results will take no notice of the surrounding variations.

To indicate the validation of this function, an asterisk is displayed after "**FLOW**".

 Select the option and enter settings if necessary.

2.1.3. 3) Pressure correction

The "pressure correction" function allows bringing down the measurement results by the instrument to a pressure condition defined in instruction.

When the function is activated, the instrument calculates the flow results with regards to the instruction pressure. Like this the results will take no notice of the pressure variations.

 Select the option and enter settings if necessary.

2.1.3. 4) Filtering

This parameter enables the modifying of the time constant for the display of the leak value during the test time.

It enables the filtering of extreme variations in flow if they exist.

The parameter is set in seconds, the longer the time set is, the greater the filtering (or dampening) and the slower the display of the variations in flow will be.

 Select the option and enter settings if necessary.

2.1.3. 5) Recovery limits

This option offers the option of two reject levels: non-tolerance level (the bad part is not recoverable) and recoverable reject level (the part is bad but may be reworked to become acceptable). This option is particularly used in casting, when parts are intended for treatment via impregnation.

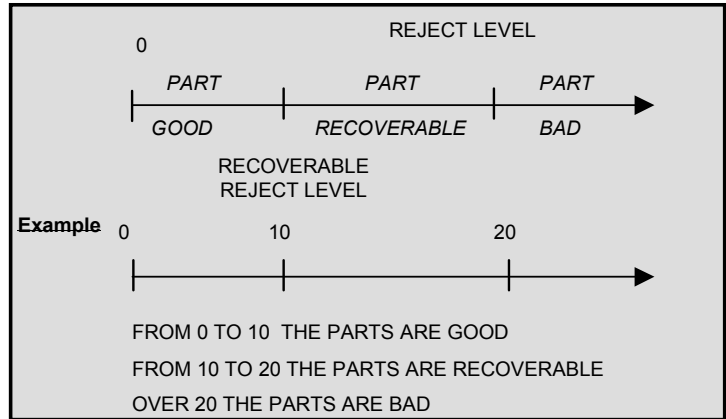

The associated parameter to be set is: RECUP Test.

For recoverable parts, with multi-head configuration on the central unit or on the heads themselves, the Pass (PB) and Fail (PM) outputs are both activated simultaneously. On the RS232 output, there is a message (DT) in the same way as there is for a bad part.

☞ Select the option and enter settings if necessary.

2.1.3. 6) Valve codes

The instrument has eight programmable electrical outputs (24V DC / 100 mA maximum) of which four may be reserved due to the presence of the stamping option (Valve code 1 internal and external) and external dumping (internal and external valve 2 code). These outputs (one or more) be attributed to program numbers. In general, they are used to select valves in sequence of cycles. The desired outputs may be activated for each program (Refer to chapter 1 paragraph 1.2.1.1)).

Associated parameters to be adjusted: External 1, External 2, External 3, External 4, External 5, External 6, Internal 1, Internal 2.

☞ Select the option and enter settings if necessary.

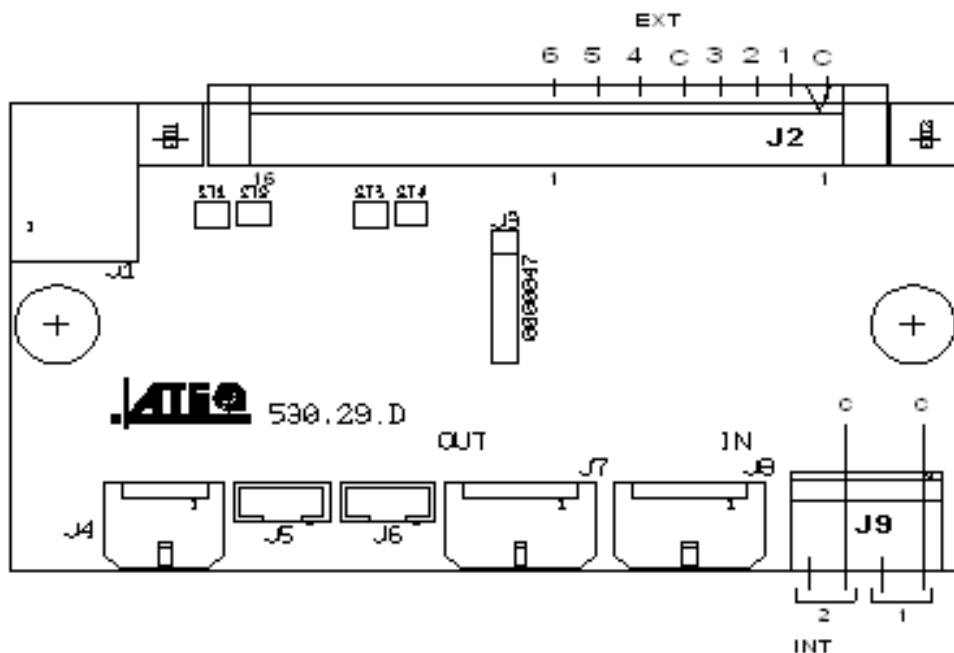





2.1.3. 7) Automatic start (Auto start)

The automatic start function allows the launching of a test cycle as soon as the part is connected to the test measurement, it therefore negates the need for the operator to press the start key. The part is detected due to a change in the flow in the measurement circuit.

The automatic start inhibits certain functions which are incompatible with the mode: automatic connector, stamping, external dump, cycle end, pre-fill, shut-off valve, chaining, double pressure and fill type.

The "test time" parameter disappears from the cycle parameters when the "auto start" function is applied.

 Select the option and enter settings if necessary.

<p>First of all, check or validate in the CONFIGURATION menu the START AUTO function.</p>		<pre>CONF1/EXTENDED MENUS VALVE CODES : Yes RECUP THRESH : Yes ▶AUTO START : Yes</pre>
<p>In the PARAMETERS /FUNCTIONS menu of the program, validate the AUTO START function.</p>		<pre>ARAM/Pr:001/FUNCTIONS VALVE CODES : No ▶AUTO START : Yes RECUP THRESH : Yes</pre>
<p>Return to the test cycle screen by pressing on the "C" several times.</p>		<pre>CYCLE/Pr: 001 PRESS = 150.0 mbar READY</pre>
<p>Press the "RESET" key to initialise the instrument. In this way, the instrument launches a reset cycle.</p>		<pre>CYCLE/Pr: 001 PRESS = 150.0 mbar AUTO ZERO</pre>
<p>Then, if no parts are connected to the measurement circuit, it will display a bar chart >>>>>>>>>>>> indicating the size of the leak.</p>		<pre>CYCLE/Pr: 001 PRESS = 150.0 mbar LEAK =>>>>>>>>>>>> LARGE LEAK</pre>
<p>If a part is connected to the test circuit, the leak decreases. The bar chart diminishes in the same proportions.</p>		<pre>CYCLE/Pr: 001 PRESS = 150.0 mbar LEAK =>> LARGE LEAK</pre>
<p>When the leak is virtually eliminated, the test cycle starts automatically.</p>		<pre>CYCLE/Pr: 001 PRESS = 150.0 mbar FILL</pre>

2.1.3. 8) Chaining

This function enables several tests to be carried out by the instrument one after the other.

The instrument offers the option of chaining according to 6 chaining criteria.

Associated parameters to be set: INTER-CYCLE (wait time between two cycles).

Chaining conditions: ALL (under all conditions), PART OK (part good), TEST FAULT (test part bad), WARNING, PRESS ERROR (pressure fault), RECUPERABLE (recoverable parts).

Note: *this function is not available in the "Automatic start" mode (Auto start).*

☞ Select the option and enter settings if necessary.

2.1.3. 9) Automatic connector

The automatic connector is a pneumatic control enabling the driving of an external logic (pneumatic sealing connector). This control is activated at the start of the cycle and is released at the end of the cycle (refer to "cycle end" diagram § 2.1.3.11)

If several programs are chained, the automatic connectors are activated according to the times set as parameters in the first program and are deactivated according to the times set as parameters in the last program in the chain.

They remain active throughout all cycles between the first and last program in the chain.

The various waiting times A are applied in the programs in between.

Associated parameters to be set: WAIT A, WAIT B.

Note: *this function is not valid in the "Automatic start" mode (Auto. start).*

☞ Select the option and enter settings if necessary.

2.1.3. 10) Stamping function

This option is used to activate a pneumatic output which marks the part (for example using a pneumatic cylinder).

Parameters can be set for the conditions and duration of marking.





This option requires two electrical outputs:

- ✓ an internal one for the internal cabling on the pneumatic output,
- ✓ an external one for "customer" cabling

One of the pneumatic outputs on the automatic connectors is used.

The output is activated at the end of test time for the programmed hold time.

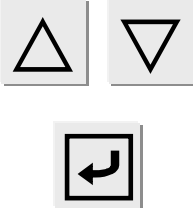
Use the following procedure to use the inking function.

<p>First, in the CONFIGURATION menu, confirm the STAMPING function.</p>		<pre> CONF/EXTENDED MENU REF. VOLUME : No VOLUME CALC. : No #STAMPING : Yes </pre>
<p>In the program's PARAMETERS/FUNCTIONS menu, confirm the STAMPING function.</p>		<pre> ARAM/Pr001/FONCTIONS #STAMPING : Yes </pre>
<p>Set the inking hold value (can be set between 0 and 650 seconds).</p>		<pre> Pr001/FUNCT/STAMPING #MAINTAIN : 00.5 s ALL : No OK : Yes </pre>
<p>Then select the inking conditions from those offered.</p>		<pre> Pr001/FUNCT/STAMPING MAINTAIN : 00.5 s ALL : No #OK : Yes </pre>

When the instrument is fitted with this option, the internal and external valve codes 1 are no longer available.

Note: this function is not valid in the "**Automatic start**" mode (Auto start).



 Select the option and enter settings if necessary.

2.1.3. 11) Cycle end

This function allows the selection of different cycle ends depending on the configuration of the instrument (connection to a PLC...).

a) Relay sequencing depending on the varying cycle ends

In the aim of networking the **ATEQ G520** with its environment (PLC, PC ...), the following timing charts supply the sequencing of the electrical outputs (relay boards on the J3 connector) and pneumatic outputs (automatic connectors), depending on the commands entered on the front facia or the J3 connector (START, RESET).

Legend	
A	Automatic connector wait time A
B	Automatic connector wait time B
P - F	Pre-fill time
F	Fill time
S	Stabilization time
#	Undetermined time which comes into play at the end of the programmed test time and activation of the  Reset key.
T	Test time
D	Dump time
START	Activation of the  key on the front facia or contact between pins 2 and 3 of the J3 connector
RESET	Activation of the  key on the front facia or contact between pins 1 and 2 of the J3 connector.
Automatic connector	Active (high level): the pneumatic output is active (air exiting) Inactive (low level): the pneumatic output is inactive (absence of air)
PG or PB	Good or Bad Part relay on the J3 connector
EoC	End of cycle relay on the J3 connector
t mini	Minimum take into account time on an input, 500 ms on the J8 connector of a central module and 50ms on the J3 connector of a measurement head.

 **The time scale is not respected, however the indications regarding time are correct.**

b) « Automatic RESET » cycle end (systematic reset)

If the part is OK, the Part OK relay will be activated as soon as the test ends and remain so until the start of the following cycle. Following the dump time, the end of cycle relay is activated (or after the wait time B if the value is not naught).

If the part is bad, the bad part relay is activated as soon as the test is completed. The instrument automatically dumps and sends a cycle end signal. A new cycle can then be launched.

Example with optional external pre-fill and dump:

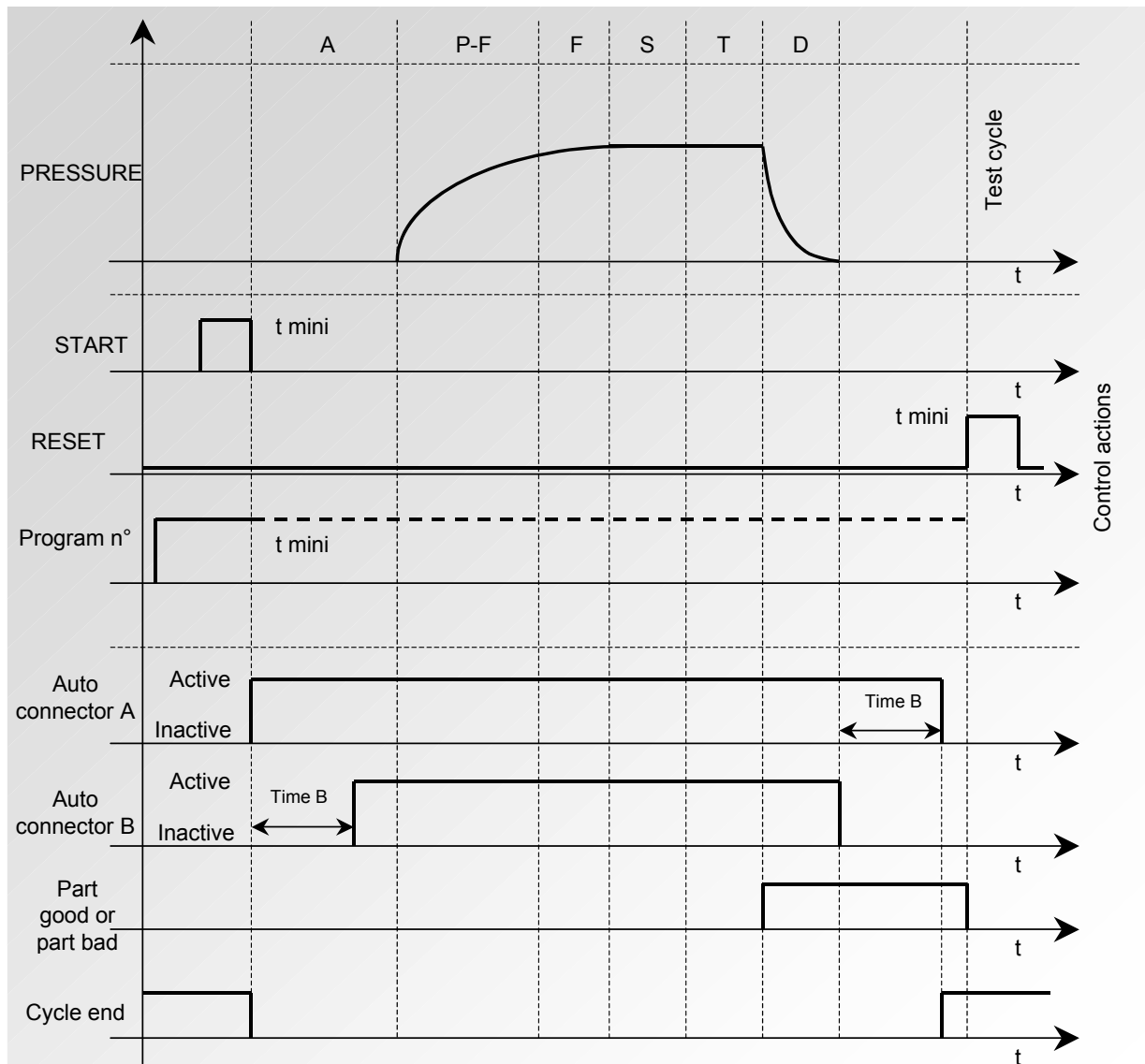

The active program is the one selected before starting up. It remains active even if the program inputs on the connector are no longer activated. This selection can only be modified during the inter cycle period.

To return to program 1, when a cycle is not in progress, press any of the program selection inputs.

**c) Ending a cycle with the RESET key (« Automatic RESET »
Cycle end)**

Example with optional external pre-fill and dump:

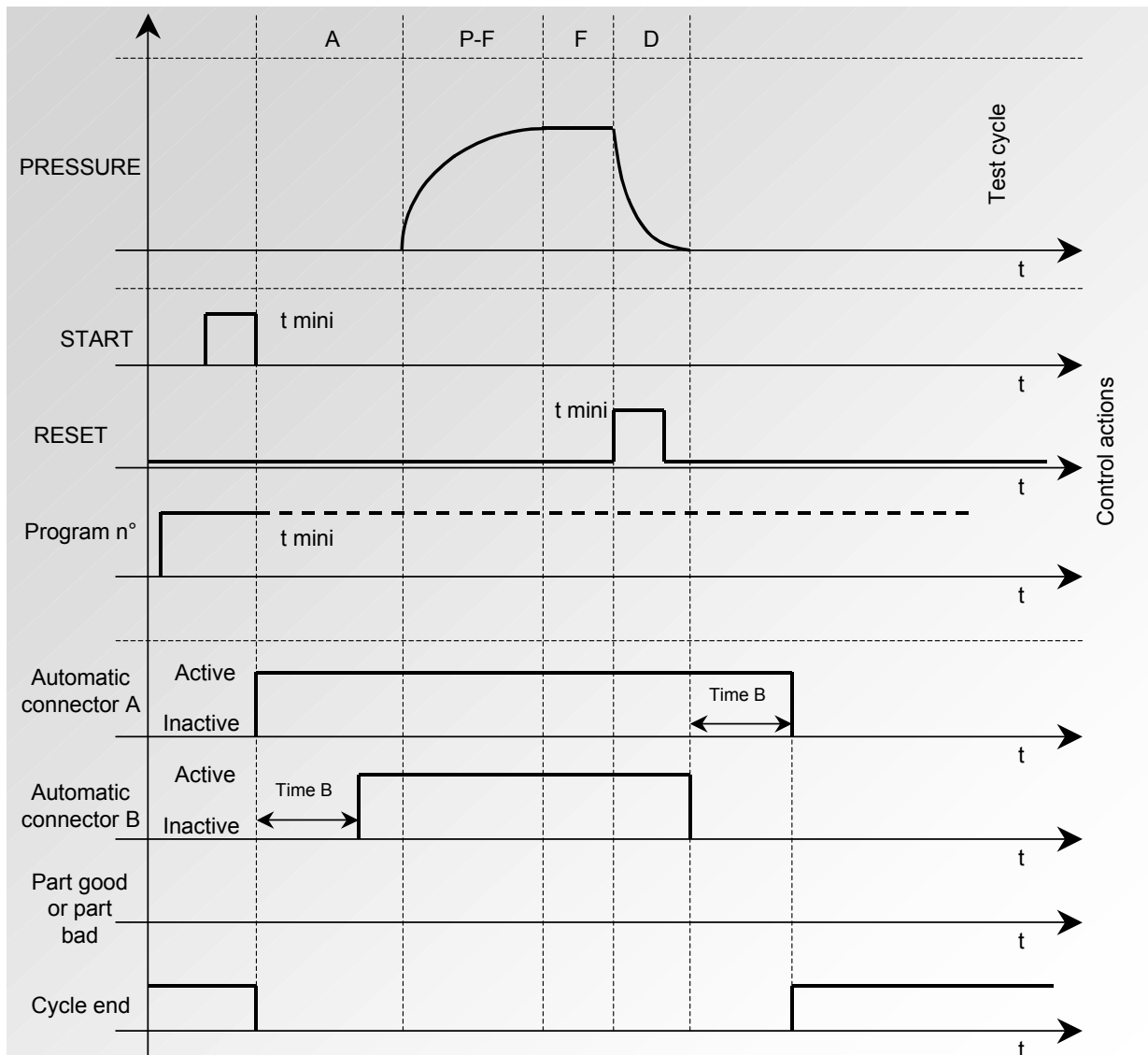

The active program is the one selected before starting up. It remains active even if the program inputs on the connector are no longer activated. This selection can only be modified during the inter cycle period.

To return to program 1, when a cycle is not in progress, press any of the program selection inputs.

d) « RESET + dump » cycle end (automatic dump)

If the part is OK, the part OK relay is activated as soon as the test time is finished, and remains so (only in position 2) until the next cycle is launched.

At the end of the dump time, the end of cycle relay is activated.

If the part is Bad, as soon as the test time is over, the bad part relay is activated and remains so until the end of the cycle. The dump is then carried out. The cycle can be

ended by pressing the **RESET**  key.

Example with optional external pre-fill and dump:

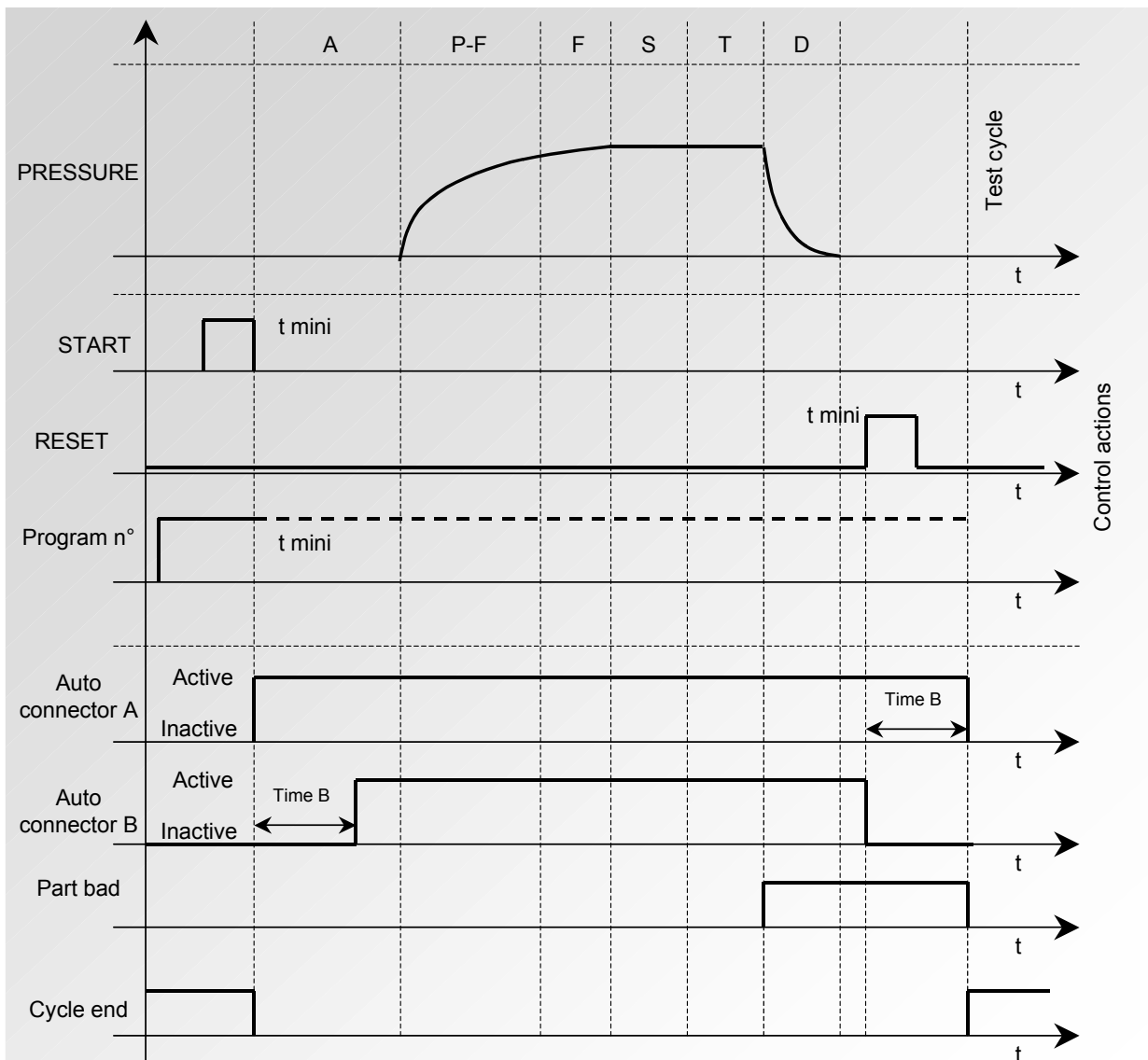

The active program is the one selected before starting up. It remains active even if the program inputs on the connector are no longer activated. This selection can only be modified during the inter cycle period.

To return to program 1, when a cycle is not in progress, press any of the program selection inputs.

e) « Fill » cycle end

If the part is OK, the good part relay is activated at the end of the test time and remains so till the start of the next cycle.

At the end of the dump time, the end of cycle relay is activated (or after the wait time B if the value is not naught).

If the part is bad, as soon as the test time is finished the relay becomes and remains activated.

The instrument waits for a reset from the operator or the PLC to start the dump time and send the end of cycle signal.

Example with optional external pre-fill and dump:

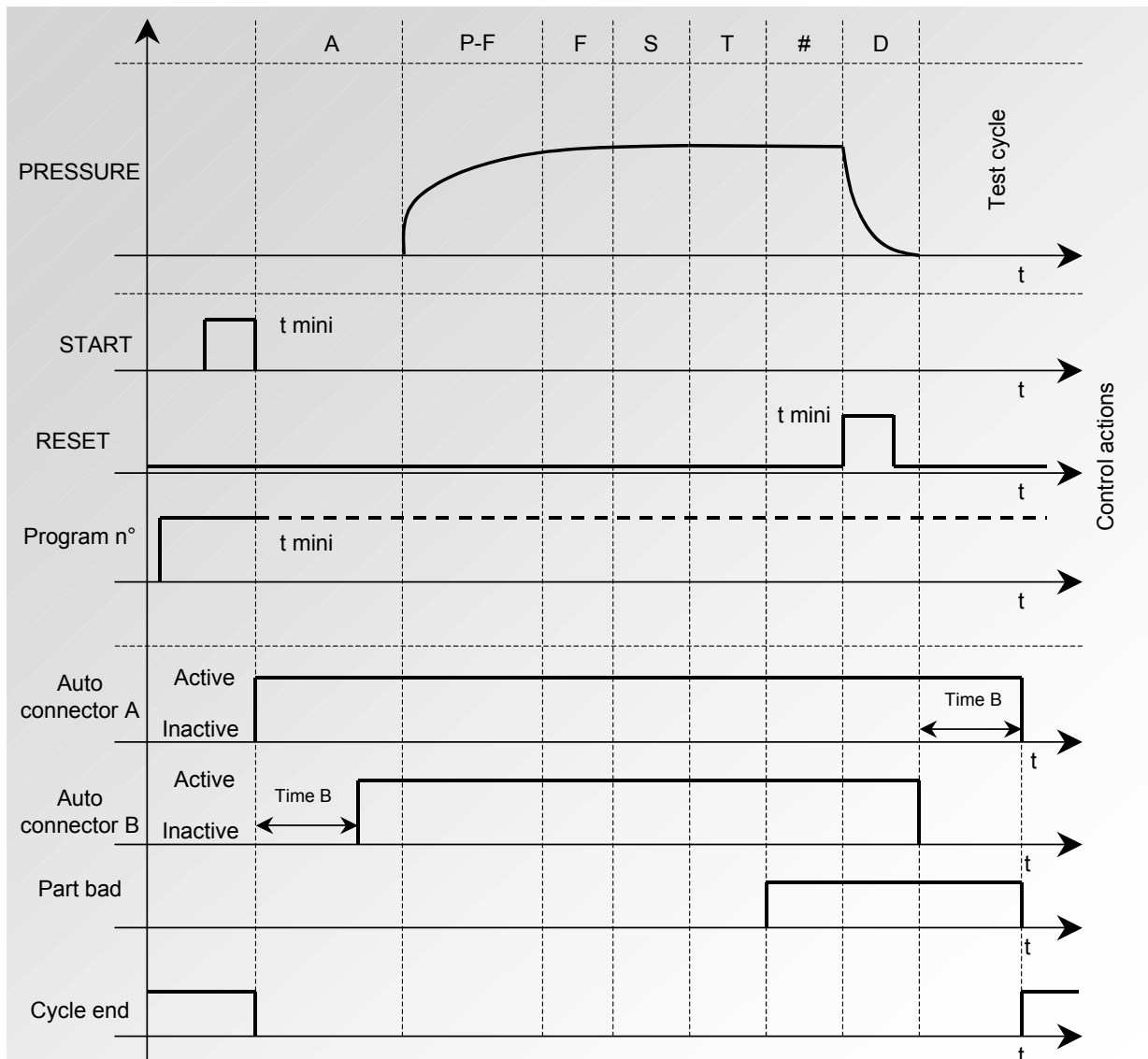

2.1.3. 12) Cycle timing chart with stamping and dumping

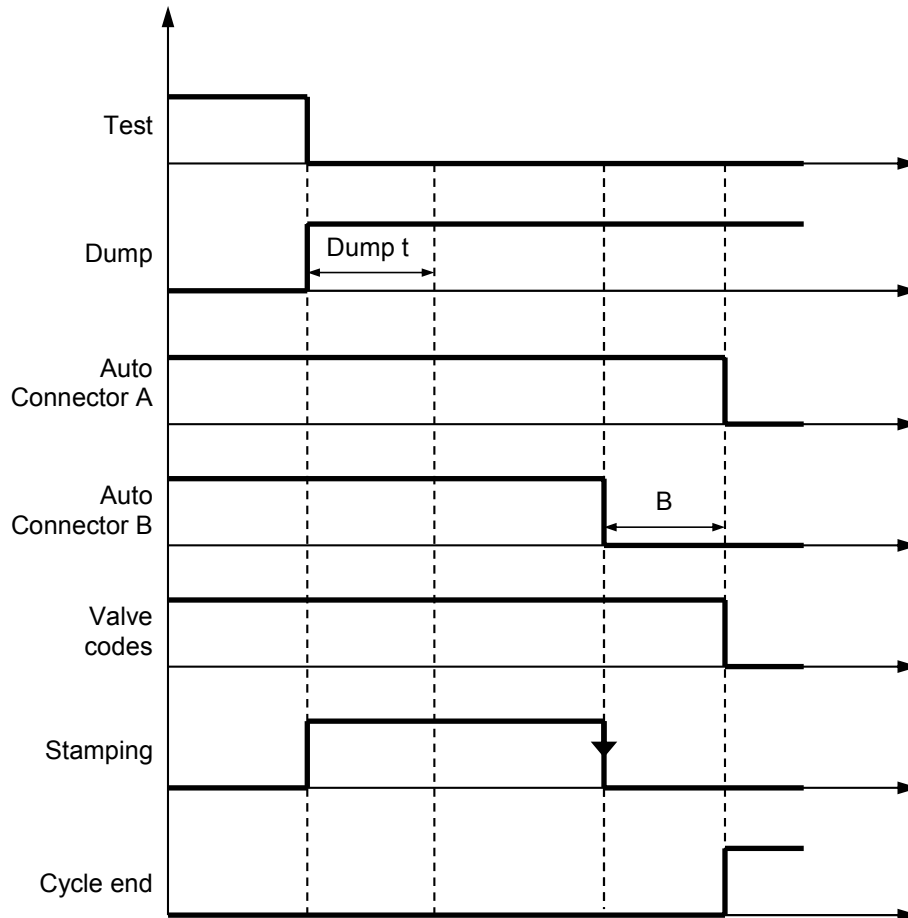

In the above example it's the stamping time superior than the dumping time who initiates the end of the cycle, otherwise the dumping time initiates the end of cycle.

2.1.3. 13) Fill mode

This function allows the choice of one of three possible types of fill.

Note: this function is not valid in the "Automatic start" mode (Auto start).

☞ Select the option and enter settings if necessary.

a) Standard

Carries out the fill time whilst monitoring the pressure thresholds..

b) Set

When the instructed pressure is reached, the filling is stopped and the instrument moves on to the next stage of the cycle.

c) Ballistic

This type of fill allows for a fluctuation of the air pressure (filling of parts with important deformations) and notably allows the overshooting of the maximum fill threshold without stopping the cycle and delivering an error message. Never the less, to switch to stabilization, the test pressure will have to be within the thresholds once the filling is complete.

2.1.3. 14) Type of Pre-fill

The type of pre-fill function is used to test large volume parts: to fill the part faster, allowing for a reduction in the cycle time. The regulator output is directly linked to the test output.

Insertion of the pre-fill time in the measurement cycle.

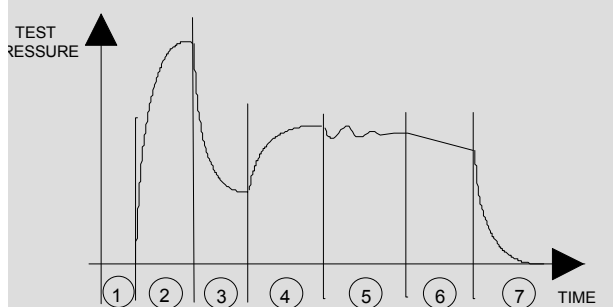

- 1) Wait,
- 2) Pre-fill,
- 3) Fill,
- 4) Stabilization,
- 5) Test,
- 6) Dump.

NB: this function is not valid in the "**Automatic start**" mode (Auto start).

☞ Select the option and enter settings if necessary.

a) *Standard*

Carries out the pre-fill in the programmed time.

b) *Set*

Not operational.

c) *Ballistic*

Not operational.

☞ Select the option and enter settings if necessary.

2.1.3. 15) Volume calculation

If a flow type unit is used, the parameter must be set for the total test volume. The "**Volume calculation**" function allows its determination and setting in the parameters

Preparation of the instrument

- ✓ Connect to the instrument a part with no leak.
- ✓ Connect a known standard leak to the rapid connector on the instrument's measurement circuit. .
- ✓ Adjust the test pressure of the calibration leak.
- ✓ Run a special "**Calc. vol.**" cycle by entering the value of the leak in the "**INSTRUCT.**" line.
- ✓ Carry out the special "Volume calculation" cycle. At the end, by pressing on the "Enter" key, the volume value will be displayed.
- ✓ The value of the volume is updated automatically within the active program.

2.2. AUTOMATIC SAVE

This function has for main objective to save the test parameters from the RAM memory of the instrument to its flash memory.

When this function is not validated, each time the key switch is turned from the **ACCESS** to the **LOCKED** mode, the instrument displays **NO PARAMETERS SAVED IN FLASH**. The save operation can be carried out manually in the **SERVICE PARAMETERS** menu.





When the **AUTOMATIC SAVE** function is confirmed with a **YES**, the parameters are saved automatically when the key is turned from the **ACCESS** to the **LOCKED** position.

This function is useful if the parameters in the RAM are accidentally erased. The instrument will then automatically read and restore the flash parameters in the RAM.

2.3. PIEZO AUTO ZERO

This function enables the setting of the frequency or of the number of measurement cycles between two Piezo auto zeros.

- **"Frequency" counter**: to set a time space between two auto zeros of 1 to 999 minutes. When the dial is on zero, no auto-zero is carried out.

<p>Confirm with Yes the PIEZO AUTO AZ in the Configuration menu.</p>	 	<pre>MAIN/CONFIGURATION REGUL. CTRL : Ext. ▶PIEZO AUTO AZ: Yes</pre>
<p>Then, enter the frequency parameter and/or number of cycles.</p>	 	<pre>/CONFI/PIEZO AUTO AZ ▶FREQUENCY : 05</pre>

☞ Select the option and enter settings if necessary.

2.4. BAR GRAPH

This function is able only with a RC5 remote control or if the instrument possesses a 14 characters L.E.D. display.

It allows having the flow value on a graphic display with a scale in regards of the captured reject thresholds.

On the inferior scale is the programmable reject threshold at 30, 50 or 70 % of the display.

On the superior scale is the current flow value.



Select the option and enter settings if necessary.

2.5. HOUR

This function includes a clock (hours, minutes) and an internal calendar (day, month, year).

Select the option and enter settings if necessary.

2.6. RS232

2.6.1. C540/580

This function enables the configuration of the instrument so that it may be supervised by an ATEQ central module.

Select the option and enter settings if necessary.

2.6.1. 1) Print frame

Not operational.

2.6.2. Printer

This function enables the configuration of the instrument to enable the printing of the program data (parameters) as well as the test results. When the option is activated (YES), each time a cycle is started, the test results are systematically printed.

Select the option and enter settings if necessary.

2.6.2. 1) RS parameters

These parameters enable the configuration of the instrument enabling it to communicate with the printer.

Associated parameters to be set: Speed, Stop byte, number of data bytes, parity.

Select the option and enter settings if necessary.

2.6.2. 2) Print frame

This function enables the configuration of the results printout.

Associated parameters to be set: PRESSURE (Display or not of the test pressure), Prog. name (Display of the program name when set), Date & Time (printing of the date and the time), Lines before (number of lines before the result), Lines after (number of lines after the result), Inter line (space between each line), Form feed (new page).

a) Frame format

The results frame is based on 40 columns.

• **Example for test OK result**

```

1 2 3 4 5 6 7 8 9 10 11 12 13 14 15 16 17 18 19 20 21 22 23 24 25 26 27 28 29 30 31 32 33 34 35 36 37 38 39 40
< 0 1 > :      9 7 . 9   m b a r : ( O K ) :      5 . 7   c m 3 / m n
    
```

Frame detail :

Columns	Characters
1	<
2-3	Figure indicating program number
4	>
5	:
6	space
7 – 11	Display of the test pressure
12	space
13 – 16	Pressure unit
17	:
18	(
19 – 20	2 letters indicating OK for good part TD for bad part
21)
22	:
23	space
24 – 27	Value of the leak measurement
28	space
29 > XX	2 to 6 letters indicating the unit

• **Example for a test result with time and date**

```

1 2 3 4 5 6 7 8 9 10 11 12 13 14 15 16 17 18 19 20 21 22 23 24 25 26 27 28 29 30 31 32 33 34 35 36 37 38 39 40
< 0 1 > : 3 0 / 0 5 / 2 0 0 2   1 0 : 4 1 : 1 6
< 0 1 > : 1 0 3 . 1   m b a r : ( O K ) : 3 . 2   c m 3 / m n
    
```

2.6.2. 4) Exporting

This function can be used to create and send a special results frame which can be processed by a PC using Microsoft Excel.

This frame is of the same type as the print parameters frame except that the different character strings follow each other and are separated by a punctuation mark which enables the various boxes to be entered automatically in Microsoft Excel.

This frame is operated by connecting a computer to the instrument's RS 232 link.

Columns detail:

- | | |
|---------------------------|-------------------------------|
| 1) Customization. | 6) Numeric value of pressure. |
| 2) Program number. | 7) Pressure unit. |
| 3) Test result message. | 8) Alarm message. |
| 4) Numeric value of test. | 9) Date. |
| 5) Test unit. | 10) Hour. |

Exportation example:

Flow mode:

1	2	3	4	5	6	7	8	9	10
NAME	1	(OK)	0.0	cm3/h	150.0	mbar		05/06/02	13:19:18
NAME	1	(OK)	45.8	cm3/h	149.4	mbar		05/06/02	13:20:33
NAME	1	(TD)			133.6	mbar	>> F.S. TEST	05/06/02	13:21:12
NAME	1	(TD)	68.9	cm3/h	139.1	mbar		05/06/02	13:21:23
NAME	1	(AL)			147.6	mbar	>> F.S. TEST	05/06/02	13:21:54
NAME	1	(AL)			149.8	mbar	>> F.S. REF.	05/06/02	13:22:06
NAME	1	(AL)			188.6	mbar	PRESS. EXCEED	05/06/02	13:25:41
NAME	1	(AL)			90.9	mbar	LOW PRESSURE	05/06/02	13:26:00
NAME	1	(AL)			0.0	mbar	P0	05/06/02	13:26:06
NAME	1	(AL)			152.6	mbar	SENSOR	05/06/02	13:28:02
NAME	1	(AL)					F.S. piezzo	05/06/02	13:30:30

Operator mode:

1	2	3	4	5	6	7	8	9	10
NAME	5	(OK)			152.2	mbar		05/06/02	13:34:50
NAME	5	(TD)			152.2	mbar		05/06/02	13:34:53

 Select the option and enter settings if necessary.

2.6.2. 5) Print parameters

When this option is confirmed the test parameters are printed immediately.

a) Example of parameter print frame

1	2	3	4	5	6	7	8	9	10	11	12	13	14	15	16	17	18	19	20	21	22	23	24	25	26	27	28	29	30	31	32	33	34	35	36	37	38	39	40
V	e	r	s	i	o	n		0	1	.	0	0	j																										
3	.	1	/	0	5	/	2	0	0	2																													
P	r		0	1																																			
T	Y	P	E		:		F	L	O	W		T	E	S	T																								
W	A	I	T		A		:		0	0	.	1		s																									
F	I	L	L		:		0	1	.	0		s																											
S	T	A	B		:		0	1	.	0		s																											
T	E	S	T		:		0	2	.	0		s																											
P	r	e	s	s	.	U	N	I	T		:	m	b	a	r																								
I	N	S	T	R	U	C	T		:		1	5	0	.	0																								
M	a	x		F	I	L	L		:		1	8	0	.	0																								
M	i	n		F	I	L	L		:		1	2	0	.	0																								
R		U	N	I	T		:		c	m	3	/	m	n																									
V	O	L	U	M	E		:		0	.	0	0	7		L																								
T	e	s	t		R	E	J	E	C	T	:		0	1	0																								

2.6.3. Modbus

This function enables the configuration of the Modbus link when the instrument is installed in this type of network. The address of the station is fixed at 255, the frame parameters and RS parameters (speed, serial port) must be entered. See the Modbus ATEQ specific manual

 Select the option and enter settings if necessary.

2.7. RS485

2.7.1. C540/580

This function allows configuring the RS485 output to a C540 or F580 central when the instrument is installed in a network.

☞ Select the option and enter settings if necessary.

2.7.2. Modbus

This function allows configuring a Modbus link when the instrument is in this kind of network. The station address, RS parameters (speed, serial port) are to be informed. See the specific ATEQ Modbus user manual.

☞ Select the option and enter settings if necessary.

2.8. SECURITY

This function deactivates the **START** and **RESET** keys on the instrument front panel. Programs can only be started from the instrument inputs (J3 connector).

☞ Select the option and enter settings if necessary.



2.9. LIGHTING THE SCREEN







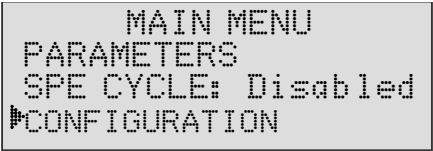

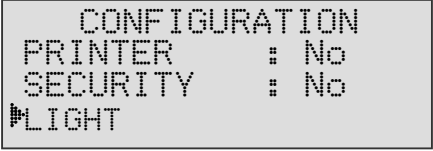

Screen illumination can be programmed and modified. The lighting can be adjusted according to the ambient conditions or the user's choice.

There are three lighting modes:

- ✓ **continuous** mode, display screen permanently lit whatever the conditions,
- ✓ **manual** mode, the screen remains lit for 20 minutes and if the keyboard has not been used by the end of this period the screen shuts down and only relights when the keyboard is touched again,
- ✓ **automatic** mode, which is identical to manual mode, with illumination of the screen also if an action is carried out from the external inputs (rear connectors).

Using these three modes, the lighting intensity of the screen can be programmed from 00 (screen off) to 07 (maximum lighting intensity).

<p>In the main menu, position the cursor by the CONFIGURATION menu then confirm by pressing ENTER.</p>		 <pre> MAIN MENU PARAMETERS SPE CYCLE: Disabled CONFIGURATION </pre>
<p>Move the cursor down until it is in front of the LIGHT menu then confirm by pressing ENTER.</p>		 <pre> CONFIGURATION PRINTER : No SECURITY : No LIGHT </pre>

Place the cursor in front of MODE to choose the required lighting mode and confirm using ENTER .	 	<pre>CONF/LIGHT MODE : CONTINO INTENSITY : 04</pre>
Select the lighting mode and confirm using ENTER .	 	<pre>CONF/LIGHT/MODE CONTINOUS MANUAL AUTO</pre>
To return to the previous menu, press the C button once		<pre>CONF/LIGHT MODE : PERMANEN INTENSITY : 07</pre>
To select the lighting intensity for the display, place the cursor in front of the INTENSITY menu and confirm using ENTER .	 	<pre>CONF/LIGHT MODE : CONTINO INTENSITY : 04</pre>
Then select the lighting intensity from 00 (off) to 07 (maximum luminosity) and the new lighting intensity will be applied as soon as ENTER is pressed.	  	<pre>CONF/LIGHT ODE : CONTINO INTENSITY : 06</pre>

2.10. EXTERNAL DUMP OPTION





This option can be used to control a dump valve outside the instrument (for example: a remote Y valve).



External dumping enables the part to be emptied before it is disconnected if the test pressure is too high.

This option requires two electrical outputs:

- ✓ an internal one for internal cabling the pneumatic output,
- ✓ an external one for "customer" cabling.

Use the following procedure to use the external dump function.

First, check or confirm the EXTERNAL DUMP function in the CONFIGURATION menu.	 	<pre>CONFIGURATION LIGHTING STAMPING : Yes EXT. DUMP : No</pre>
After confirming the function, select the mode for the dump valve, NORM. OPEN or NORM. CLOSED .	 	<pre>CONF/EXT. DUMP NORM. CLOSED NORM. OPEN</pre>

<p>Then in the PARAMETERS / FUNCTIONS menu, confirm the EXT. DUMP function and at each end of cycle the external dump output will be activated.</p>		<pre> ARAM/Pr001/FUNCTIONS BLOW MODE : No STAMPING : Yes EXT. DUMP : Yes </pre>
<p>Then, set the parameter the dump time (time during which the dump valve is open)</p>		<pre> M/Pr001/FUNCT/DUMP DUMP : 03.0 s </pre>

If the instrument is fitted with this option, internal and external valve codes 2 are no longer available.

2.11. SHUT OFF (OPTION)

The "Cut off" option when it's installed in the instrument and validate, allows to driving an external valve.

This external valve stops the air or gas flow when the instrument is out of cycle measurement.

This option needs two electrical outputs:

- ✓ one for the internal cabling of the pneumatic output,
- ✓ one external for the "customer" cabling.

For the bringing into service of the "Cut off" function follow the following procedure:

<p>Validate the function in the CONFIGURATION/CUT OFF menu.</p>		<pre> CONFIGURATION LIGHTING EXT. DUMP : No SHUT OFF : Yes </pre>
--	---	---

When the instrument possesses this function, the valves codes 2 internal and external are not available.

When this function is installed in the instrument, the "External dump" can't be installed.

2.12. NEGATIVE FLOW ALARM

A negative flow can be brought on by the instability of the part to be tested or by an internal leak of the instrument air chest side. More the volume to be tested is small, more the thresholds will be small and more the volumes are big and more the thresholds will be big (the measurement more difficult in this case).

The advised values are: maximum threshold at 30 % for volumes smaller than 150 cm³ and maximum threshold at 100 % for volumes bigger than 150 cm³. The percentage can be eventually being reduced to the minimum just before having the fault following the instability of the part to be tested.

In the event of negative flow, two reject thresholds are set (factory settings) these thresholds show the state of the negative flow on the display.

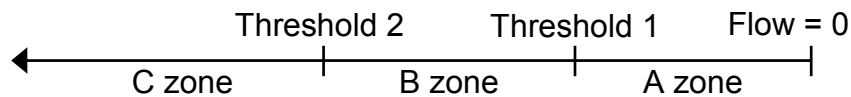

The thresholds mark three zones:

- ✓ **A zone:** 0 ml/h is displayed and the green indicator is permanently lit,
- ✓ **B zone:** 0 ml/h is displayed and the green indicator flashes,
- ✓ **C zone:** The "F. S. REF" alarm is displayed (the two red indicators are lit).

The thresholds set in the factory are 5 % and 30 % or 30 % and 100 % of the full scale (respectively for thresholds 1 and 2).

2.13. I/O CONFIGURATION

This menu is used to configure programmable input 7 on connector J3 on the 16-program input/output board.



See the chapter 1, paragraph 1.2.1.4) "J3 Connector (Inputs/Outputs) programmable input".

3. SPECIAL CYCLES MENU

3.1. SPECIAL CYCLES AVAILABLE

The following list shows all the special cycles which are possible: those available will vary depending on what is checked in the extended menus or according to the optional extras requested at the time of manufacture of the instrument.

Special cycle	Function
✓ Inactive	No special cycle selected.
✓ Volume calculation	Cycle which enables the calculation of the volume of the test circuit.
✓ Infinite fill:	Cycle used to put test part under pressure for infinite time.
✓ Piezo auto reset:	Cycle used to carry out forced reset of the piezo transducer and the electronic regulator.
✓ Print:	This cycle allows to send on the RS232 link the last results measured by the instrument.
✓ Atmospheric conditions:	This cycle allows displaying the atmospheric conditions measured by the instrument.





To run a special cycle, select it in the "special cycles" menu, then press the  button. To stop it, press the  button. In some cycles the stop is automatic.

3.2. VOLUME CALCULATION

This special cycle enables the calculation of the test circuit volume.

Preparation of the instrument





- ✓ Connect the instrument to a part with no leak.
- ✓ Connect a calibration leak on the rapid connector of the instruments test circuit.
- ✓ Adjust the test pressure of the calibration leak.
- ✓ Carry out the "**Volume calculation**" special cycle, setting the leak value in the "**INSTRUCTION**" line of the menu.
- ✓ Start the special volume calculation cycle. At the end of the cycle, by pressing on the "**ENTER**" key the value of the volume is displayed.
- ✓ In the active program, the value of the volume is automatically updated.

<p>In the main menu, place the cursor in front of SPE CYCLE and validate with the ENTER key.</p>		<pre> MAIN MENU ACTIVE PROG. : 001 PARAMETERS ▶ SPE CYCLE: Inactive </pre>
<p>Next, place the cursor in front of Volume Calcul. and validate with the ENTER key.</p>		<pre> SPE CYCLE Inactive ▶ VOLUME CALCUL. Piezo auto zero </pre>
<p>The display confirms that the special cycle is selected. Enter the value of the calibration leak in the INSTRUCT. line(calibration instruction), by using the navigation keys.</p>		<pre> CYCLE/VOL. CALC. INSTRUCT. : 0.54 INSTRUCT.P : 150.0 R. UNIT : cm3/mn </pre>
<p>Validate with the ENTER key.</p>		<pre> MAIN MENU ACTIVE PROG.: 001 PARAMETERS SPE CYCLE : Volume </pre>
<p>Press on the START key to launch the special cycle. At the end of the cycle, the calculated value of the volume of the part is sent directly in the active program menu to the VOLUME parameter.</p>		<pre> CYCLE/Pr : 001 PRESS = 150.0 mbar FLOW = 0.3 cm3/h TEST </pre>
<p>By pressing on the ENTER key, the calculated value of the volume is displayed.</p>		<pre> VOLUME ▶ VOLUME : 0.275 L </pre>

3.3. INFINITE FILL

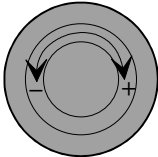

In presence of "shut-off" valve or external dump valve, it is possible to carry out an infinite fill with the instrument, in other words, a permanent flow of air at the test pressure in order to locate leaks (set-up adjustment...).

If the assembly allows it (risk of sudden disconnection of part under pressure) it is preferable, in the case of infinite fill, to have a dump time of zero so as not to draw in liquid if there is a leak (when looking for leaks using a soapy water based product).

<p>In the main menu, place the cursor in front of the SPE CYCLE function and confirm using the ENTER key.</p>		<pre> MAIN MENU CYCLE PROG. : 01 PARAMETERS SPE CYCLE: none </pre>
<p>Next, place the cursor in front of Infinite fill and confirm using the ENTER key.</p>		<pre> SPE CYCLE Regul. 1 adjust Regul. 2 adjust Infinite fill </pre>
<p>The display confirms that the special cycle has been selected.</p>		<pre> MAIN MENU RUN PROG. : 01 PARAMETERS SPE CYCLE: Inf fill </pre>
<p>Press the START key to start a new cycle.</p>		<pre> RUN/Pr : 001 PRESS = 355.5 mbar FILL </pre>
<p>In case of installation with a mechanical regulator, adjust the test pressure with the regulator.</p>		<pre> RUN/Pr : 001 PRESS = 1000 mbar FILL </pre>
<p>In case of installation with a electronic regulator, adjust the test pressure with the regulator by pressing the UP and DOWN arrows.</p>		<pre> RUN/Pr : 001 PRESS = 1000 mbar FILL </pre>
<p>To stop the cycle, press the RESET key.</p>		<pre> RUN/Pr : 001 PRESS = 1.00 bar READY </pre>

3.4. PIEZO AUTO ZERO

Used for compulsory reset to zero of the piezo sensor.

<p>In the main menu, place the cursor in front of SPE CYCLE and confirm using ENTER.</p>		<pre> MAIN MENU RUN PROG: 001 PARAMETERS ▶SPE CYCLE: Inactive </pre>
<p>Next, place the cursor in front of Piezo Reset function and confirm using ENTER.</p>		<pre> SPE CYCLE Pre-regul. adjust Infinite fill ▶Piezo reset </pre>
<p>The display confirms that the special cycle has been selected.</p>		<pre> MAIN MENU RUN PROG.: 001 PARAMETERS ▶SPE CYCLE: Piezo R. </pre>
<p>Press the START key to start the reset.</p>		<pre> RUN/Pr : 001 PRESS = 355.5 mbar RESET </pre>
<p>Once the reset is carried out, the cycle ends automatically.</p>		<pre> RUN/Pr : 001 PRESS = 355.5 mbar READY </pre>

Note: if the time between cycles is too long, the auto zero cycle may be programmed with a frequency in minutes, allowing the initialisation of the sensors in relation to the atmospheric pressure. Pressure is very important for the measurement of flow.



For automatic devices it may be necessary to inhibit the auto zero cycle.

<p>To inhibit the automatic zero cycle, go to the CONFIGURATION menu then confirm using non.</p>		<pre> CONFIGURATION EXTENDED MENUS ▶AZ PIEZO AUTO: No HOUR </pre>
--	---	---

Attention: If an auto zero cycle is not carried out regularly, measurement errors may occur and result in false readings for the air tightness of parts.



3.5. PRINT

This special cycle allows sending on the RS232 line the frame of the last measurement results.

<p>In the main menu, place the cursor in front of SPE CYCLE and confirm using ENTER.</p>		<pre> MAIN MENU RUN PROG: 001 PARAMETERS ▶SPE CYCLE: Inactive </pre>
<p>Next, place the cursor in front of Print function and confirm using ENTER. The frame is instantly send on the RS232 line.</p>		<pre> SPE CYCLE Infinite fill Piezo reset ▶Print </pre>

3.6. ATMOSPHERICS CONDITIONS

This cycle allows displaying the atmospheric conditions measured by the instrument. These atmospheric conditions are: atmospheric pressure and ambient temperature of the tested gas.

<p>In the main menu, place the cursor in front of SPE CYCLE and confirm using ENTER.</p>		<pre> MAIN MENU RUN PROG: 001 PARAMETERS ▶SPE CYCLE: Inactive </pre>
<p>Next, place the cursor in front of Atm conditions function and confirm using ENTER.</p>		<pre> CYCLE SPE Piezo reset Print ▶Atm. Conditions </pre>
<p>The instrument displays the atmospheric pressure and the measured temperature.</p>		<pre> ATM. CONDITION ATM PRES.: 1004 hPa TEMPERATURE : 30.0C </pre>
<p>To stop the cycle, press the RESET key.</p>		<pre> RUN/Pr : 001 PRESS = 1.00 bar READY </pre>

4. SERVICE MENU



4.1. PARAMETERS SERVICE

This menu is used to manage the memory containing the test cycle parameters.

- ✓ Save maintenance parameters menu: used to save the configuration of the parameters in the current test.
- ✓ Restore maintenance parameters menu: used to restore a previously saved configuration.
- ✓ Erase maintenance parameters menu: used to delete the current configuration.

To access the menu, turn the switch to the **ACCESS** position.

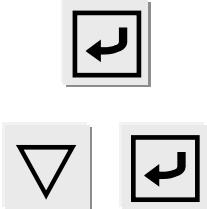

<p>In the main menu, place the cursor in front of SERVICE and confirm using ENTER.</p>		<pre> MAIN MENU CYCLE SPE: Disabled CONFIGURATION MAINTENANCE </pre>
<p>Then place the cursor in front of PARAMETERS and confirm using ENTER.</p>		<pre> MAIN/SERVICE PARAMETERS </pre>
<p>Then place the cursor in front of the action required :</p> <p>SAVE: save current parameters,</p> <p>RESTORE: replace current parameters by those stored in the memory,</p> <p>ERASE: delete current parameters and return to the initial configuration.</p> <p>and confirm using ENTER.</p>		<pre> IN/SERVI/PARAMETER SAVE : No RESTORE : No RESET : No </pre>
<p>To activate an operation, confirm using ENTER. Then choose YES using the arrows then confirm again using ENTER.</p>		<pre> IN/SERVI/PARAMETERS SAVE : Yes RESTORE : No RESET : No </pre>

Turn the switch to the **LOCK** position.

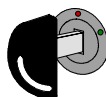

Note: if the parameters have been modified, then current and saved parameters are therefore different, when the instrument begins to operate, the following message is displayed on the screen.

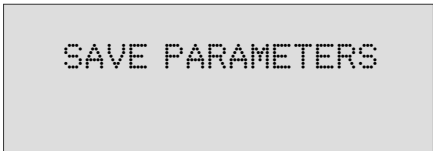



This message is not blocked and will disappear after a few seconds. It informs that a saving of the parameters may be necessary. In this case three solutions arise:

- 1) **Restore** the saved parameters (current parameters will be lost).
- 2) **Save** the current parameters in the memory (the parameters already in the memory will be lost).
- 3) **Do nothing** and work with the current parameters.

4.2. SERVICING OF THE SENSORS

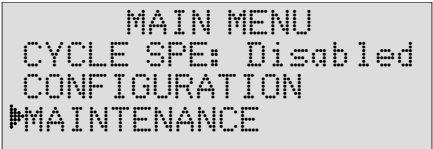
This menu allows the monitoring of the information that is communicated by the pressure sensors, "**PRESSURE**" for the absolute pressure piezo sensor and "**LEAK**" for the differential pressure sensor.

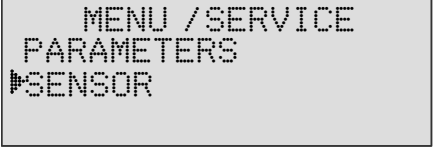
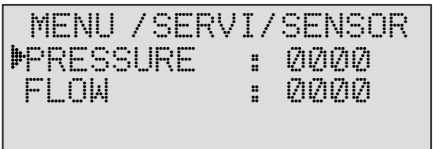
<p>In the main menu, place the cursor in front of the SERVICE heading and confirm with the ENTER key.</p>		
<p>Next, place the cursor in front of SENSORS and confirm with the ENTER key.</p>		
<p>The screen displays the values measured by the pressure sensors.</p>		

Note: without air pressure, the number of "PRESSURE" points must be less than 100, for a nil flow, the number of "FLOW" points must be less than 200.

5. RESULTS MENU

This function is used for:

- ✓ the detailed display of the test results: number of parts tested, number of good parts, number of bad reference parts, number of bad parts, number of recovered parts, number of times the alarm is triggered (each indicator is expressed as a % value),
- ✓ resetting the results memory,
- ✓ printing the results (number of good parts, number of bad parts).

6. LANGUAGE MENU



This function allows the choosing of the instrument language. Several languages are available. Two are installed at the fabrication of the instrument, the English is the language by default the other is chosen by the customer.

7. STAND BY MENU

This function is used to switch off the instrument without disconnecting it. Standby can be immediate or programmed with start and stop times.

There are two ways to achieve immediate standby:

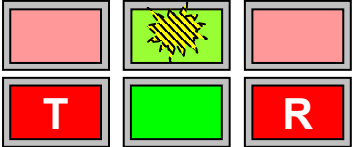













- 1) Either through the standby menu,
- 2) Or by pressing the **RESET**  button for more than three seconds.

<p>Note: when the instrument is on standby, the display is off and only the yellow indicator light flashes approximately every 3 seconds.</p>		
<p>To reactivate the instrument, simply press any key on the front panel or activate any input.</p>		

 Select the option and enter settings if necessary.

7.1. STANDBY USING THE MENU

Standby using the menu enables start and stop times for the instrument to be programmed.

<p>In the main menu, position the cursor beside STANDBY and confirm by pressing ENTER.</p>	 	<pre> MAIN MENU RESULTS LANGUAGE : English STAND-BY </pre>
<p>To program automatic standby at a given time, position the cursor beside STOP TIME.</p>	 	<pre> STAND-BY Now : No Pow-on time : No STAND-BY : No </pre>
<p>Confirm the STOP TIME parameter using YES</p>	 	<pre> STAND-BY Now : No Pow-on time : No Pow-off time : Yes 4 </pre>
<p>Then set parameters for the time (hours and minutes) when the standby must take effect. "TIME DELAY" is the delay (in minutes) between the programmed time and actual standby</p>	 	<pre> STAND/Pow-off time HOUR : 00 MINUTE : 00 Delay : 00 </pre>
<p>To program the start-up time for the instrument, position the cursor beside START TIME</p>	 	<pre> STAND-BY Now : No STAND-BY : Yes Pow-on time : Yes Pow-off time : Yes </pre>
<p>Confirm the START TIME parameter using YES</p>	 	<pre> STAND-BY Now : No STAND-BY : Yes 4 Pow-on time : Yes Pow-off time : Yes </pre>
<p>Then set parameters for the instrument start time (in hours and minutes).</p>	 	<pre> STAND/Pow-on time HOUR : 00 4 MINUTE : 00 </pre>

Chapter 5

ACCESSORIES

1. ACCESSORIES SUPPLIED WITH THE INSTRUMENT

1.1. POWER SUPPLY

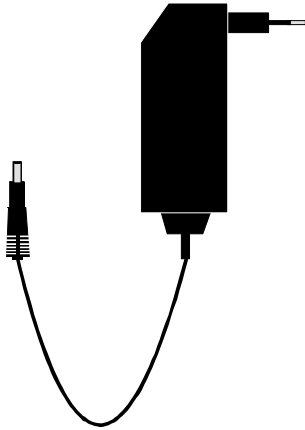

The power supply of the **G520** converts a network voltage (120 to 240 V AC) into a 24 V DC low voltage supply. It has no power switch and works as soon as it is plugged in. It is protected against surges and short circuits via a thermal fuse (Do not use any other type of fuse).

2. OPTIONAL ACCESSORIES

2.1. CALIBRATED LEAK

Calibrated leaks are used to check the instrument's calibration.

PRESSURE	Master leak type										
	A	B	5	C	D	50	E	F	G	1000	5000
2 kPa (20 mbar)			1,5	3,12	6,6	18	31,2	1,24	2,05	4,2	53
5 kPa (50 mbar)		2,3	4	7,4	17,5	42	1,3	2,6	5,25	11,3	132
15 kPa (150 mbar)	2,82	6,7	12	23	55	2,2	4	8,2	17	35,5	338
30 kPa (300 mbar)	4,8	12	24	46,8	2,12	3,6	7,6	22,4	40	74,5	700
50 kPa (500 mbar)	10	25	48	1,4	3,5	8	15,5	31	63	150	1142
100 kPa (1 bar)	23	56	1,8	3,3	8	19	37	74	149	360	2230
200 kPa (2 bar)	55	2,3	4,6	8,5	21	47	89	194	380	830	4343
400 kPa (4 bar)	2,5	6,6	12,1	23,3	56	125	220	540	1030	1500	8750
1 MPa (10 bar)	11,5	29	50	95	198	420	705	2310	3700	4450	

 **kPa.cm³/h**
(bar.cm³/h)

 **kPa.cm³/min**
(bar.cm³/min)

Note: the values indicated above are given for information and can vary by +/- 20%. The true rate is precisely measured before delivery with an accuracy of +/- 5% up to 1Mpa.cm³/min (10 bar.cm³/min) and +/- 3% from this value. **Special master leaks can be manufactured on request, within 5% of the requested value.**

- ✓ The calibrated leaks must be used with clean dry air.
- ✓ These leaks must not be dipped in water. It is essential that they are stored in their case after usage.
- ✓ The leaks must be checked periodically by the company's metrology department or by **ATEQ's** metrology service.
- ✓ Check that there is an O-ring seal and that it is in good condition.
- ✓ The instrument zero check must be done by replacing the leak with a sealing connector and not by sealing off the leak itself.
- ✓ To check that the leak has not been blocked, attach a piece of flexible tubing to the leak and submerge its extremity in water to watch for bubbles. Only with pressure regulation and not vacuum.

2.2. NEEDLE VALVE AND LEAK/FLOW CALIBRATOR (CDF)

2.2.1. Needle valve

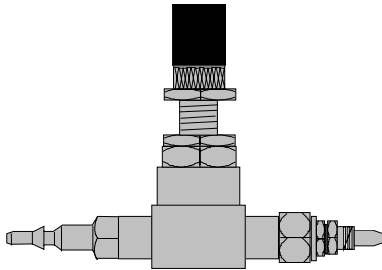

Needle valves are used to calibrate the leakage limits. These valves have an adjustable leak and depending on the model allow adjustments of between a few cm^3/h to several l/min .

These valves can be easily disturbed and therefore require the frequent use of some means of checking the setting (ex : **ATEQ** Leak/flow calibrator).

Note: it is strongly recommended that you do NOT leave a needle valve permanently connected on a leak detection machine with automatic calibration every « n cycles ».

2.2.2. CDF (Leak/flow Calibrator)

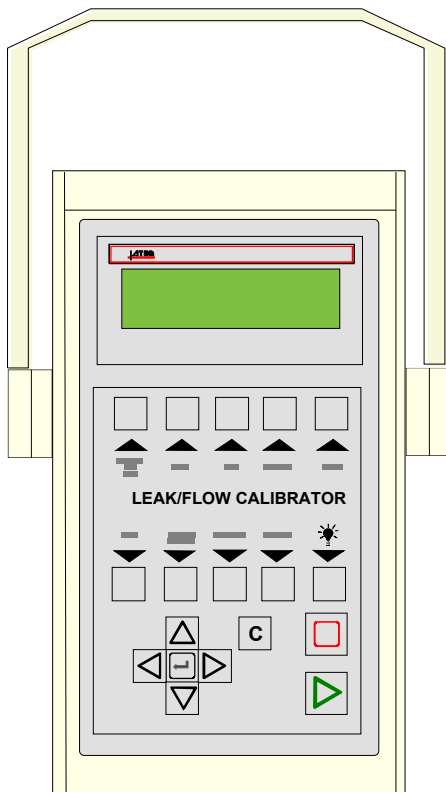

The **Leak/Flow calibrator** is a multiple range **ATEQ** flow meter intended for checking leak testing equipment and particularly **ATEQ** instruments. It measures a loss of charge with a differential sensor, which is connected to a calibrated flow tube.

2.3. AUTOMATIC CONNECTORS WITH EXPANDABLE JOINTS

ATEQ automatic connectors are used so that accurate and reliable assemblies can be built to check air tightness. They simplify the work of the operator as they are self-locking thanks to the use of a pneumatic valve supplied from the mains compressed air supply. Several connectors may be controlled by the same remote, powered by an **ATEQ** or another logic.

They adapt easily to a large number of fittings and apertures of varied dimensions. Their use ensures that non-machined walls can be guaranteed airtight.

There are four basic versions of **ATEQ** automatic connectors :

- ✓ SA for external connections,
- ✓ Si for internal connections,
- ✓ SAG and SIG for threaded and tapped connections.

They are either in anodised aluminium or stainless steel as standard. Different types of joints are available depending on the elasticity required.

2.3.1. Operation

The connector is positioned manually or automatically using a jack or cylinder.

Compressed air is allowed through the control aperture via a three part valve. The pressure pushes the cylinder which squashes the connector. The air tightness is therefore perfect and there will be no leakage in the connector seals.

2.3.2. Standard dimensions

SAG and SIG have been designed for threaded and tapped caps. For the time being, they are available in gas norm. Sizes, which are: 1/2", 3/4", 1", 1 1/4", 1 1/2", 2", BSP.

The SA and SI are designed for smooth nozzles, with dimensions from 3 to 80 mm for the external diameters (SA), and from 10 to 75 mm for the internal diameters (SI).

2.4. FILTRATION KIT

Clean, dry air must be used to ensure the reliability of the instruments.

The filtration kit is connected to the air input on the rear panel of the instrument.

It consists of a dust filtering cartridge (5µm) and another cartridge (0.01 µm) giving residual oil pollution equal to 0.01 ppm.

2.5. SIMPLE REMOTE CONTROL

The remote control allows control and selection of various settings remotely for instruments in the **ATEQ** range.

2.5.1. Casing reset/start

Example :
START / RESET.

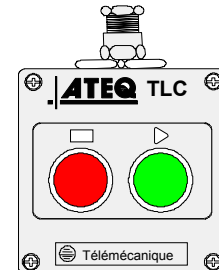

2.5.2. S5 four-function remote control

This remote control has four functions which can be used to control a series 5 instrument remotely. (F580 or C540 single head only).

The four functions on this remote control are as follows:

- ✓ RESET and start cycle.
- ✓ Increase or decrease program numbers.
- ✓ Display the number of the program selected.
- ✓ Display the test result, green indicator light for Pass, red indicator light for Fail or alarm.

Note 1: a program number can only be changed (increase or decrease) when no test cycle is running.

Note 2: this remote control does not function in the "Automatic start" mode.

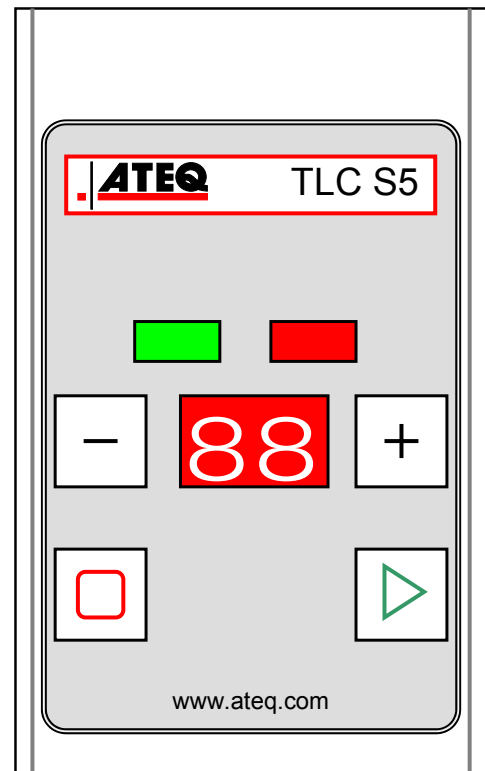

2.5.2. 1) Connection diagram

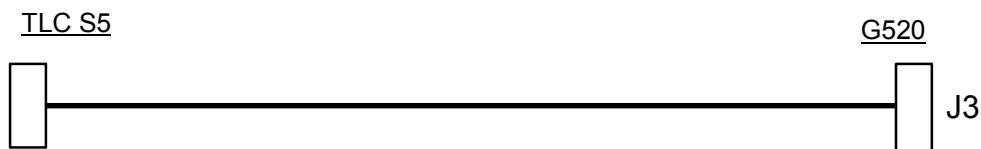

2.6. EXTERNAL SHUT OFF VALVE OPTION

This option allows avoiding blowing air or gas permanently on the test output.

The "Automatic start" mode becomes incompatible.

There's the choice between an electrical or a pneumatic order according to the option presents in the instrument:

- Electrical piloting 24 V DC by the output code number 2 with the "shut off" option activated in the **CONFIGURATION** Menu.
- Pneumatic piloting (6 bar network) with the A and B automatic connectors option. The shut off function must be activated in the **CONFIGURATION** menu.

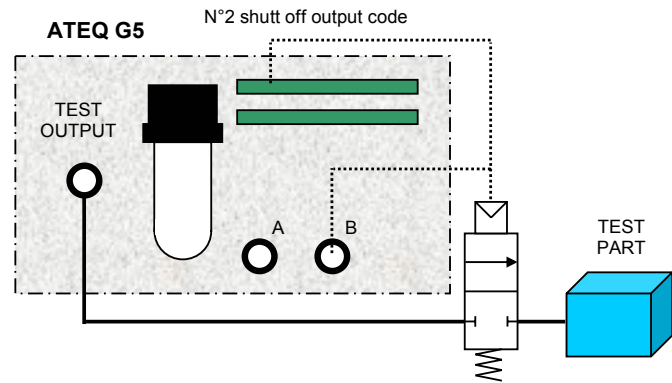

2.7. EXTERNAL DUMP VALVE AND SHUT OFF FUNCTION

This assembly allows dumping the test part out of test cycle and not blowing permanently air or gas. The "External dump" option must be imperiously present in the instrument.

Use a 3/2 Y valve (ATEQ standard) who will be preferably close to the part to be tested.

The "Automatic start" mode is being incompatible.

The "External dump" function must be activated in the **CONFIGURATION** menu, choose the valve type, normally closed or normally opened and then activate the "External dump" function in the programs functions.

There's the choice between an electrical or a pneumatic order according to the option presents in the instrument:



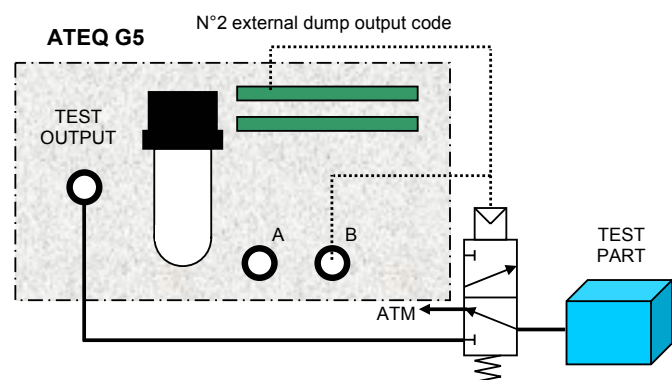

- Electrical piloting 24 V DC by the output code number 2 with the "External dump" option activated in the **CONFIGURATION** Menu.
- Pneumatic piloting (6 bar network) with the A and B automatic connectors option. The "External dump" function must be activated in the **CONFIGURATION** menu.



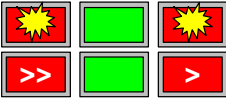

Chapter 6

ERROR MESSAGES

The **ATEQ G520** can display error messages if there are operational problems.

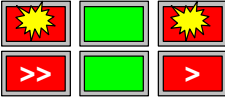
PROBLEM	LIT INDICATORS	MESSAGE DISPLAYED
<p>Test error. Flow in excess of the full scale. Action: check the test circuit.</p>		<pre>CYCLE/Pr001 PRESS=0.942 bar FLOW=>> F. S TEST READY (NO OK)</pre>
<p>Pressure in excess of the full scale. Negative flow. Action: check the test time, the part must not change in temperature. Refer to chapter 4 paragraph 2.12 “Negative flow alarm”.</p>		<pre>CYCLE/Pr001 PRESS= 150.0 mbar FLOW = >> F. S. REF. READY (AL)</pre>
<p>Pressure in excess of the max. threshold of the pressure sensor. Action: reduce the pressure with the mechanical thumb wheel.</p>		<pre>CYCLE/Pr001 PRESS = > F. SCALE RESET WAIT</pre>
<p>Default on the differential sensor. Action: contact the ATEQ After-sales service for a repair (probable presence of oil or water in the test circuit of the instrument).</p>		<pre>CYCLE/Pr001 PRESS= 150.0 mbar FLOW= SENSOR DEF. READY (AL)</pre>
<p>Pressure in excess of the max. threshold. Action: check regulator settings, and pressure limit .</p>		<pre>CYCLE/Pr001 PRESS= 140.0 mbar PRESS= > MAX READY (AL)</pre>
<p>Pressure below the min. threshold. Action: check the network pressure, regulator settings and the pressure limits.</p>		<pre>CYCLE/Pr001 PRESS= 30.0 mbar PRESS= < MIN READY (AL)</pre>

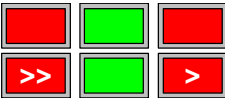
PROBLEM	LIT INDICATORS	MESSAGE DISPLAYED
<p>No Pressure Action: check the connection to air supply network and check the regulator adjustment.</p>		<pre>CYCLE/Pr001 PRESS= 0.0 mbar PRESS= NIL PRESSURE READY (AL)</pre>
<p>PROG error: the I/O's have selected a program with no parameters. Action: enter program parameters.</p>		<pre>CYCLE/Pr.:009 ERROR</pre>
<p>Inappropriate size for the selected unit of pressure. Action: change unit or modify the minimum and maximum pressure limits if these and the test pressure can be used with this unit.</p>		<pre>PARAM/Pr001 >Press. Unity: mbar MAX Fill : FPPP MIN Fill : 0.0</pre>

Chapter 7

OPERATIONAL PROBLEMS

1. PHENOMENON NOTED

If a test machine begins to detect too many bad parts (statistically, more than three consecutively), it is advisable to carry out a **check on the whole unit**. The quality of the manufacture and operation of the leak detector should be the last things considered.

1.1. CONDITION OF THE MACHINE'S SEALS

This is the no.1 defect as the seals are subject to high levels of dirt contamination (alumina, shavings). Regular cleaning of the seals is an effective remedy.

1.2. DAMAGED INSTRUMENT SEALS

There is a possibility that the seals may be cut by shavings or worn by repetitive squashing. This can be prevented by regular servicing and replacement of the seals.

1.3. BUMPER PAD

This is a defect which may occur after a certain amount of time as the bumper pads may be worn, or if the pressure settings in the air cylinder are inadvertently disturbed. Check the stability of the measurement and that the bumper pads are correctly installed.

1.4. PNEUMATIC AIR SUPPLY TOO LOW

This anomaly can cause false measurements (large leaks or erratic measurements). The air supply to the cells must be higher than the minimum of 4 bar and it is essential that it is greater than the minimum test pressure of 1 bar. Also check that sealing connectors are being used correctly.

1.5. PNEUMATIC LINK

The link and reference pipes will age and break with time. The pipes and seals must conform to the required quality. **ATEQ** recommends the use of RILSAN PA11 pipes and AVS type joints.

1.6. ENVIRONMENT

A measurement may be affected by a variation in background temperature (sun, draughts, storage of parts outdoors, handling of the test part by the operator, ...).

The dampness of parts may cause errors in the readings (insufficient drying after washing, outdoor storage, condensation, presence of water in the fixture, ...).

1.7. CALIBRATION

ATEQ does not accept any liability in regard to calibrations and settings to its instruments which are not carried out by its own staff.

1.8. CONCERNS ABOUT RELIABILITY OF THE INSTRUMENT'S CIRCUITS

If all the other checks do not resolve the problem, the instrument's circuit may be checked.

Proceed as follows:

- ✓ Segregate the instrument from its environment (pneumatic assembly),
- ✓ Connect up the instrument (test output),
- ✓ Choose an unused program,
- ✓ Set the parameters as follows :
 - ⇒ the regulator to the test pressure,
 - ⇒ the pressure monitoring thresholds to +/- 20 % of the test pressure,
 - ⇒ wait times A and B 0 seconds,
 - ⇒ fill time 2 seconds,
 - ⇒ stabilization time 2 seconds,
 - ⇒ test time 2 seconds,
 - ⇒ reject level 2,
 - ⇒ unit cm³/h,
 - ⇒ function all functions cancelled except "pressure correction".

Run two consecutive cycles.

The post test time result should not exceed 2 cm³/h.

Appendices

ATEQ G520

1. TECHNICAL CHARACTERISTICS OF THE G520

	G520
Dimensions H x L x D (mm):	136 x 250 x 255
Dimensions with air filter and regulator (mm):	136 x 250 x 370
Power supply:	24 VDC / 1,6 A Min 23,5 V ; Max 28 V
Pneumatic connections:	2,7/4, 3/5 or 4/6
Weight (kg):	about 4
Format:	½ 19 inches
Temperatures:	
Operational:	+10°C to +45°C
Storage:	0°C to +60 °C

2. MECHANICAL DEFINITION DRAWINGS OF G520

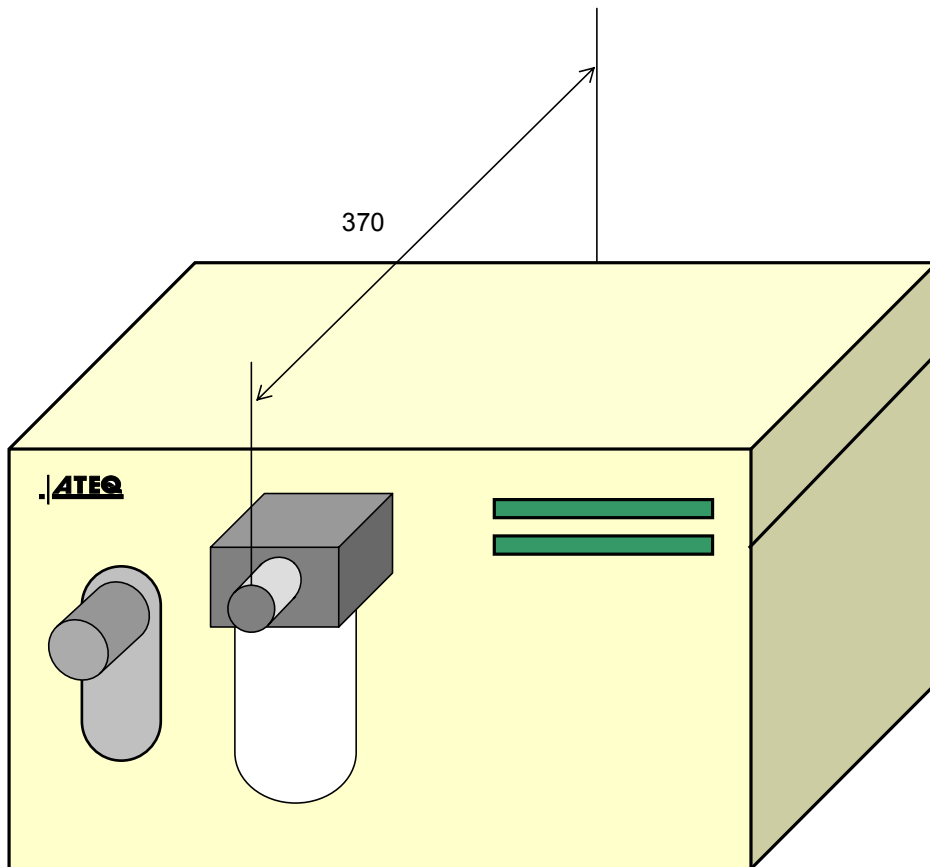
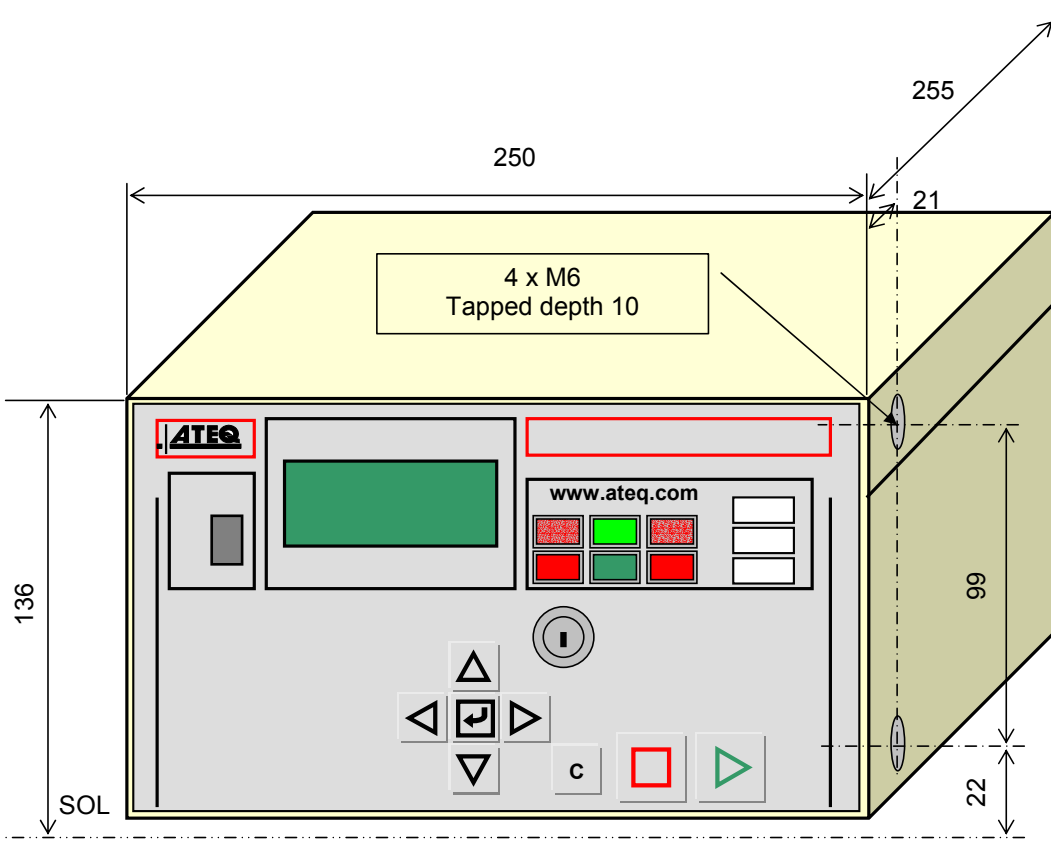

3. CONVERSION TABLE

		TO									
		Pa	kPa	bar	mbar	mmH2O	atm	Torr	psi	inH2O	inHg
FROM	Pa	1	10 ⁻³	10 ⁻⁵	10 ⁻²	0.10197	9.8692 10 ⁻⁶	7.5 10 ⁻³	1.45 10 ⁻⁴	4.01 10 ⁻³	2.95 10 ⁻⁴
	kPa	10 ³	1	10 ⁻²	10	101.97	9.8692 10 ⁻³	7.5	0.145	4.01	0.295
	bar	10 ⁵	10 ²	1	10 ³	10197	0.98692	750	14.5	401.46	29.53
	mbar	10 ²	10 ⁻¹	10 ⁻³	1	10.197	9.8692 10 ⁻⁴	0.75	1.45 10 ⁻²	0.401	2.95 10 ⁻²
	mmH2O	9.806	9.8067 10 ⁻³	9.8067 10 ⁻⁵	9.8067 10 ⁻²	1	9.6784 10 ⁻⁵	7.3556 10 ⁻²	1.4223 10 ³	3.937 10 ⁻²	2.895 10 ⁻³
	atm	1.013 10 ⁵	101.33	1.0133	1013.3	10332	1	760	14.695	406.78	29.921
	Torr	133.32	0.13332	1.3332 10 ⁻³	1.3332	13.595	1.3158 10 ⁻³	1	1.9337 10 ⁻²	0.535	3.937 10 ⁻²
	psi	6897.8	6.8948	6.8948 10 ⁻²	68.948	703.07	6.8045 10 ⁻²	51.71	1	27.68	2.036
	inH2O	249.09	0.2491	2.4909 10 ⁻³	2.4909	25.400	2.4583 10 ⁻³	1.8683	3.61 10 ⁻²	1	7.35 10 ⁻²
	inHg	3386.4	3.3864	3.3864 10 ⁻²	33.864	345.32	3.3421 10 ⁻²	25.4	0.491	13.595	1

4. PARAMETERS STORED

PARAMETERS		Program n°	Program n°	Program n°	Program n°	
T I M E	Waiting					
	Rise					
	Stabilization					
	Drop					
R E J E C T S	Test reject					
	Reference reject					
	Recovery test reject					
	Recovery reference reject					
	Rejection unit					
	Start pressure					
	Stabilization pressure					
	End pressure					
P R E S S U R E S	Maximum Stabilization pressure					
	Minimum threshold pressure					
	Minimum rise flow pressure					
	Maximum drop flow pressure					
	Minimum Stabilization flow pressure					
	Maximum Stabilization flow pressure					
	Minimum drop flow pressure					
	Maximum drop flow pressure					
	Pressure unit					
	F L O W S	Minimum rise flow				
		Rise flow				
		Stabilization flow				
Maximum drop flow						

5. VALVES CODES USED IN YOUR APPLICATION

PROGRAM GROUP:

PROGRAM	VALVE CODE	FUNCTION
01		
02		
03		
04		
05		
06		
07		
08		
09		
10		
11		
12		
13		
14		
15		
16		

Index

A		Modbus.....	57, 58
Access position key.....	21	N	
Additional functions.....	39	Navigation keys.....	20
Automatic connectors.....	43, 74	Needle valves.....	73
Automatic save.....	52	Negative flow.....	61
Automatic start.....	42	O	
Auto-zero frequency.....	52	Operational characteristics.....	7
B		Operational problems.....	79
Bar graph.....	53	Operator mode.....	24
C		P	
C540 / F580.....	53	Parameter settings.....	25
Calibration leaks.....	72	Part BAD indicator.....	22
Clock.....	53	Part OK indicator.....	22
Conversion table.....	83	Part volume calculation.....	63
Create a new program.....	23	Pneumatic connectors.....	17
Cycle end.....	45	Pneumatic supply.....	18
Cycle keys.....	20	Power supply.....	71
Cycle several test cycles.....	43	Pression (zero).....	78
D		Pressure correction.....	40
Deactivating the start key.....	58	Pressure inferior to min threshold.....	77
Delete a program.....	31	Pressure over max threshold.....	77
Determine the fill time.....	26	Pressure too high.....	77
Determine the stabilization time.....	27	Pressure units.....	27
Dimensions.....	82	Print.....	66
Duplicate a program.....	30	Print frame.....	54
E		Print frame formats.....	54
Electrical connectors.....	12	Print parameters.....	53
Error indicator.....	22	Print the results.....	53
Export results to MS Excel.....	56	Printer.....	16, 53
Extended menus.....	39	Printing the results.....	69
External dump.....	59, 76	Program choice.....	32
F		Program name.....	40
Fill instruction.....	28	Programmable input.....	15
Filtration kit.....	74	R	
Flow mode.....	24	Recoverable reject level.....	41
Functions menu.....	29, 37	Recoverable thresholds.....	41
I		Reject unit.....	28
I/O Configuration.....	61	Remote control.....	16, 75
Infinite fill.....	64	Remote control (S5).....	75
Infra-red link.....	21	Reset (automatic).....	65
L		Results memory reset.....	69
Language.....	69	RS232.....	16
Large leak indicator.....	22	RS485.....	58
LCD 4 line display.....	21	S	
Leak/Flow calibrator.....	73	Security.....	58
Lighting the screen.....	58	Sending conditions.....	55
Locked position key.....	21	Sensor default.....	77
M		Sensor servicing.....	68
Maximum fill.....	28	Service menu.....	67
Measurements characteristics.....	6	Service parameters.....	80
Minimum fill.....	28	Set pressure.....	28

Shut off	60	Test output.....	17
Shut off valve.....	76	Test reject.....	29
Smoothing	40	Test results display (detailed)	69
Stabilization time	27	Test time	27
Stamping	44	Type of pre-fill	51
Stand by	69		V
Standard conditions.....	40	Valve codes	41
Stop the measurement	32	Volume	29
Symbols.....	8	Volume calculation.....	51
	T		W
Technical characteristics	81	Wait times A and B	26
Test error	77		

